

# Operator's manual

Tracked excavator

# EZ25



<b>Machine model</b>	<b>E30-02</b>
<b>Edition</b>	<b>1.0</b>
<b>Document order number</b>	<b>1000488864</b>
<b>Language</b>	<b>en</b>



**WACKER  
NEUSON**

Documentation	Language	Order no.
Operator's manual	en	1000488864

Legend	
Original Operator's Manual	x
Translation of original Operator's Manual	–
Issue	1.0
Date	12/2021
Document	OM EZ25 en*

Copyright © 2021 Wacker Neuson Linz GmbH, Hörsching

Printed in China

All rights reserved, in particular the copyright, the right of reproduction and the right of distribution applicable worldwide.

This document may be used by the receiver only for the designated purpose. It may in no way be duplicated or translated in any other language, in whole or in part, without prior permission in writing from the manufacturer.

No reproduction or translation of this publication, in whole or in part, without the written consent from Wacker Neuson Linz GmbH.

Violations of legal regulations, in particular of the copyright protection, will be subject to civil and criminal prosecution.

Wacker Neuson Linz GmbH keep abreast of the latest technical developments and constantly improve their products. For this reason, we may from time to time need to make changes to figures and descriptions in this documentation that do not reflect the products that have already been delivered and which will not be implemented in these vehicles.

Technical data, dimensions and weights are only given as an indication. Non-metric values are rounded off. Responsibility for errors or omissions not accepted.

The cover features the vehicle with possible optional equipment. Some options may not be available in every region or country.

Photographs and graphics are symbolic representations and may differ from the actual products.

Wacker Neuson is authorized to publish copyright-protected material, for example that owned by Perkins Engines Company Ltd.

The Operator's Manual and any amendments to it must always be available at the location where the vehicle is operated. Possible amendments are included at the end of the Operator's Manual.



Wacker Neuson Linz GmbH

Flughafenstr. 7

A-4063 Hörsching

Phone: +43 (0) 7221 63000

Fax: +43 (0) 7221 63000-2200

E-mail: office.linz@wackerneuson.com

www.wackerneuson.com

## Table of contents

<b>1 Foreword</b>	
1.1 Operator's manual .....	1-1
1.2 Warranty and liability .....	1-8
<b>2 Safety</b>	
2.1 Safety symbols and signal words .....	2-1
2.2 Qualification of operating personnel .....	2-2
2.3 Conduct .....	2-3
2.4 Operation .....	2-4
2.5 Lifting gear applications .....	2-8
2.6 Trailer operation .....	2-11
2.7 Attachment operation .....	2-11
2.8 Towing, loading and transporting .....	2-13
2.9 Maintenance .....	2-15
2.10 Measures for avoiding risks .....	2-18
<b>3 Introduction</b>	
3.1 Machine overview .....	3-1
3.2 Brief description of the vehicle .....	3-2
3.3 Information and regulations on use .....	3-4
3.4 Labels .....	3-5
<b>4 Putting into operation</b>	
4.1 Cab .....	4-1
4.2 Overview of control elements .....	4-23
4.3 Control and warning lights overview .....	4-28
4.4 Preparatory work .....	4-31
4.5 Starting and stopping the engine .....	4-36
<b>5 Operation</b>	
5.1 Steering system .....	5-1
5.2 Accelerator actuation .....	5-2
5.3 Brake .....	5-3
5.4 Machine travel .....	5-4
5.5 Differential lock .....	5-9
5.6 Lights/signaling system .....	5-10
5.7 Washer system .....	5-13
5.8 Temperature setting .....	5-14
5.9 Operating hydraulics .....	5-15
5.10 Additional control circuits .....	5-25
5.11 Attachments .....	5-37
5.12 Work operation .....	5-42
5.13 Emergency lowering .....	5-57
5.14 Options .....	5-58
5.15 Immobilization/putting back into operation .....	5-61
5.16 Permanently putting out of operation .....	5-63
<b>6 Transportation</b>	
6.1 Towing the vehicle .....	6-1
6.2 Loading the vehicle .....	6-2
6.3 Transporting the vehicle .....	6-7

<b>7</b>	<b>Maintenance</b>	
7.1	Information on maintenance .....	7-1
7.2	Maintenance overview .....	7-2
7.3	Fluids and lubricants .....	7-13
7.4	Maintenance accesses .....	7-16
7.5	Cleaning and maintenance .....	7-18
7.6	Lubrication work.....	7-22
7.7	Fuel system .....	7-22
7.8	Engine lubrication system.....	7-28
7.9	Cooling system .....	7-30
7.10	Air filter.....	7-33
7.11	V-belt .....	7-34
7.12	Hydraulic system .....	7-35
7.13	Electrical system.....	7-40
7.14	Heating, ventilation and air conditioning system.....	7-41
7.15	Washer system .....	7-41
7.16	Travel drive .....	7-41
7.17	Braking system .....	7-41
7.18	Tracks .....	7-42
7.19	Maintenance of attachments.....	7-45
7.20	Maintenance of options.....	7-45
7.21	Exhaust gas treatment.....	7-46
7.22	Machine preservation .....	7-46
<b>8</b>	<b>Troubleshooting</b>	
8.1	Diesel engine malfunctions.....	8-1
8.2	Malfunctions.....	8-1
8.3	Malfunctions of the hydraulic system.....	8-2
8.4	Malfunctions of attachments .....	8-2
<b>9</b>	<b>Technical data</b>	
9.1	Models and trade names .....	9-1
9.2	Engine.....	9-1
9.3	Traveling drive .....	9-2
9.4	Brake .....	9-2
9.5	Tracks .....	9-2
9.6	Steering system .....	9-2
9.7	Work hydraulics .....	9-2
9.8	Electrical system.....	9-3
9.9	Tightening torques .....	9-7
9.10	Coolant .....	9-8
9.11	Noise emissions.....	9-8
9.12	Vibrations.....	9-9
9.13	Weights.....	9-9
9.14	Lift capacity/load .....	9-12
9.15	Dimensions .....	9-24
	.....	S-1

Not available.



Notes:

# 1 Foreword

## 1.1 Operator's manual

### Information on this Operator's Manual

The operator's manual is stored in the compartment under the seat.

A document box behind the seat is available as an option.

This operator's manual contains important information on how to work safely, correctly and economically with the vehicle. Therefore, it aims not only at new personnel, but it also serves as a reference for experienced personnel.

Furthermore, the reliability and the service life of the vehicle will be increased by following the instructions in the Operator's Manual. This is why the Operator's Manual must be kept at hand in the vehicle.

The operator must carefully read and understand the Operator's Manual before starting up, servicing or repairing the vehicle.

This Operator's Manual will help to familiarize yourself more easily with the vehicle, thereby enabling you to use it more safely and efficiently.

This Operator's Manual does not include special superstructures.

Please contact your dealer if you require more information on the vehicle or the Operator's Manual.

---

## Explanation of symbols and abbreviations

### Explanation of symbols

- Identifies a list
  - Identifies a subdivision of a list
  - Description of a result
- 1. Identifies an activity  
Follow the order of the activity!
- 2. Continuation of an activity  
Follow the order of the activity!
- A** Identifies an alphabetical list
- B** Continuation of an alphabetical list
- Cross references: see page *1-1* (page)
- Cross references: **7** (pos. no. or table no.)
- Cross-references: *Fig. 2* (Fig. no. 2)
- Cross references: – see chapter “5 Operation” on page 5-1 (see chapter)
- Cross references: – see “Operation” on page 5-1 (-see text)



### Information

Identifies an information that, when followed, provides for a more efficient and economical use of the vehicle.



### Environment

Failure to observe the instructions identified by this symbol can cause damage to the environment.

---



**Abbreviations**

Fig.	=	Figure
AUX	=	Additional control circuit
o/h	=	Operating hours
approx.	=	approximately
DPF	=	Diesel particulate filter
FGPS	=	Front Guard Protective Structure
FOPS	=	Falling Objects Protective Structure
HSWS	=	Hydraulic quickhitch (for example Easy Lock)
max.	=	maximum
min.	=	minimum
MSWS	=	Mechanical quickhitch
Item	=	Position
ROPS	=	Roll Over Protective Structure (without losing contact with the ground)
TOPS	=	Tip Over Protective Structure
e. g.	=	for example

## Glossary

Attachment	All exchangeable equipment (for example buckets) released by Wacker Neuson and developed for work with the vehicle.
Working lights	The lights on the roof, chassis and boom are referred to as working lights.
Towing	The excavator is towed out of an immediate danger zone (railroad crossing or job site, for example).
Canopy	Open safety component for the operator
Operating company/person	A company (or person) operating the vehicle. This can be a job site operating company, for example.
Operator	Person performing vehicle travel or operation.
vehicle	Unless otherwise specified, the term " <b>machine</b> " refers to the excavator described in this Operator's Manual. In some cases the vehicle is also referred to as excavator to avoid confusion with other vehicles.
Machine operation	All work (for example vehicle travel, moving material, daily maintenance work) an operator is allowed to do or has to perform in connection with the vehicle. The term " <b>vehicle operation</b> " does not include maintenance only a Wacker Neuson service center is allowed to perform.
Lift capacity table	The maximum weight which may be lifted in excavating operations. If the upper carriage is rotated, pay attention to the values of the <b>load diagrams</b> .
Cab	Closed safety component for the operator. The term <b>cab</b> is used in this operator's manual for canopy and cab. If there are differences, these two safety components are described separately.
Crawling speed	Perform vehicle travel as slowly as possible and jerk free.
Hose rupture	Hydraulic oil under pressure escapes from a hydraulic hose.
Check the threaded fittings for tightness	Check threaded fittings and associated components for tightness by visual check or manually (without using a tool). In case of loose screw connections, contact authorized service center
Visual aids	Visual aids are, for example, rearview mirrors, cameras, but also persons assisting the operator during vehicle operation.
Control lever base	The foldable control lever base on the left.

China III	The vehicles comply with different exhaust-gas standards depending on optional equipment. Engine variants are described separately if there are engine-specific differences (for example regarding operation).
Load diagram	Specifies the maximum load at a given boom extension with which the upper carriage may be rotated by 360° and the excavator may travel in creep gear with the stabilizer blade raised without tipping over.
Loading weight	The actual weight of the vehicle at the beginning of transportation. This weight refers to vehicles which are equipped exclusively with options approved by Wacker Neuson.
Additional control circuits	Additional control circuits required for certain attachments. <ul style="list-style-type: none"> <li>• AUX I: auxiliary hydraulics (for example for hydraulic hammer or offset bucket)</li> <li>• AUX II: 3rd control circuit (for example for universal grab)</li> <li>• AUX III: for example Powertilt</li> <li>• AUX IV: hydraulic quickhitch (for example Easy Lock)</li> <li>• AUX V: oscillating grab</li> </ul>

### Right/left/front/rear

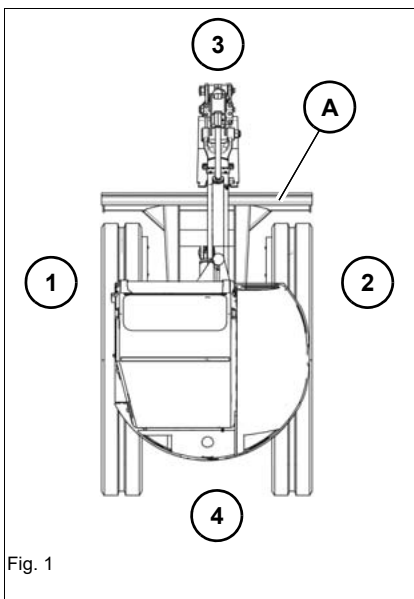

These terms are used from the view of an operator in the cabin if the front of the cabin faces toward the dozer blade **A**.

- **1**: left
- **2**: right
- **3**: front
- **4**: rear

## Target-group definition

This Operator's Manual is intended for professional construction site personnel.

Any operator must have fully read and understood this Operator's Manual completely.

A dealer or person renting the vehicle must instruct the operator and have this confirmed in writing.

## Operator qualification and requirements for safe operation

Among other things, safe vehicle operation depends on the following points:

- Machine model and its outfitting
- Machine maintenance
- Work and driving speed
- Nature of ground and work environment

The most important points are the operator's qualification and power of judgment. A well-trained operator following the operator's manual and maintenance plan ensures a long service life and durability of the vehicle.

Specific training enables the operator to acquire, among other things, the following skills:

- Correct assessment of work situations
- Feeling for the vehicle
- Recognition of possible risk situations
- Safe working by making the correct decisions for man, vehicle and the environment

The operator is at risk if the vehicle is not operated correctly.

Follow the operating procedures and instructions described for the vehicle.

Access to the vehicle or vehicle operation is prohibited for children and persons under the influence of alcohol, drugs, or medicine.

**Conversion table**

The rounded imperial values are indicated in brackets, for example 1060 cm<sup>3</sup> (64.7 in<sup>3</sup>).

<b>Volume unit</b>	
1 cm <sup>3</sup>	(0.061 in <sup>3</sup> )
1 m <sup>3</sup>	(35.31 ft <sup>3</sup> )
1 ml	(0.034 US fl.oz.)
1 l	(0.26 gal)
1 l/min	(0.26 gal/min)
<b>Unit of length</b>	
1 mm	(0.039 in)
1 m	(3.28 ft)
<b>Weight</b>	
1 kg	(2.2 lbs)
1 g	(0.035 oz)
<b>Pressure</b>	
1 bar	(14.5 psi)
1 kg/cm <sup>2</sup>	(14.22 lbs/in <sup>2</sup> )
<b>Force/output</b>	
1 kN	(224.81 lbf)
1 kW	(1.34 hp)
1 PS	(0.986 hp)
<b>Torque</b>	
1 Nm	(0.74 ft.lbs.)
<b>Speed</b>	
1 kph	(0.62 mph)
<b>Acceleration</b>	
1 m/s <sup>2</sup>	(3.28 ft/s <sup>2</sup> )

## 1.2 Warranty and liability

### Exemption from warranty and liability

#### Warranty

Warranty claims can be made only if the conditions of warranty have been observed. They are included in the General Conditions of Sales and Delivery for new vehicles and spare parts sold by the dealers of Wacker Neuson Linz GmbH. Furthermore, all instructions in this Operator's Manual must be observed.

Have the maintenance, delivery inspection and the entries in the service booklet performed by a Wacker Neuson service center, otherwise warranty claims will not be acknowledged.

#### Exemption from liability

- Modifying Wacker Neuson products and fitting them with additional equipment and attachments that are not included in our delivery program requires Wacker Neuson's written authorization, otherwise warranty and product liability for possible damage caused by these modifications shall not be applicable.
- The safety of the vehicle can be negatively affected by performing vehicle modifications without proper authority and by using spare parts, equipment, attachments and optional equipment that have not been checked and released by Wacker Neuson. Warranty and product liability for possible damage caused by these modifications shall not be applicable.
- Wacker Neuson Linz GmbH shall not be liable for injury and/or damage to property caused by failure to observe the safety instructions, warnings and the Operator's Manual, and by the negligence of the duty to exercise due care when:
  - handling
  - Operating
  - servicing and performing maintenance
  - repairing the vehicle. This is also applicable in those cases in which special attention has not been drawn to the duty to exercise due care, in the safety instructions as well as in the Operator's and maintenance manuals.
  - Read and understand the Operator's Manual before starting up, servicing or repairing the vehicle. Observe all safety instructions and warnings.

## 2 Safety

### 2.1 Safety symbols and signal words

#### Explanation

The following symbol identifies safety instructions. It is used for warning against potential personal risk or danger.

---

#### **DANGER**

**DANGER identifies a situation causing death or serious injury if it is not avoided.**

Consequences in case of non-observance.

- ▶ Avoidance of injury or death.
- 

#### **WARNING**

**WARNING identifies a situation that can cause death or serious injury if it is not avoided.**

Consequences in case of non-observance.

- ▶ Avoidance of injury or death.
- 

#### **CAUTION**

**CAUTION identifies a situation that can cause injury if it is not avoided.**

Consequences in case of non-observance.

- ▶ Avoidance of injury.
- 

#### **NOTICE**

**NOTICE identifies a situation that causes damage to the vehicle if it is not observed.**

- ▶ Avoidance of damage to property.
-

## 2.2 Qualification of operating personnel

### Owner's duties

- Only allow specifically authorized, trained and experienced persons to operate, drive and perform maintenance on the vehicle.
- Do not allow persons to be trained or instructed by anyone other than an authorized and experienced person.
- Have persons to be trained or instructed practice under supervision until they are familiar with the machine and its behavior (for example with the steering and braking behavior).
- Access to the vehicle or vehicle operation is prohibited for children and persons under the influence of alcohol, drugs or medicine.
- Clearly and unequivocally define the responsibilities of the operating and maintenance personnel.
- Clearly and unequivocally define the responsibilities on the job site, also in view of traffic regulations.
- Give the operator the authority to refuse safety instructions from third parties.
- Have the vehicle serviced and repaired only by an authorized service center.

### Required knowledge of the operator

- The operator is responsible for third parties.
- Avoid any operational mode that might be prejudicial to safety.
- The specific national driving license is required.
- The vehicle may only be operated by authorized and safety-conscious persons who are fully aware of the risks involved in operating the vehicle.
- The operator and owner are obligated to operate the vehicle only in a safe and working condition.
- All persons working on or with the vehicle must have read and understood the safety instructions in this Operator's Manual before starting work.
- Follow, and instruct the operator in, legal and other mandatory regulations relevant to accident prevention.
- Observe and instruct the operator in regulations regarding road traffic and environmental protection.
- Use only the defined accesses for getting on and off the vehicle.
- Be familiar with the emergency exit of the vehicle.



## **Preparatory measures for the operator**

- Before starting, check the vehicle whether it can be driven and operated safely.
- Tie back long hair and remove all jewelry.
- Wear close-fitting work clothes that do not hinder movement.

## **2.3 Conduct**

### **Prerequisites for operation**

- The vehicle has been designed and built in accordance with state-of-the-art standards and the recognized safety regulations. Nevertheless its use can cause danger to the operator or third parties, or damage to the vehicle.
- Store this Operator's Manual in the place provided for this in or on the vehicle. Immediately replace a damaged or illegible Operator's Manual and any supplements to it.
- The vehicle must only be operated in accordance with its designated use and the instructions set forth in this Operator's Manual.
- The operator and owner are obligated not to put a damaged or malfunctioning vehicle into operation or operate it.
  - If a damage or malfunction occurs during operation, put the vehicle out of operation immediately and secure it against restart.
  - Have all malfunctions jeopardizing the safety of the operator or third parties immediately repaired by an authorized service center.
- Do not put the vehicle into operation or operate it after an accident; have it inspected for damage by an authorized service center.
  - Have the seat belt replaced by an authorized service center after an accident, even if there is no visible damage.
  - Cabin and protective structures
- Remove all dirt, snow and ice from climbing aids (for example from the handholds, footholds, handrails).
- The owner is responsible for requiring the operating and maintenance personnel to wear protective clothing and equipment as required by the circumstances.

### 2.4 Operation

#### Preparatory measures

- Operation is only allowed with correctly installed and intact protective structures.
- Keep the vehicle clean. This reduces injury, accident and fire hazards.
- Safely store objects you carry with you in the places provided for this (for example in the storage compartment, drinks holder).
- Do not carry objects with you that protrude into the user's work space. They can create another danger in case of an accident.
- Observe all safety, warning and information labels.
- Start and operate the vehicle only with the seat belt fastened and only from the place provided for this.
- Check the condition and the fastening of the seat belt. Have malfunctioning seat belts and mounting hardware replaced by an authorized service center.
- Before starting work, adjust the seating position so that all control elements can be reached and fully operated.
- Only make personal settings when the vehicle is at a standstill (e.g. seat, steering column).
- Ensure that all safety devices are properly installed and functional before starting work.
- Before starting work or after interrupting work, ensure that the brake, steering, signaling and light systems are functional.
- Before putting the vehicle into operation, ensure that nobody is in the danger zone.

## Job site

- The operator is responsible for third parties.
- Before starting work, familiarize yourself with the job site. This applies to, for example:
  - Obstacles in the job site and vehicle travel area
  - Any barriers separating the job site from public roads
  - Soil weight-bearing capacity
  - Existing overhead and underground lines
  - Special operating conditions (for example dust, steam, smoke, asbestos)
- The operator must know the maximum dimensions of the vehicle and the attachment – see “Technical data”.
- Maintain a safe distance (for example from buildings, edges of building pits).
- During work in buildings or in enclosed areas, look out for:
  - Height of the ceiling/clearances
  - Width of entries/passages
  - Maximum load of ceilings and floors
  - Sufficient room ventilation (for example risk of carbon monoxide poisoning)
- Use existing visual aids to stay aware of the danger zone.
- In conditions of darkness and poor visibility, switch on existing work lights and ensure that motorists are not blinded by these lights.
- If the existing lights of the vehicle are not sufficient for performing work safely, ensure additional lighting of the job site.
- Due to hot vehicle parts, maintain a safe distance from easily flammable material (for example from hay, dry leaves).

## Danger zone

- The danger zone is the area in which persons are in danger due to the movements of the vehicle, attachment and/or load.
- The danger zone also includes the area that can be affected by falling material, equipment or by parts that are thrown out.
- Extend the danger zone sufficiently in the immediate vicinity of buildings, scaffolds or other elements of construction.
- Seal off the danger zone should it not be possible to keep a sufficient safety distance.
- Stop vehicle operation immediately if persons do not stay clear of the danger zone.

### Carrying passengers

- Carrying passengers with the vehicle is PROHIBITED.
- Carrying passengers on/in attachments/tools is PROHIBITED.
- Carrying passengers on/in trailers is PROHIBITED.

### Mechanical integrity

- The operator and owner are obligated to operate the vehicle only in a safe and working condition.
- Operate the machine only if all protective and safety-oriented equipment (for example protective structures such as a cabin or rollbar, removable safety devices) is installed and functional.
- Check the vehicle for visible damage and defects.
- In case of damage and/or unusual behavior, put the vehicle out of operation immediately and secure it against restart.
- Have all malfunctions jeopardizing the safety of the operator or third parties immediately repaired by an authorized service center.

### Starting the engine of the vehicle

- Start the engine only according to the Operator's Manual.
- Observe all warning and indicator lights.
- Do not use any liquid or gaseous starting aids (for example ether or starting fuel).

## Machine operation

- Start and operate the vehicle only with the seat belt fastened and only from the place provided for this.
- Put the vehicle into operation only if visibility is sufficient (have another person guide you if necessary).
- Operation on slopes:
  - Travel/work only uphill or downhill.
  - Avoid vehicle travel across a slope, observe the vehicle's permissible inclination (and of the trailer if necessary).
  - Keep loads on the uphill side of the vehicle and as close as possible to it.
  - Keep attachments/work equipment close to the ground.
- Adapt the travel speed to the circumstances (for example the ground conditions, weather conditions).
- There is increased danger during backward vehicle travel. Persons in the blind spot of the vehicle cannot be seen by the operator.
  - Ensure that nobody is in the danger zone when you change the travel direction.
- Never get on a moving vehicle and never jump off the vehicle.

## Machine travel on public roads/sites

- The specific national driving license is required.
- Observe the national regulations (for example the road traffic regulations) during machine travel on public roads/sites.
- Ensure that the vehicle is in compliance with the national regulations.
- In order not to blind other motorists, using the existing work lights during vehicle travel on public roads/site is prohibited.
- When crossing underpasses, bridges, tunnels, for example, ensure that the clearance height and width is sufficient.
- The attachment fitted onto the machine must be certified for travel on public roads/sites (see for example the registration documents).
- The attachment fitted onto the vehicle must be empty and in transport position.
- The attachment fitted onto the vehicle must be equipped with the mandatory lights and protective equipment.
- Take measures against unintentional operation of the operating hydraulics.
- If the vehicle has different steering modes, ensure that the mandatory steering mode is selected.

### Stopping the engine of the vehicle

- Stop the engine only according to the Operator's Manual.
- Before stopping the engine, lower the work equipment/attachment to the ground.

### Stopping and securing the vehicle

- Unbuckle the seat belt only after stopping the engine.
- Before leaving the machine, secure it to prevent it from rolling away (for example with the parking brake, suitable wheel chocks).
- Remove the starting key and secure the vehicle against unauthorized operation.

## 2.5 Lifting gear applications

### Requirements

- Have loads fastened and the operator guided by a qualified person who has specific knowledge of lifting gear applications and the usual hand signals.
- The person giving instructions to the operator must stay in visual contact with the operator when fastening, guiding or removing the load (maintain visual contact).
- If this not be possible, ask one more person with the same qualifications to guide.
- The operator may not leave his seat as long as the load is raised.

## **Fastening, guiding and removing loads**

- Follow the applicable specific regulations for fastening, guiding and removing a load.
- Wear protective clothing and equipment when fastening, guiding and removing loads (for example a hard hat, safety glasses, protective gloves, safety boots).
- Do not place lifting and fastening gear over sharp edges or rotating parts. Loads must be fastened so as to prevent them from slipping or falling.
- Move loads only on horizontal, level and firm ground.
- Move loads close to the ground.
- In order to avoid oscillating movements of loads:
  - Perform smooth, slow movements with the vehicle.
  - Use cables to guide the load (do not use hands to guide).
  - Bear in mind the weather conditions (for example the wind force).
  - Keep a minimum safety distance from objects.
- The operator may allow the load to be fastened and removed only if the vehicle and its work equipment are not being moved.
- Danger zones must not overlap with the work zones of other vehicles.



### Lifting gear applications

- The vehicle must be certified for lifting gear applications.
- Observe the national regulations for lifting gear applications.
- Lifting gear applications are procedures involving raising, transporting and lowering loads with the help of lifting and fastening gear.
- The help of an accompanying person is necessary for fastening, guiding and removing the load.
- There must be nobody under the load.
- Stop the vehicle immediately and stop the engine if persons enter the danger zone.
- Use the machine for lifting gear applications ONLY if the mandatory lifting gear (for example a joint rod and load hook) and safety equipment (for example optical and acoustic warning devices, hose burst valve, stability table) is installed and functional.
- Use only lifting and fastening gear certified by a test/certification body, observe the inspection intervals (Use only chains and shackles. No belts, slings or cables).
- Do not use any lifting and fastening gear that is dirty, damaged or not of sufficient size.
- Do not interrupt the work process with a load attached.



## 2.6 Trailer operation

### Trailer operation

- The vehicle must be certified for trailer operation.
- Observe the national regulations for trailer operation.
- The specific national driving license is required.
- Carrying passengers on/in trailers is PROHIBITED.
- Observe the maximum permissible vertical and trailer load.
- Do not exceed the permissible trailer speed.
- Trailer operation with the towing gear of the vehicle is prohibited.
- Trailer operation changes the vehicle's operating behavior; the operator must be familiar with this and act accordingly.
- Bear in mind the vehicle's steering mode and the trailer's turning circle.
- Before hitching/unhitching the trailer, secure it to prevent it from rolling away (for example with the parking brake, suitable wheel chocks).
- There must be nobody between the vehicle and the trailer when hitching a trailer.
- Hitch the trailer onto the vehicle correctly.
- Ensure that all equipment works correctly (for example the brakes, lights).
- Before starting vehicle travel, ensure that nobody is between the vehicle and the trailer.

## 2.7 Attachment operation

### Attachments

- Use only attachments that are certified for the machine or its protective equipment (for example a shatter protection).
- All other attachments require the vehicle manufacturer's release.
- The danger zone and the work zone depend on the attachment used – see the Operator's Manual of the attachment.
- Secure the load.
- Do not overload attachments.
- Check the correct position of the lock.



### Operating

- Carrying persons on/in an attachment is prohibited.
- Installing a work platform is prohibited.
  - Exception: The vehicle is certified and equipped with the necessary safety equipment.
- Attachments and counterweights modify handling, as well as the steering and brake capability of the vehicle.
- The operator must be familiar with these modifications and act accordingly.
- Before starting work, operate the attachment to check that it works correctly.
- Before putting the attachment into operation, ensure that nobody is in danger.
- Lower the attachment to the ground before leaving the seat.

### Removing and fitting attachments

- Before uncoupling or coupling hydraulic connections:
  - Stop the engine
  - Release the pressure in the operating hydraulics
- Picking up and lowering attachments to the ground requires special care:
  - Pick up and safely lock the attachment in accordance with the Operator's Manual.
  - Lower the attachment only to firm, level ground and secure it to prevent it from tipping over or rolling away.
- Put the vehicle and the attachment into operation only if:
  - The protective equipment has been installed and is functional.
  - The connections for the lights and the hydraulic system have been established and are functional.
- Perform a visual check of the lock after locking the attachment.
- There must be nobody between the vehicle and the equipment when picking up or lowering an attachment to the ground.

## 2.8 Towing, loading and transporting

### Towing

- Seal off the danger zone.
- Ensure that no one is near the towing bar or cable. The safety distance is equal to 1.5 times the length of the towing equipment.  
Use a towing cable for vehicles with a total weight of up to 4.0 tons.  
Use a towing bar for vehicles with a total weight of over 4.0 tons.
- Observe the mandatory transport position, permissible speed and itinerary.
- A tractor vehicle of the same weight category must be used as a minimum. Furthermore, the tractor vehicle must be equipped with a safe braking system and sufficient tractive power.
- Use only towing bars or cables certified by a test/certification body, observe the inspection intervals.
- Do not use any towing bars or cables that are dirty, damaged or not of sufficient size.
- Fasten towing bars or cables only at the defined points.
- Tow away only in accordance with this Operator's Manual to avoid damage to the vehicle.
- Observe the national regulations (for example the light regulations) when towing on public roads/sites.

### Crane-lifting

- Seal off the danger zone.
- The crane and the lifting gear must have suitable dimensions.
- Observe the vehicle's overall weight – see "Technical data".
- Wear protective clothing and equipment when fastening, guiding and removing the machine (for example a hard hat, safety glasses, safety boots).
- Use only lifting and fastening gear certified by a test/certification body (for example cables, belts, hooks, shackles), observe the inspection intervals.
- Do not use any lifting and fastening gear that is dirty, damaged or not of sufficient size.
- Perform a visual check to ensure that all slinging points are neither damaged nor worn (no widening, no sharp edges, no cracks).
- Have loads fastened and crane operators only guided by experienced persons.
- The person guiding the crane operator must be within sight or sound of him.
- Observe all movements of the vehicle and lifting gear.
- Secure the vehicle against unintentional movement.
- Raise the vehicle only after it is safely attached and the person attaching the vehicle has given his approval.
- Use only the slinging points provided for fastening the lifting gear (for example cables, belts).
- Do not attach the machine by twining the lifting gear (for example cables, belts) around it.
- Ensure an even load distribution (center of gravity!) when fastening the lifting gear.
- Ensure that no one is in, on or under the vehicle when loading the vehicle.
- Observe the national regulations (for example "Merkheft Erdbau-maschinen", leaflet on earth moving machines of the German employers' liability insurance association for construction engineering).
- Load the vehicle only in accordance with this Operator's Manual to avoid damage to the vehicle.
- Do not raise a machine that is stuck or frozen onto the ground, for example.
- Bear in mind the weather conditions (for example the wind force, visibility conditions).

## Transportation

- For the safe transportation of the vehicle:
  - The transport vehicle must have a sufficient load capacity and platform – see “Technical data”
  - The maximum weight rating of the transport vehicle must not be exceeded.
- Use only lifting and fastening gear certified by a test/certification body, observe the inspection intervals.
- Do not use any lifting and fastening gear that is dirty, damaged or not of sufficient size.
- In order to secure the vehicle on the platform, use only the fastening points provided for this purpose.
- Ensure that nobody is in or on the vehicle during transportation.
- Observe the national regulations (for example “Merkheft Erdbau-maschinen”, leaflet on earth moving machines of the German employers’ liability insurance association for construction engineering).
- Bear in mind the weather conditions (for example ice, snow).
- Ensure the minimum load on the steering axle(s) of the transport vehicle, and ensure an even load distribution.

## 2.9 Maintenance

### Maintenance

- Observe the intervals prescribed by law and those specified in this Operator’s Manual for routine checks/inspections and maintenance.
- For inspection and maintenance, ensure that all tools and service center equipment are adapted to the performance of the task described in this Operator’s Manual.
- Do not use any damaged or malfunctioning tools.
- The vehicle and the engine must be stopped during maintenance.
- Once maintenance is over, correctly install safety equipment again that has been removed.
- Wait for the vehicle to cool down before touching components.

### Personal safety measures

- Avoid any operational mode that might be prejudicial to safety.
- Wear protective clothing and equipment (for example a hard hat, protective gloves, safety boots).
- Tie back long hair and remove all jewelry.
- If maintenance on a running engine cannot be avoided:
  - Only work in groups of two.
  - Both persons must be authorized and trained for the operation of the vehicle.
  - One person must be seated on the seat and stay in contact with the second person.
  - Keep a safe distance from rotating parts (for example from fan blades, belts).
  - Keep a safe distance from hot parts (for example from the exhaust system).
  - Perform maintenance only in well-ventilated rooms or rooms with an exhaust-gas suction system.
- Safely lock/support vehicle components before starting work.
- Apply special care when working on the fuel system due to the increased fire hazard.

## Preparatory measures

- Attach a warning label to the control elements (for example “Machine being serviced, do not start”).
- Before performing assembly work on the vehicle, support the areas to be serviced and use suitable lifting and supporting equipment for the replacement of parts over 9 kg (20 lbs.).
- Perform maintenance only if:
  - the vehicle is positioned on firm and level ground
  - the machine is secured to prevent it from rolling away (for example with the parking brake, wheel chocks), and if all attachments/the work equipment is lowered to the ground
  - the engine is stopped
  - the starting key has been removed
  - the pressure in the operating hydraulics has been released
- If maintenance has to be performed under a raised machine/attachment, support the machine/attachment (for example with a lift platform, trestles) ensuring safety and stability.
- Hydraulic cylinders or jacks alone do not sufficiently secure a raised vehicle/attachment.

## Measures for performing maintenance

- Perform only the maintenance described in this Operator’s Manual.
- All work that is not described in this Operator’s Manual must be performed by qualified and authorized technical personnel.
- Follow the maintenance plan – see “Maintenance plan”.
- Always use specially designed or otherwise safety-oriented ladders and working platforms to perform overhead maintenance. Do not use vehicle parts or attachments as a climbing aid.
- Do not use attachments/work equipment as a lift platform for persons.
- Remove all dirt, snow and ice from climbing aids (for example from the handholds, footholds, handrails).
- Disconnect the negative terminal of the battery before working on the electrical system.

### Modifications and spare parts

- Do not modify the machine and the work equipment/attachment (for example the safety equipment, lights, tires, straightening and welding work).
- Modifications must be approved by the manufacturer and performed by an authorized service center.
- Use only original spare parts.

### Protective structures

- The cab, rollbar and protective grate are tested protective structures and may not be changed (e.g. no drilling, bending, welding).
- Perform a visual check according to the maintenance plan (for example check fastenings for damage).
- If damage or defects are detected, have them immediately checked and repaired by an authorized service center.
- Have retrofitting work only performed by an authorized service center.
- Replace self-locking fasteners (for example self-locking nuts) by new ones after removing them.

## 2.10 Measures for avoiding risks

### Tires

- Have repair work on the tires only performed by trained technical personnel.
- Check the tires for correct pressure and visible damage (for example cracks, cuts).
- Tighten the wheel nuts to the specified tightening torque. (see chapter 7.18 Tires/tracks).
- Use only approved tires.
- The machine must have identical tires (for example profile, revolutions per mile).

### Tracks

- Repair work on tracks may be performed only by trained technicians.
- Check the tracks for correct tension and visible damage (for example cracks, cuts).
- Proceed with extreme care on slippery ground (for example on steel plates, ice), increased slipping hazard.
- Use only approved tracks.



## Hydraulic and compressed-air system

- Check all lines, hoses and screw connections regularly for leaks and visible damage.
- Splashed oil can cause injury and fire.
- Leaking hydraulic and compressed-air lines can cause the full loss of the brake effect.
- Have damage and leaks immediately repaired by an authorized service center.
- Have hydraulic hoses replaced by an authorized service center within recommended intervals.

## Electrical system

- Use only fuses with the specified current rating.
- In case of damage or malfunction in the electrical system:
  - Put the vehicle out of operation immediately and secure it against restart
  - Disconnect the battery or operate the battery master switch
  - Have the malfunction repaired
- Ensure that work on the electrical system is only performed by trained technical personnel.
- Have the electrical system checked regularly and malfunctions repaired immediately (for example loose connections, scorched cables).
- The operating voltage of machine, the attachment and the trailer must be the same (for example 12 V).

### Battery

---

#### **CALIFORNIA**

##### **Proposition 65 Warning**

Battery terminals, battery clamps, and related accessories contain lead and lead compounds. These chemicals are classified in the state of California as a cause for cancer and a reduction of fertility. Wash hands after handling.

---

- Batteries contain caustic substances (for example sulfuric acid). When handling the battery observe the specific safety instructions and regulations relevant to accident prevention.
- A volatile oxyhydrogen mixture forms in batteries during normal operation and especially during charging. Always wear gloves and eye protection when working with batteries.
- Do not perform battery maintenance near open flames.
- Perform battery maintenance only in well-ventilated areas (for example due to vapors harmful to health, explosion hazard).
- Starting the vehicle with battery jumper cables is dangerous if performed improperly. Observe the safety instructions regarding the battery.

---

## Safety instructions regarding internal combustion engines

---

### **CALIFORNIA**

#### **Proposition 65 Warning**

Engine exhaust, some of its constituents, and certain vehicle components contain or emit chemicals known to the State of California to cause cancer and birth defects or other reproductive harm.

---

- Internal combustion engines present special hazards during operation and fueling.
- Failure to follow the warnings and safety instructions can cause serious injury or death.
- Keep the area around the exhaust system free of flammable materials.
- Check the engine and fuel system for leaks (for example loose fuel lines). Don't start or let the engine run in case of leaks.
- Breathing the exhaust fumes causes death very quickly.
- Engine exhaust contains gases you cannot see or smell (for example carbon monoxide and dioxide).
  - Never operate the machine in enclosed premises or areas (for example in pits), if there is no suitable ventilation (for example exhaust-gas filters, suction systems).
- Do not operate the vehicle in potentially explosive areas.
- Do not touch the engine, exhaust system and cooling system as long as the engine is still running or has not cooled down yet.
- Do not remove the radiator cap when the engine is running or hot.
- The coolant is hot, under pressure and can cause serious burns.

### **Bleeding the fuel system and refueling**

- Do not bleed the fuel system or refuel near open flames.
- Bleed the fuel system and refuel only in well-ventilated areas (for example due to vapors harmful to health, explosion hazard).
- Wipe away fuel spills immediately (for example due to fire hazard, slipping hazard).
- Firmly close the fuel tank cap; replace a malfunctioning fuel tank cap.

### Handling oil, grease and other substances

- When handling oil, grease and other chemical substances (for example the battery acid, coolant), observe the safety data sheets.
- Wear appropriate protective equipment (for example protective gloves, safety glasses).
- Be careful when handling hot consumables – burn hazard.
- In polluted environment (dust, vapors, smoke, asbestos), work only with appropriate personal protective equipment (for example with a breathing mask).
- Do not operate the vehicle in radioactively, biologically or chemically contaminated areas.

### Fire hazard

- Fuel, lubricants and coolants are flammable.
- Do not put the vehicle into operation if there is a fire hazard.
- Do not use flammable detergents.
- Keep the area around the exhaust system free of flammable materials.
- Due to hot vehicle parts, maintain a safe distance from easily flammable material (for example from hay, dry leaves).
  - Stop and park the vehicle only in fire-protected areas.
- If the vehicle is equipped with a fire extinguisher, have it installed in its specific location.
- Keep the vehicle clean to reduce the fire hazard.

### **Working near electric supply lines**

- Before performing any work, the operator must check whether there are any electrical supply lines in the designated working area.
- If there are electrical supply lines, only a vehicle with cab may be used (Faraday cage).
- Keep a safe distance from existing electric supply lines.
- If this is not possible, the operator must initiate other safety measures in agreement with the owner or operator of the supply lines (e.g. shutdown the power).
- If supply lines are exposed, they must be fastened, supported and secured accordingly.
- If live supply lines are touched nevertheless:
  - Do not leave/touch the cab (Faraday cage)
  - If possible, drive the vehicle out of the danger zone
  - Warn others against approaching and touching the vehicle
  - Have the live wire de-energized
  - Do not leave the vehicle until the supply lines that have been touched or damaged have been safely de-energized.

### **Working near non-electric supply lines**

- Before performing any work, the operator must check whether there are any non-electrical supply lines in the designated working area.
- If non-electrical supply lines exist, the operator must initiate safety measures in agreement with the owner or operator of the supply lines (e.g. shutdown the supply line).
- If supply lines are exposed, they must be fastened, supported and secured accordingly.



### Behavior during thunderstorm

- Stop machine operation if a thunderstorm is gathering, stop the machine, secure and leave it, and avoid being near it.

### Noise

- Observe the noise regulations (for example, during applications in enclosed premises).
- Bear in mind external sources of noise (compressed-air hammer, concrete saw).
- Do not remove the sound baffles of the machine/attachment.
- Have damaged sound baffles immediately replaced (for example, an insulating mat, muffler).
- Before starting work, get informed on the noise level of the machine/attachment (for example on the adhesive label) – wear ear protectors.
- Do not wear ear protectors during machine travel on public roads/sites.

### Cleaning

- Risk of injury from compressed air and high-pressure cleaners.
  - Wear appropriate protective clothes.
- Do not use any dangerous and aggressive detergents.
  - Wear appropriate protective clothes.
- Operate the machine only in a clean condition.
  - Remove all dirt, snow and ice from climbing aids (for example from the handholds, footholds, handrails).
  - Keep the cabin glazing and visual aids clean.
  - Keep the light system and reflectors clean.
  - Keep the control elements and indicators clean.
  - Keep the safety, warning and information labels clean, and replace damaged and missing labels by new ones.
- Perform cleaning work only if the engine is stopped and cooled down.
- Bear in mind sensitive components and protect them accordingly (for example electronic control units, relays).

### 3 Introduction

#### 3.1 Machine overview

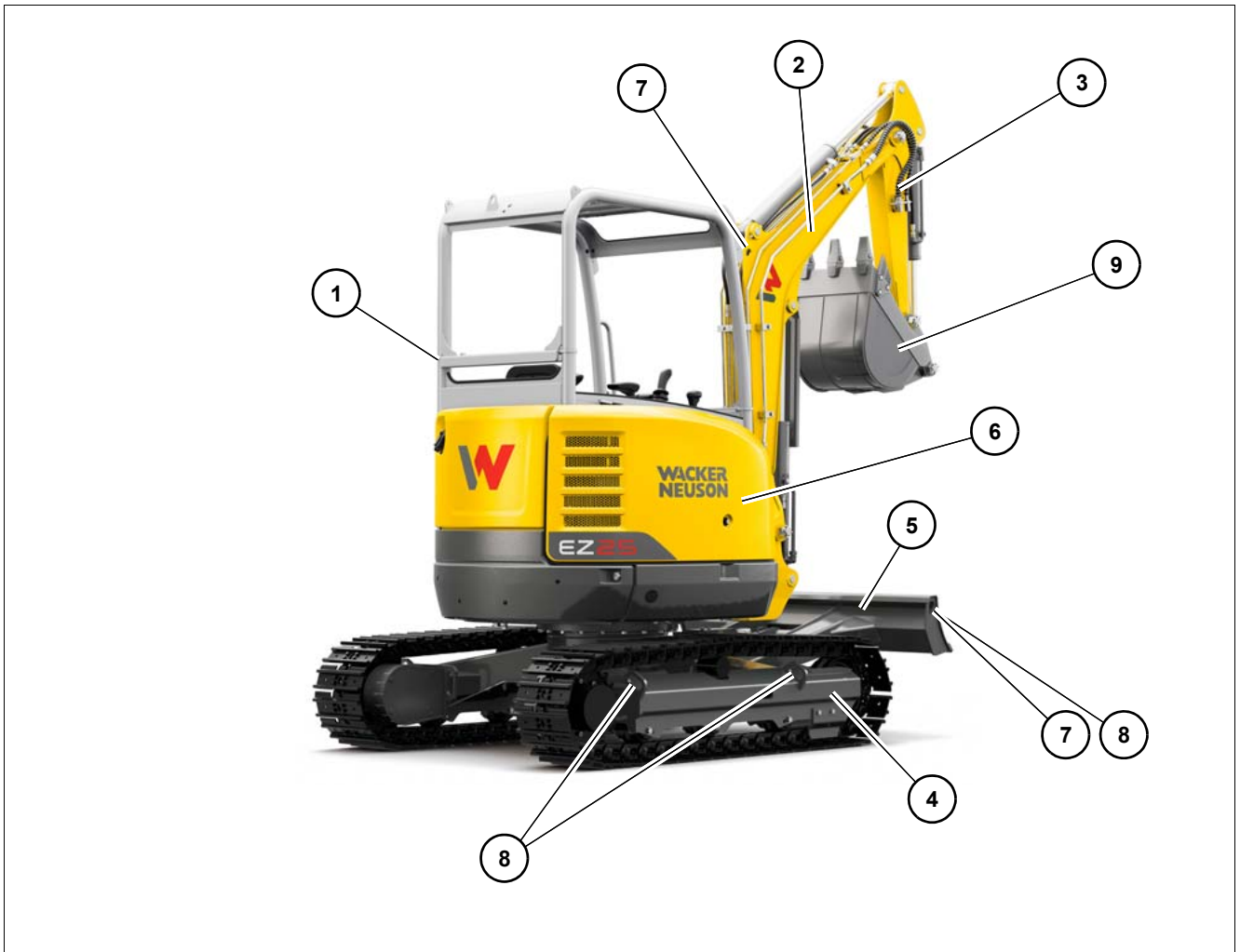

Item	Designation	See
1	Cab	<a href="#">4-1</a> ; <a href="#">4-13</a> ; <a href="#">4-24</a>
2	Boom	<a href="#">5-15</a>
3	Additional control circuits	<a href="#">5-22</a> ; <a href="#">5-25</a>
4	Chassis	<a href="#">7-42</a>
5	Stabilizer blade	<a href="#">5-21</a>
6	Engine cover	<a href="#">7-16</a>
7	Lifting eyes	<a href="#">6-6</a>
8	Tie-down points	<a href="#">6-3</a>
9	Attachments	<a href="#">9-10</a>

## Model designations and trade names

Machine model	Trade name	Engine
E30	EZ25	3TNV76
		3TNV80F

### 3.2 Brief description of the vehicle

The Wacker Neuson model E30 track excavators are self-propelled work vehicles.

These vehicles are powerful, highly flexible and efficient construction vehicles with minimum environmental impact. They are mainly used for loosening and moving earth, for example for digging and filling up construction pits. A wide range of attachments offers a large number of applications, for example hammer operation or bulk-material handling with a grab.

Other possible applications can be found in chapter [Technical data of attachments on page 9-11](#).



#### Information

The machine can be equipped with the **Telematic** option (for transmitting operating data, location, etc. via satellite).



**Safety components**

Safety component	Certificate	Availability
Canopy	TOPS	Standard
	ROPS	Standard
	FOPS (category I)	--
	Front Guard (category I)	--

**Definition of FOPS/Front Guard categories**

**Category I**

Protection against small falling objects (FOPS) or small objects penetrating into the cab from the front (front guard), such as bricks, small pieces of concrete, tools, for machines that are used for repairing roads, landscaping work and for working on other construction sites, for example.

**Category II**

Protection against heavy falling objects (FOPS) or heavy objects penetrating into the cabin from the front (Front Guard), for example trees or pieces of rock, for vehicles that are used for tasks such as clearance, demolition and forestry work.

**i Information**

Category II protective structures are not available for this vehicle.

**Superstructure Versions**

**ET:** conventional superstructure

**EZ:** Zero tail revolving superstructure; the upper carriage does not project over the width of the vehicle **without an additional weight** when rotating.

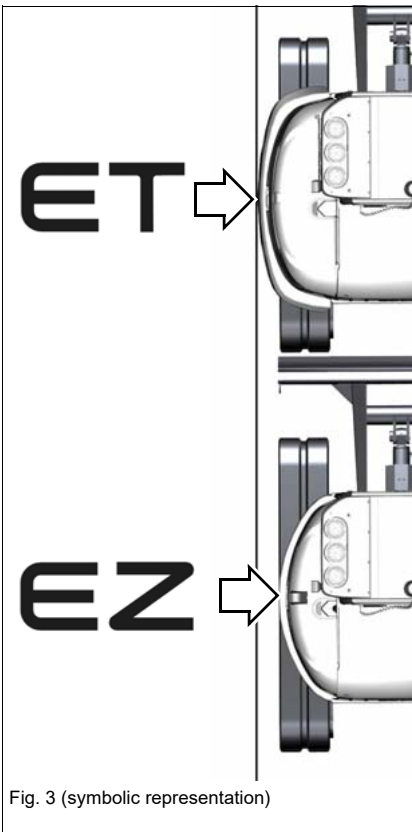

Fig. 3 (symbolic representation)

### 3.3 Information and regulations on use

#### Designated use

The vehicle is intended for:

- moving earth, gravel or rubble, for hammer and grab operation
- working only with the attachments indicated in chapter *Technical data of attachments on page 9-11*.
- Every other use is regarded as not designated for the use of the vehicle. Wacker Neuson will not be liable for damage resulting from use other than mentioned above. The user/operating company alone will bear the risk.

Designated use also includes observing the instructions set forth in the Operator's Manual and observing the maintenance and service conditions.

- The vehicle may not be used on public roads.
- In applications with lifting gear, the vehicle is used according to its designated use only if the mandatory devices are installed and functional.
- Use the quickhitch only with the corresponding attachments.
- A restricted work range applies to work with attachments (for example hammer) that can cause fragments to fly around.

## 3.4 Labels

---

### **WARNING**

#### **Injury hazard due to missing or damaged labels!**

An insufficient warning of dangers can cause serious injury or death.

- ▶ Do not remove warning and information labels.
  - ▶ Immediately replace damaged warning and information labels.
- 

---

### **Information**

Type, quantity, and position of the labels depend on options, country and vehicle.

---

---

### **Information**

The language on the stickers may differ from the representation in this document.

---

## Type labels



Fig. 4 (symbolic representation)

The vehicle type label is located at the left on the chassis.

### **Serial number**

The serial number is stamped on the vehicle chassis. It is also located on the type label.

Type label

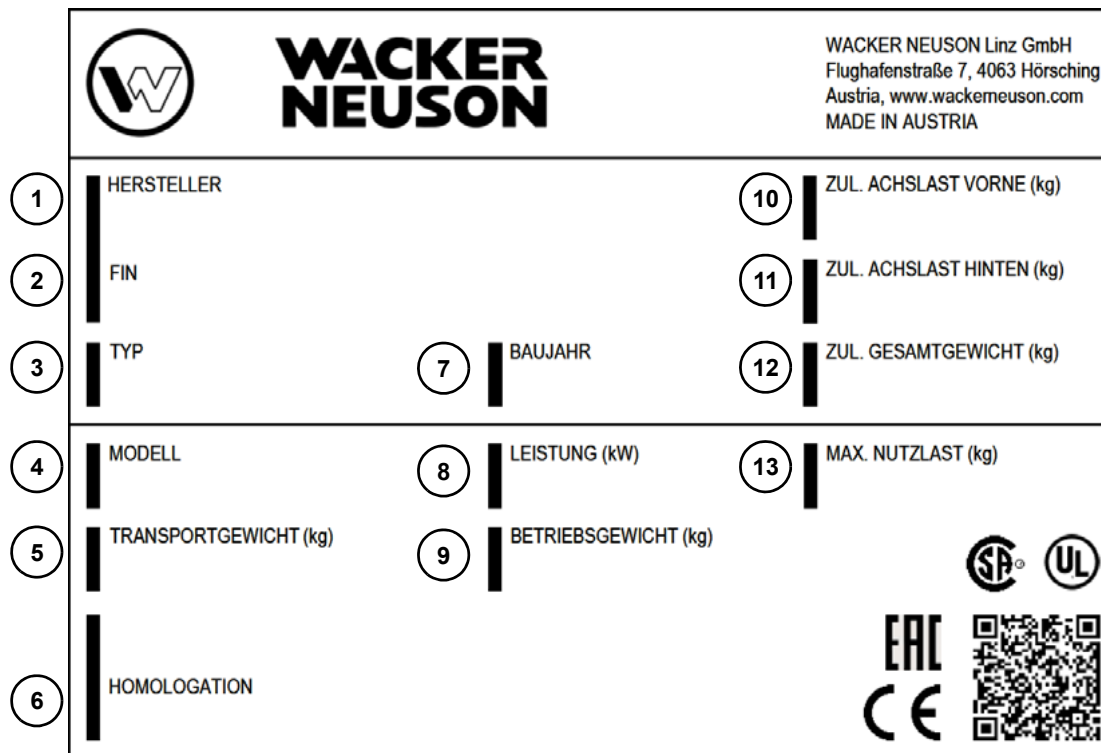

Nummer	Typenschild
1	Manufacturer
2	Machine serial number
3	Internal type designation
4	Trade name
5	Transport weight
6	Type approval
7	Year of construction
8	Engine power
9	Operating weight
10	Front gross axle weight rating
11	Rear gross axle weight rating
12	Gross weight rating (permissible)
13	Maximum payload

**i** Information

For better legibility, the type label is shown in bright colours. The language on the type label may vary.

### 17-digit serial number

The 17-digit serial number provides additional information for easier machine identification.

Manufacturer code	Machine model	Internal model designation	Check letter	Serial number
WNC (Austria) WNP (China)	E (Excavator)	1301	K	00012345
	D (Dumper)			
	A (Power unit)			

### Information

Wacker Neuson components (for example Easy Lock, tilt bucket, rollbar) have numeric serial numbers only.

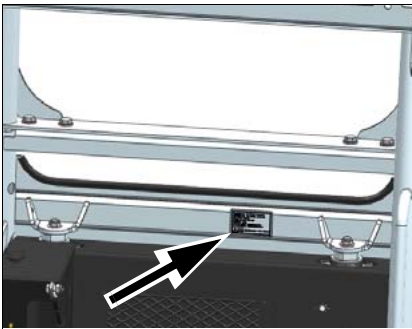

Fig. 5 (Symbolic representation)

### Canopy number

The type label is located at the rear of the canopy.

Warning labels

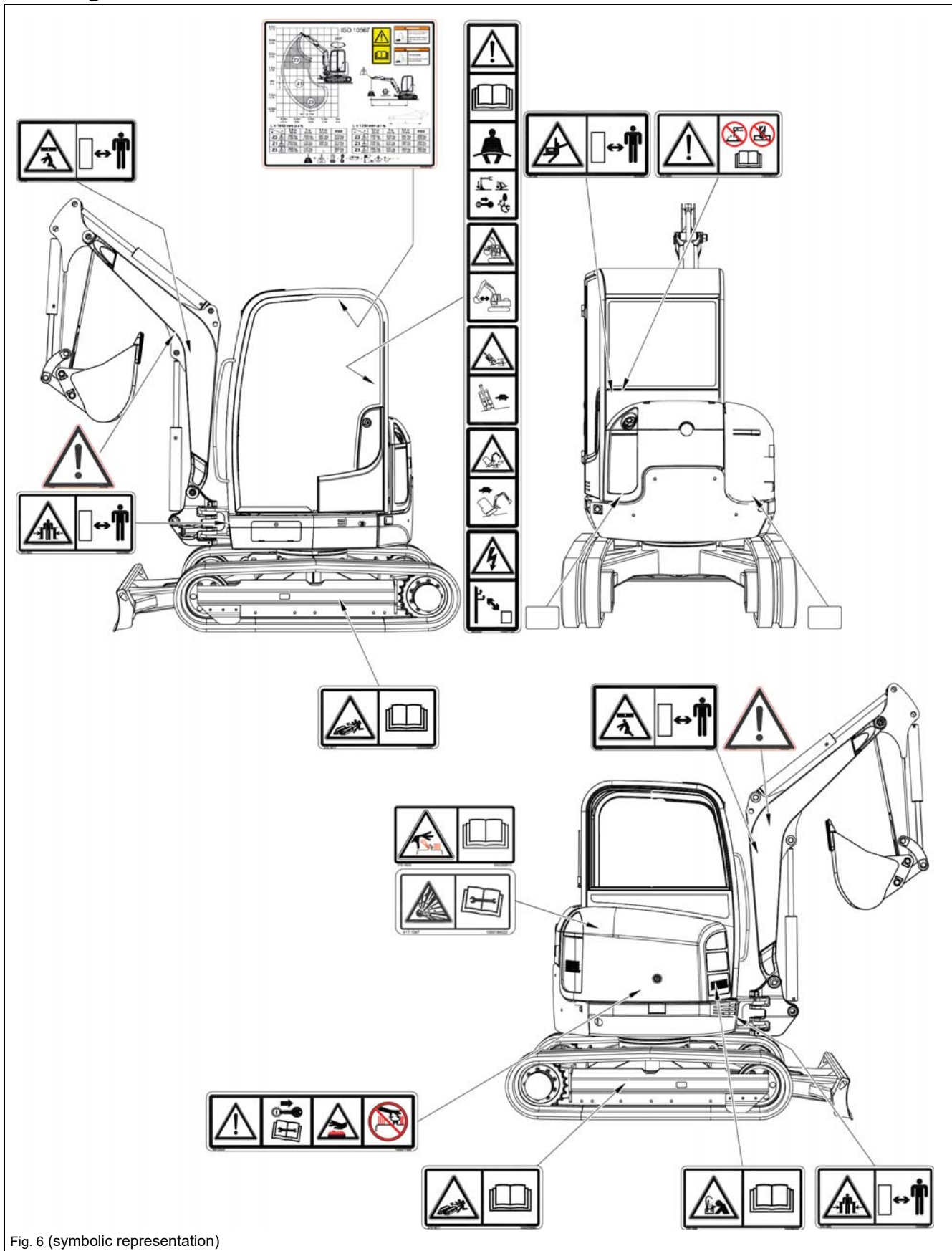

Fig. 6 (symbolic representation)



Fig. 7

**Meaning**

Crush Hazard

All persons must stay clear of a raised load or of the danger zone.

**Position**

On the left and right side on the lifting arm.



Fig. 8

**Meaning**

Crush Hazard

Do not allow anyone to stay in the danger zone of the vehicle.

**Position**

At the front left and right of the chassis

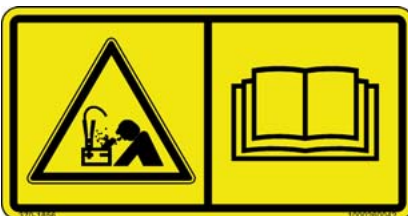

Fig. 9

**Meaning**

Explosion hazard due to wrong connection of battery jump cables

**Position**

Next to the battery



Fig. 10

**Meaning**

Crush Hazard

Do not allow anyone to stay in the swiveling range of the vehicle.

**Position**

On the rear left of the cabin



Fig. 11

**Meaning**

Modifications to the structure (for example welding, drilling), retrofitting, and incorrect repairs affect the protective effect of the cabin and can cause serious injury and even death.

**Position**

On the rear left of the cabin



Fig. 12

**Meaning**

Accumulator is under high pressure. Maintenance or repair work may be performed only by a Wacker Neuson service center.

**Position**

On the fuse box



Fig. 13

**Meaning**

Release the pressure in the hydraulic system.

Read Operator's Manual.

**Position**

In the engine compartment



Fig. 14

**Meaning**

Injury hazard due to grease escaping under pressure

Read the operator's manual before working with the track tensioner.

**Position**

On left and right-hand undercarriage



Fig. 15

**Meaning**

Read the Operator's Manual before starting the vehicle.

Remove the starting key and carry it with you.

Injury hazard due to rotating parts.

- Open the engine cover only at engine standstill.

Burn hazard due to hot surfaces

- Let the engine cool down.

Burn hazard due to hot fluid

Injury hazard due to fluid escaping under pressure

- Let the engine cool down.
- Release the pressure in the hydraulic system, then open the locks carefully.

**Position**

On the engine cover



Fig. 16

**Meaning**

Burn hazard due to hot surfaces (lines, plug connections, hardware, hydraulic cylinders, couplings, etc.)

**Position**

On the boom on the left and right

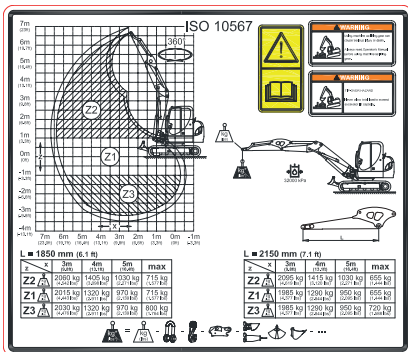

Fig. 17 (symbolic representation)

**Meaning**

Load diagram

**Position**

On the headliner





Fig. 18

**Meaning**

Read the Operator's Manual before starting the vehicle.

Fasten your seat belt.

Lower the boom and the stabilizer blade to the ground.

Remove the starting key and carry it with you.

Raise the control lever base.

**Crush Hazard**

Possible serious vehicle damage.

Keep a safe distance from the cabin.

**Crush Hazard**

Possible serious vehicle damage.

During vehicle operation on slopes, pay attention to the maximum gradient angle and maximum lateral angle of inclination.

Do not drive in speed range 2.

**Risk of fatal injuries due to electric shock**

During vehicle operation, maintain a safe distance from overhead electric lines.

**Position**

On the C pillar on the right



Fig. 19

**Meaning**

Switch on the safe load indicator during lifting gear applications.

A vehicle can cause serious injury or death if it tips over.

Possible serious vehicle damage

Read and understand the Operator's Manual.

**Position**

On the B pillar on the left

Information labels

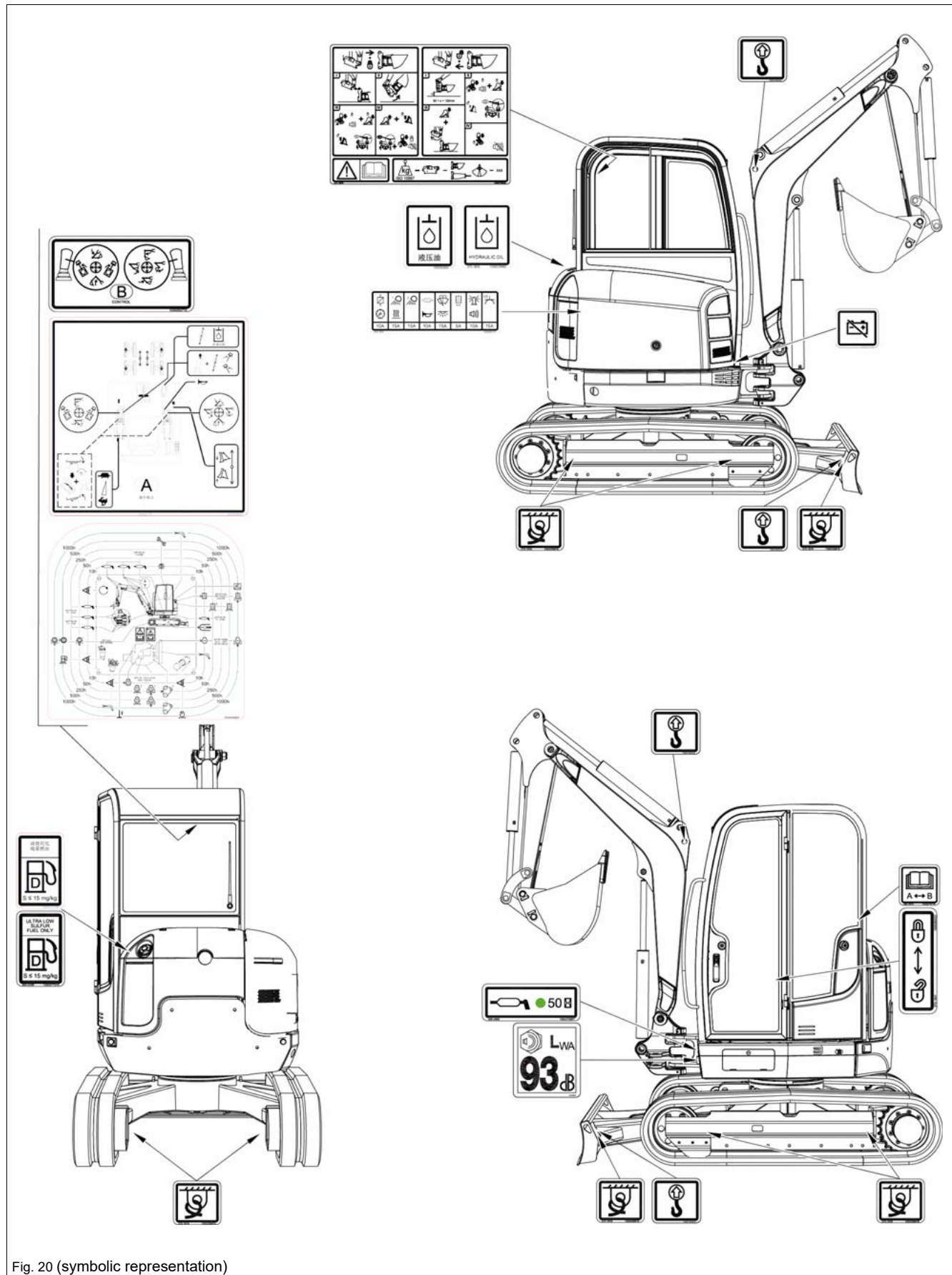

Fig. 20 (symbolic representation)



Fig. 21

**Meaning**

Only refuel with diesel fuel with a sulfur content of < 15 mg/kg (= 0.0015%).

**Position**

Next to the fuel tank filler inlet



Fig. 22

**Meaning**

Hydraulic oil

**Position**

Next to the filler neck of the hydraulic oil tank



Fig. 23

**Meaning**

Lifting eyes

**Position**

Boom: left and right side, near lifting eye

Dozer blade: left and right on lifting eyes



Fig. 24

**Meaning**

Tie-down points

**Position**

Dozer blade: left and right

Travel gear: left and right at the front, left and right at the back, left and right on the inside

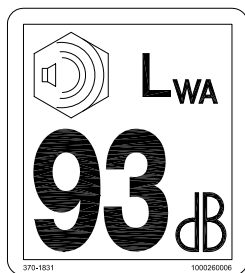

Fig. 25 (symbolic representation)

**Meaning**

Indication of sound power level produced by the vehicle.

$L_{WA}$  = sound power level

**Position**

At the front left of the chassis

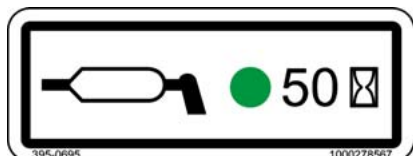

Fig. 26

**Meaning**

Lubrication interval

**Position**

At the front left of the chassis



Fig. 27:

**Meaning**

VDS lubrication points

**Position**

On the roof window on right in travel direction

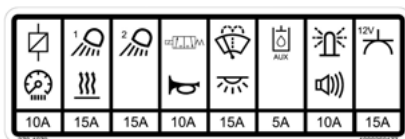

Fig. 28: Fuse box

**Meaning**

Fuses

**Position**

On the fuse box

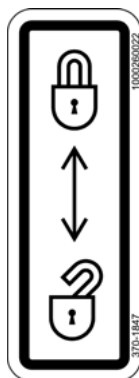

Fig. 29

**Meaning**

Hydraulic functions active or locked

**Position**

On control lever base



Fig. 30

**Meaning**

Check before starting the machine the operating pattern that has been chosen.

Wiring diagram	Controls
A	ISO controls
B	SAE controls

**Position**

Behind the seat on the left

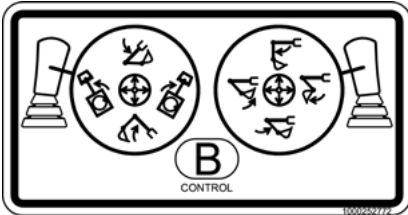

Fig. 31

**Meaning**

Operating procedures differing from the ISO controls if the SAE controls are set.

**Position**

On the roof window



Fig. 32

**Meaning**

Battery master switch

**Position**

Next to the battery

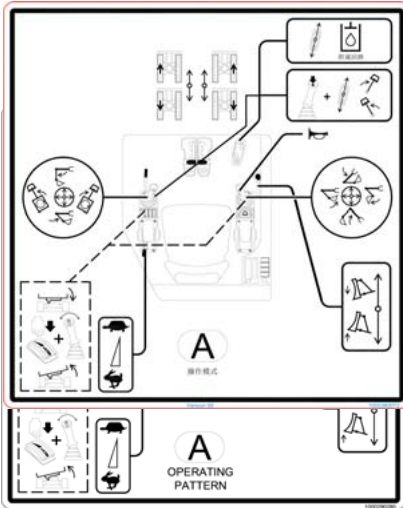

Fig. 33

**Meaning**

Functional overview (ISO controls).

Check the selected control mode before starting the vehicle.

**Position**

On the roof window

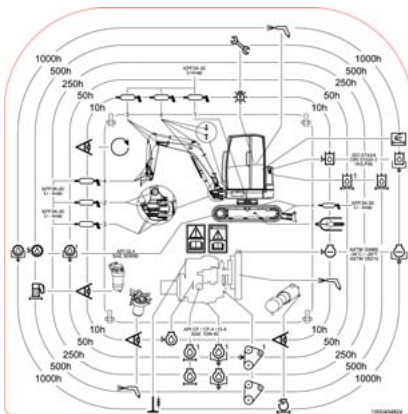

Fig. 34 (symbolic representation)

**Meaning**

Maintenance intervals

**Position**

On the roof window

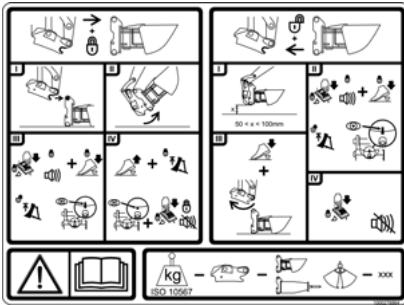

**Meaning**

Hydraulic quickhitch

**Position**

On the roof window

Fig. 35

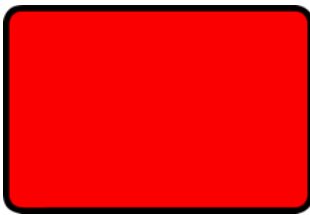

Fig. 36

**Meaning**

Reflectors

**Position**

At the rear left and right of the vehicle



**Information**

Type, quantity, and position of the labels depend on options, country and vehicle.



Notes:



## 4 Putting into operation

### 4.1 Cab

---

 **CAUTION****Injury hazard when getting on and off!**

Entering or exiting incorrectly can cause injury.

- ▶ Keep the mandatory stages and handhold clean and only use them for entering and exiting.
  - ▶ Two hands and one foot must be always in contact with the vehicle when getting on and off
  - ▶ Face the vehicle as you enter and leave it.
  - ▶ Have damaged stages and handles replaced. Do not operate the vehicle.
- 

 **CAUTION****Crushing hazard due to incorrectly locked door!**

Unlocked cabin doors can cause crushing.

- ▶ When entering or leaving the cabin, the door must be locked in the arrester.
  - ▶ Use the handholds for closing.
- 

 **CAUTION****Injury hazard when opening or closing the front window!**

Opening or closing the front window can cause injury.

- ▶ Use both handles.
  - ▶ Duck your head.
  - ▶ Let both locks lock into place.
  - ▶ Keep the window channel clear.
-

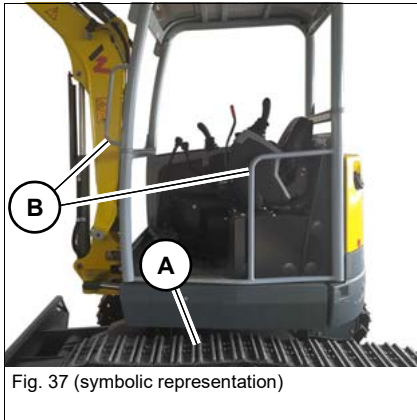

### Getting on and off

Use only footholds **A** and handles **B** when getting on and off. Do not support yourself on the control elements.

### Unlocking and locking the door

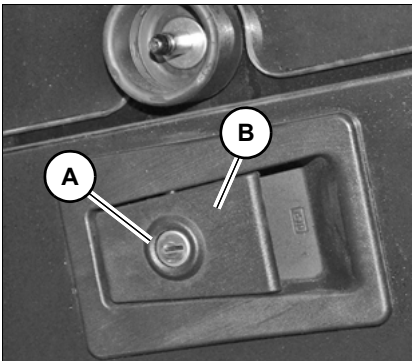

Fig. 38

**Unlocking:**

Turn the key in door lock **A** anticlockwise.

**Locking:**

Turn the key in door lock **A** clockwise.

### Opening and closing the door

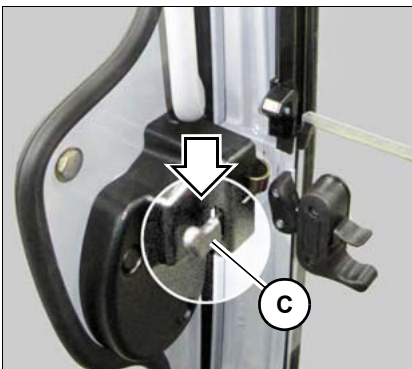

Fig. 39 (symbolic representation)

**Opening:**

Pull door handle **B**.

**Closing:**

Close the door applying firm pressure.

**Opening the door from the inside:**

Press lever **C** on the door lock downward.

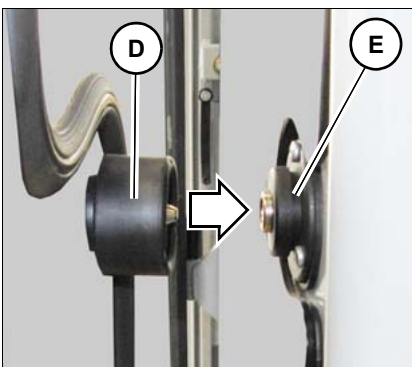

Fig. 40 (symbolic representation)

**Securing an open door**

Press bracket **D** firmly against door arrester **E**.

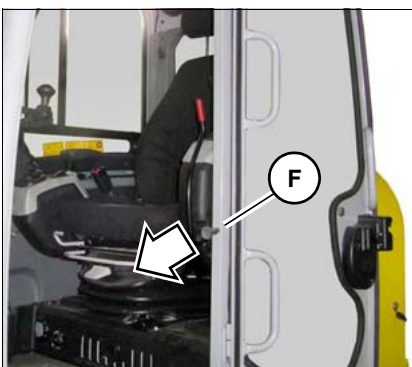

Fig. 41

**Releasing the door arrester**

Pull button **F**.

### Opening/closing the front window



#### Opening the upper front window

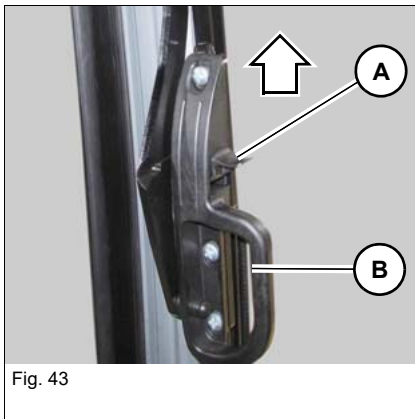

1. Press and hold levers **A** on the left and right, and pull the front window forward with handles **B** on the left and right.
2. Release levers **A** and press the window upward until it engages.

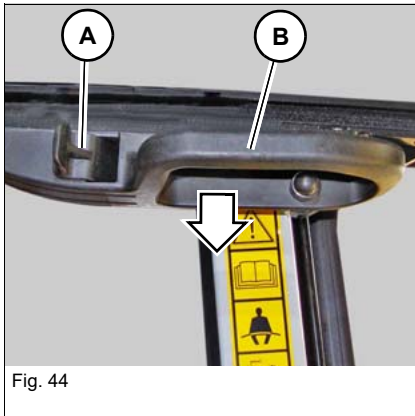

#### Closing the upper front window

1. Press levers **A** on the left and right, and pull the front window downward with handles **B** on the left and right.
2. Press the front window fully forward and release levers **A**.



### Opening the lower front window

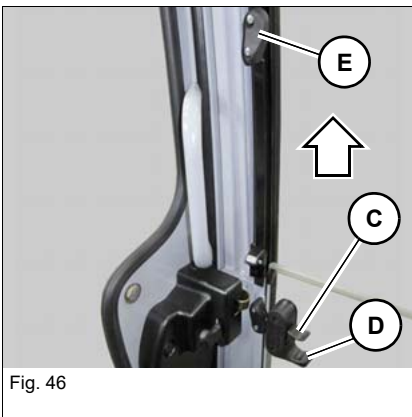

Press levers **C** on the left and right, and pull the front window upward with handles **D** on the left and right until the front window engages with guide **E**.

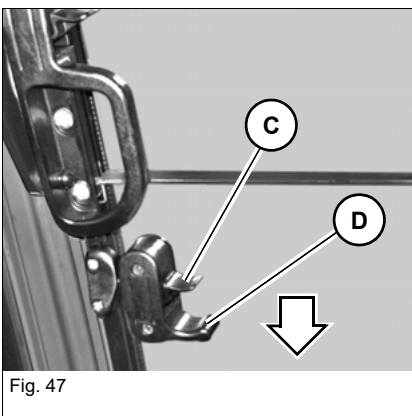

### Closing the lower front window

Keep levers **C** pressed on the left and right, and pull the lower front window downward with handles **D** until the front window engages.



Fig. 48

### Opening the whole front window

1. Open the lower front window as described on page 4-5.
2. Open both windows together as described on page 4-4.

### Closing the whole front window

1. Close both windows together as described on page 4-4.
2. Close the lower front window as described 4-5 on page.

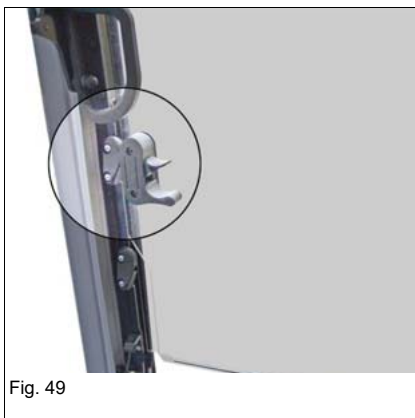

Fig. 49

---

### NOTICE

If the protective Front Guard structure is installed, the front windows can be damaged.

- ▶ The lower front window must be fully open when the entire front window is opened or closed (*Fig. 49*).
- 



Fig. 50

### Opening the front window to a gap (ventilation position)

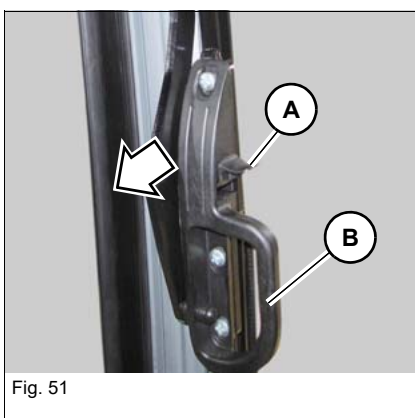

Fig. 51

1. Press levers **A** on the left and right, and slightly pull handles **B** on the left and right.
  - The front window is unlocked.
2. Release levers **A** and pull handles **B** on the left and right until the front window engages.

## Opening/closing the side windows

Both side windows on the right can be opened.

### Open

Press the handle **A** and open the side window.

### Close

Press the handle **A** and close the side window.

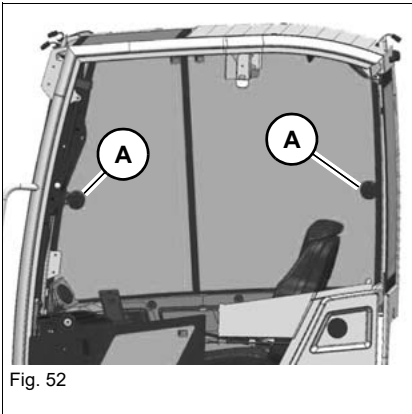

Fig. 52

### Emergency exit

There are several possibilities for an emergency exit:

- Front Guard not installed: front or right window
- Front Guard installed: rear window or right window

---

#### **WARNING**

##### **Injury hazard when leaving the cabin in an emergency!**

An emergency exit can cause serious injury or death.

- ▶ The front and the right of the vehicle have neither footholds nor handles for safely exiting the cabin.

---

### Emergency exit on vehicles equipped with protective Front Guard structures

---

#### **WARNING**

##### **Injury hazard when leaving the cabin in an emergency!**

An emergency exit can cause serious injury or death.

- ▶ There are no footholds nor handles for safely exiting the cabin at the rear and the right side of the vehicle.
- ▶ Protect your face and eyes from the glass splinters flying around when you smash a window.
- ▶ Pay attention to glass splinters during an emergency exit.

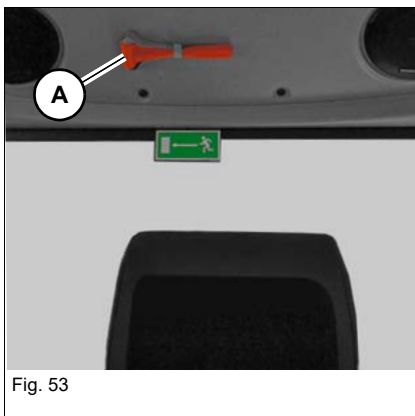

The rear or right windows can be used as an emergency exit if the cabin door or front windows are blocked.

Smash the rear window with emergency hammer **A** above the rear window.



## Comfort seat

---

 **WARNING****Danger of accident due to seat adjustment during vehicle operation!**

Adjusting the seat during vehicle operation can cause serious injury or death.

- ▶ Adjust the seat before putting the machine into operation.
  - ▶ Ensure that the levers are locked into place.
- 

---

 **CAUTION****Spinal cord injury due to incorrect seat adjustment!**

An incorrect weight adjustment can cause injury to the spinal cord.

- ▶ Ensure that the seat is correctly adjusted to the operator's weight before vehicle travel or operation.
-

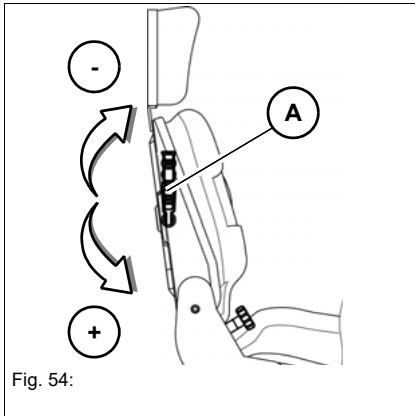

### Weight

1. Sit down on the operator seat.
2. Turn lever **A** counterclockwise.
  - Adjusts a higher weight.
3. Turn lever **A** clockwise.
  - Adjusts a lower weight.

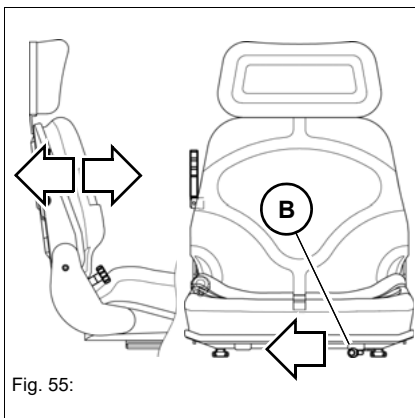

### Length

1. Sit down on the operator seat.
2. Move and hold lever **B** as far as it will go in the direction of the arrow.
3. Move and engage the seat in the required position.
4. Return lever **B** to the initial position.

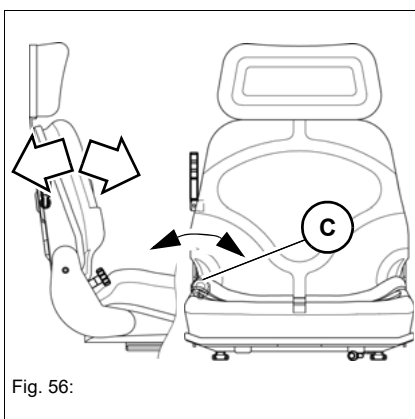

### Backrest

1. Sit down on the operator seat.
2. Turn lever **C** counterclockwise.
  - The backrest moves forward.
3. Turn lever **C** clockwise.
  - The backrest moves backward.

## Adjusting the seat belt

---

 **WARNING****Injury hazard if the seat belt is not fastened correctly or not at all!**

Fastening the seat belt incorrectly, or not at all, can cause serious injury or death.

- ▶ Firmly fasten your seat belt over your hips before starting the engine.
  - ▶ Do not unfasten the seat belt when the engine is running. This applies to work interruptions as well.
  - ▶ Do not fasten a twisted seat belt, and do not place it over hard, edged or fragile items in your clothes.
  - ▶ Ensure that the buckle is inserted.
- 

---

 **CAUTION****Injury hazard due to damaged or dirty seat belt!**

A damaged or dirty seat belt can cause serious injury or death.

- ▶ Keep the seat belt and buckle clean, and check them for damage.
  - ▶ Have a damaged seat belt and buckle immediately replaced by an authorized service center.
  - ▶ Have the seat belt immediately replaced after every accident and the load-bearing capacity of the fastening points and seat fixtures checked by a Wacker Neuson service center.
-

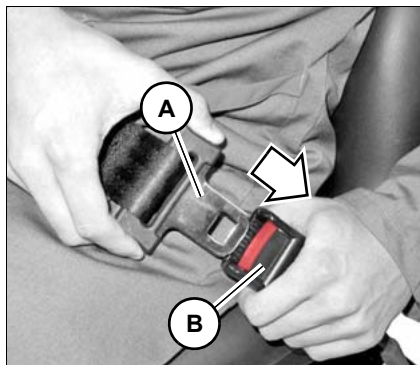

Fig. 57

### Fasten seat belt

Insert buckle latch **A** into seat belt buckle **B** until it engages.

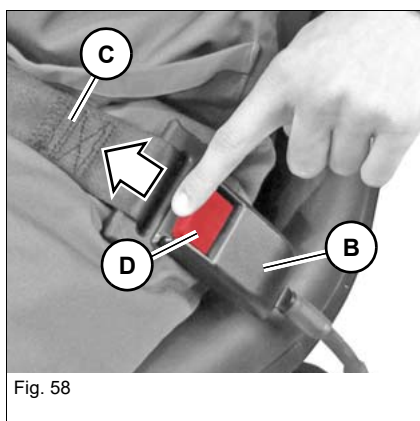

Fig. 58

### Release seat belt

Press the red touch button **D** on the buckle **B** until the buckle latch comes out.

➔ Seat belt **C** is automatically retracted.

## Visual aids

---

 **WARNING****Risk of injury to persons in the danger zone!**

Persons in the danger area are possibly not seen when reversing the vehicle and this can cause accidents with serious injuries or death.

- ▶ Adjust the existing visual aids (for example the rearview mirrors) correctly.
  - ▶ Interrupt work immediately if persons enter the danger zone.
  - ▶ Pay attention to the movements and changing positions of attachments and persons.
- 

---

 **WARNING****Accident hazard due to restricted field of vision on the job site!**

Accidents resulting in serious injury or death can be caused by a restricted field of vision.

- ▶ Do not allow anyone to stay in the danger zone.
  - ▶ Use suitable visual aids if necessary (for example a camera, mirrors, guide).
  - ▶ Additional equipment or attachments must not be installed if they impair visibility.
- 

---

 **WARNING****Accident hazard due to incorrect adjustment of visual aids!**

Incorrectly adjusted visual aids can cause serious injury or death.

- ▶ Before starting work, ensure that all visual aids are clean, functional and adjusted in accordance with the instructions in this Operator's Manual.
  - ▶ Immediately replace damaged or broken visual aids.
  - ▶ Convex mirrors enlarge, reduce or distort the field of view.
  - ▶ The operator must follow the national and regional regulations.
-

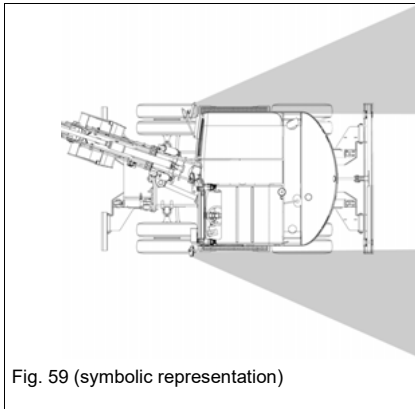

### Adjusting the outside rear-view mirrors on left and right

- Ensure sufficient visibility from the seat of the work areasite.
- Ensure maximum visibility to the rear.
- Ensure visibility of the rear left edge of the vehicle in the mirror on the left.
- Ensure visibility of the rear right edge of the vehicle in the mirror on the right.

---

#### **i** Information

Wacker Neuson recommends adjusting the mirrors with two persons.

---

#### **i** Information

Do not make any modifications that impair visibility. Otherwise the vehicle does not meet the requirements for conformity and registration.

---

- Use safety-oriented ladders and work platforms for adjustment work on the vehicle.
- Do not use vehicle parts or attachments as a climbing aid.
- Set the boom to travel position before adjusting the mirrors.

## Armrest

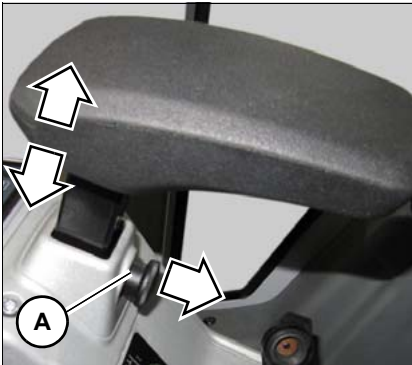

Fig. 60 (symbolic representation)

1. Hold the armrest and pull out button **A**.
2. Adjust the armrest height.
3. Release button **A**.

## Fire extinguisher

A fire extinguisher is not available from Wacker Neuson.

Contact a Wacker Neuson service center for the installation of a fire extinguisher.

Wacker Neuson recommends a fire extinguisher of the class ABC, e. g. according to DIN-EN 3, NFPA. Comply with national provisions.



### **CAUTION**

#### **Risk of injury from non-secured fire extinguisher!**

Can cause injury.

- ▶ Check fire extinguisher and its mounting daily.
- ▶ Comply with manufacturer's specifications and test intervals.

### Protective structures

Protective structures are additional elements that protect the operator against dangers. These elements can be installed later on or as standard equipment.

---

#### **DANGER**

##### **Accident hazard due to modified cabin or protective structures!**

Modifications (for example drilling) weaken the structure and causes serious injury or death.

- ▶ No drilling, cutting or grinding.
- ▶ Do not install any brackets.
- ▶ No welding, straightening or bending.
- ▶ Replace the complete protective structure if it is damaged, deformed or cracked.
- ▶ Contact a Wacker Neuson service center in case of doubt.
- ▶ Retrofit and repair work may only be performed by a Wacker Neuson service center.
- ▶ Replace self-locking fasteners.

---

#### **Information**

Machine operation is only allowed with a correctly attached and intact cabin.

For additional protection, only use correctly installed and intact Wacker Neuson protective structures that have been released for the vehicle.

---

#### **Responsibility for vehicle equipped with protective structures**

The decision regarding the necessary protective structures (type and level I or II) must be made by the vehicle owner and depends on the specific work situation.

The vehicle owner must observe the national regulations and he must inform the operator on the protective structure to be used in a specific work situation.



## Assembly

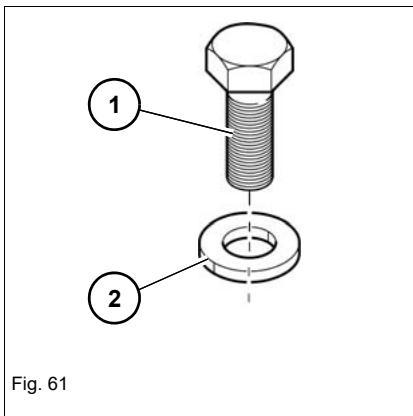

Fig. 61

The term **screw** is used for fastening equipment used in the following sequence:

1. Screw
2. Washer



### Information

Only install protective structures with the help of a crane.

## Protective Front Guard structure category I (cab option)



### DANGER

**Danger of piercing/penetration by objects from the front!**

Causes serious injury or death.

- ▶ Install a protective Front Guard structure in areas with danger from the front.
- ▶ The vehicle owner must ensure that the hazard situation is evaluated and that the national regulations are observed.
- ▶ The vehicle owner must ensure that only work is performed that does not require any higher protection.



### Information

The protective Front Guard structure corresponds to category I according to ISO 10262:1998.

- ▶ Accidents cannot be fully avoided despite equipping a vehicle with protective structures.

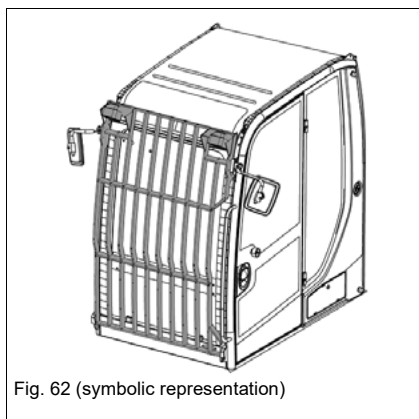

1. Stop and park the vehicle. Stop the engine See "Preparing lubrication"

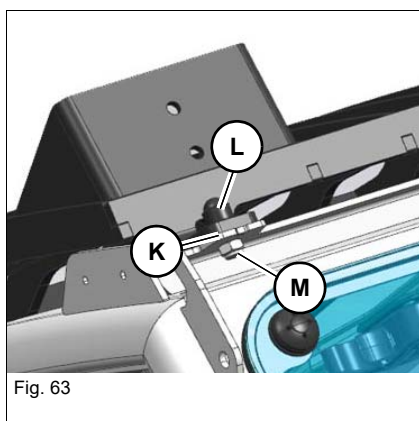

**K**: mounting points top left and right.

2. Install screws **L** and lock nuts **M** and tighten to 110 Nm (81 ft.lbs.).

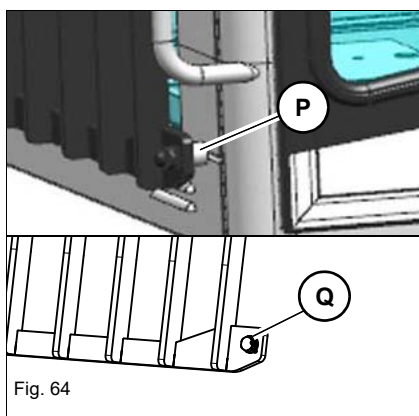

**P**: mounting points bottom left and right.

3. Install screws **Q** and tighten to 110 Nm (81 ft.lbs.).

Put caps on all screws and nuts.

## Shatter protection

---

 **WARNING****Danger of piercing/penetration by objects from the front!**

Work involving risk of piercing/penetrating by objects from the front can cause accidents with serious injury or death.

- ▶ To operate the vehicle, shatter protection must be installed if an attachment (a breaker, for example) causes fragments to fly around. This shatter protection takes over the function of a front window. If the machine is equipped with a cab, the front window must be closed during hammer operation.
- ▶ The vehicle owner must ensure that the hazard situation is evaluated and that the national regulations are observed.
- ▶ The vehicle owner must ensure that only work is performed that does not require any higher protection.
- ▶ Observe the prescribed work area - see [Job site](#).

---

 **WARNING****Danger of accident with restricted visibility!**

Restricted visibility (e.g. weather influences, dust, improper cleaning) can cause serious injury or death.

- ▶ Stop machine operation immediately.
- ▶ Do not use brushes, steel wool or other abrasive cleaners for cleaning the polycarbonate disk. Do not wipe dust in a dry state.

---

**NOTICE**

Possible damage to the vehicle structure from improper assembly.

- ▶ Only an authorized service center may install the shatter protection for the first time.

---

 **Information**

The shatter protection protects the user against penetrating fragments from the front.

- ▶ Accidents cannot be fully avoided despite equipping a vehicle with protective structures.
-

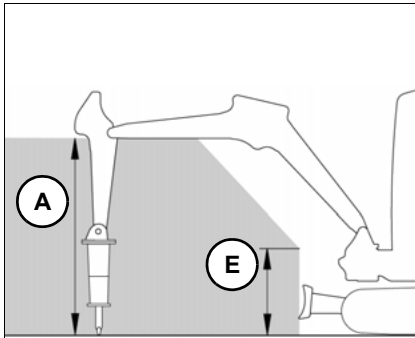

Fig. 65 (symbolic representation)

### Job site

Work range height **A**: 120 cm (47 in), **E**: 50 cm (20 in).

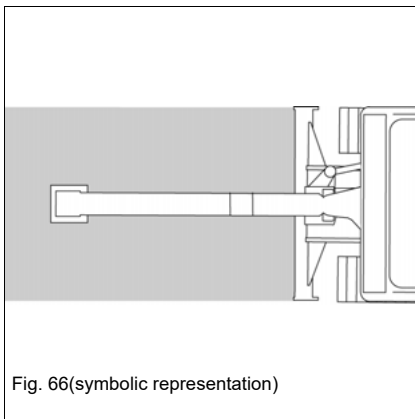

Fig. 66(symbolic representation)

Figures 65 and 66 refer to work with a Wacker Neuson hydraulic hammer.



### Information

Working with another attachment can modify the height of the job site.



### Installing the shatter protection

At least two people are required for the assembly or disassembly.

Preparations – see chapter “*Parking the vehicle*” on page 5-9

1. Install the mounting angle **A** with screws **B** on the shatter protection **C**.
2. Install the shatter protection with screws **D** to the frame.

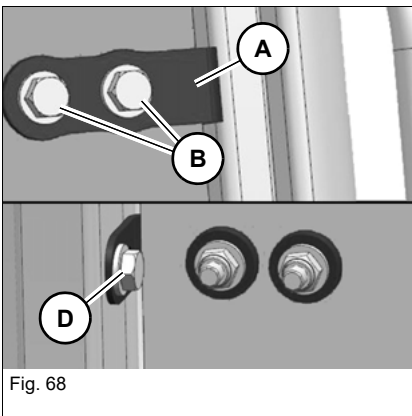

---

### Information

Torque for screws and nuts: 25 Nm (18 ft.lbs)

---

### Removing the shatter protection

1. Loosen screws **D** and remove shatter protection.
2. Install the screws **D** on the frame to prevent the entry of moisture. Securely store the shatter protection.

### Document box

A document box behind the seat is available as an option.

### 12 V connection



Fig. 69



Fig. 70



Fig. 71

12V connections are located at the rear right in the connection, left front on the chassis and at the back on the cab roof.



## **4.2 Overview of control elements**

This chapter describes the controls, and contains information on the function and handling of the indicator lights and controls in the cab.

The pages stated in the table refer to the description of the controls.

Cabin

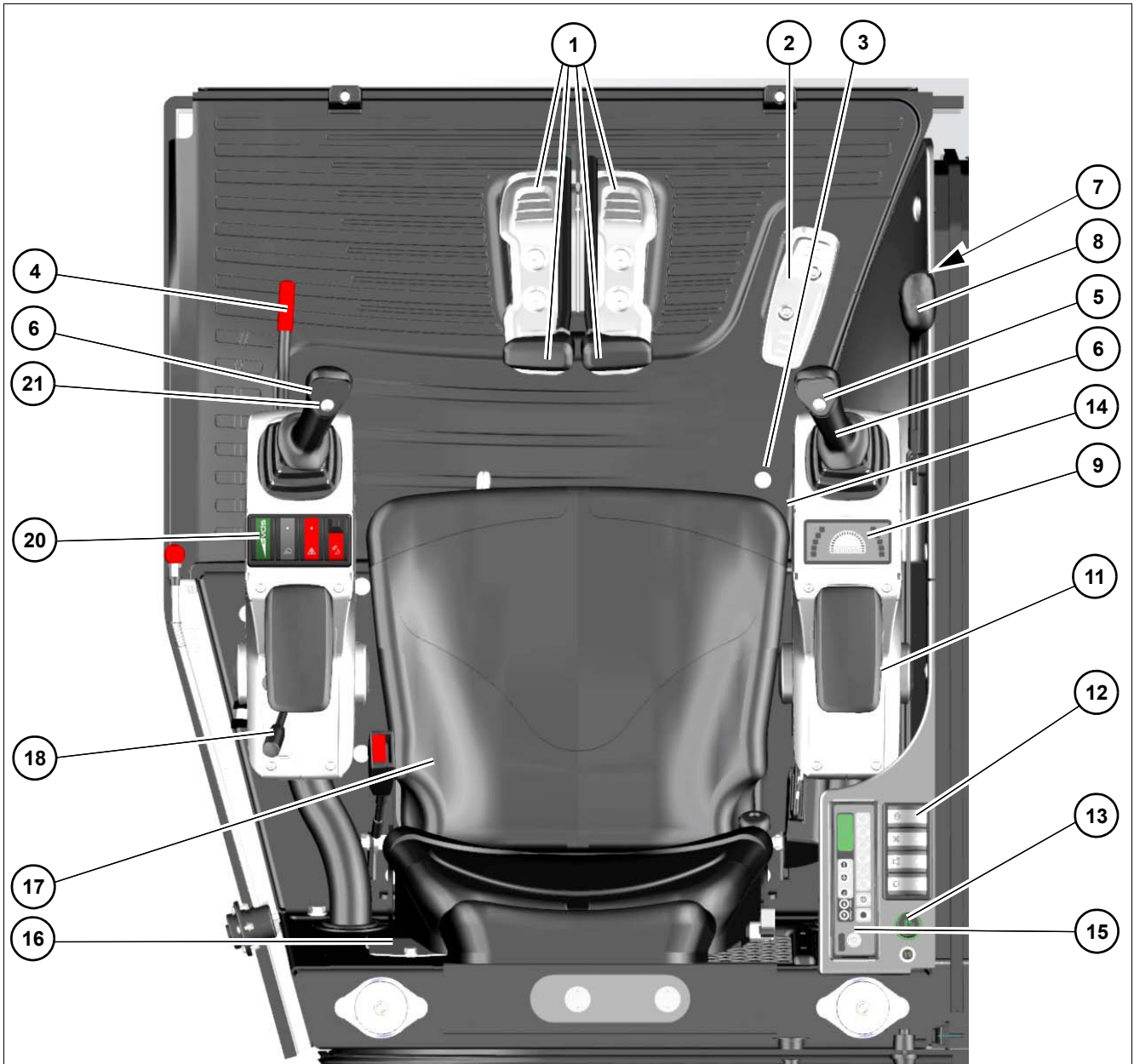

Fig. 72:

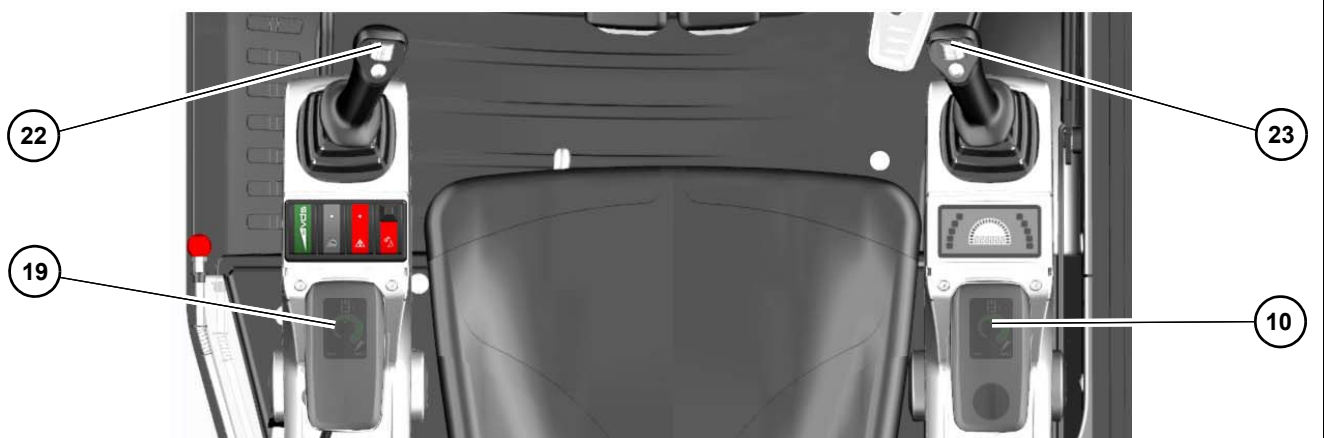
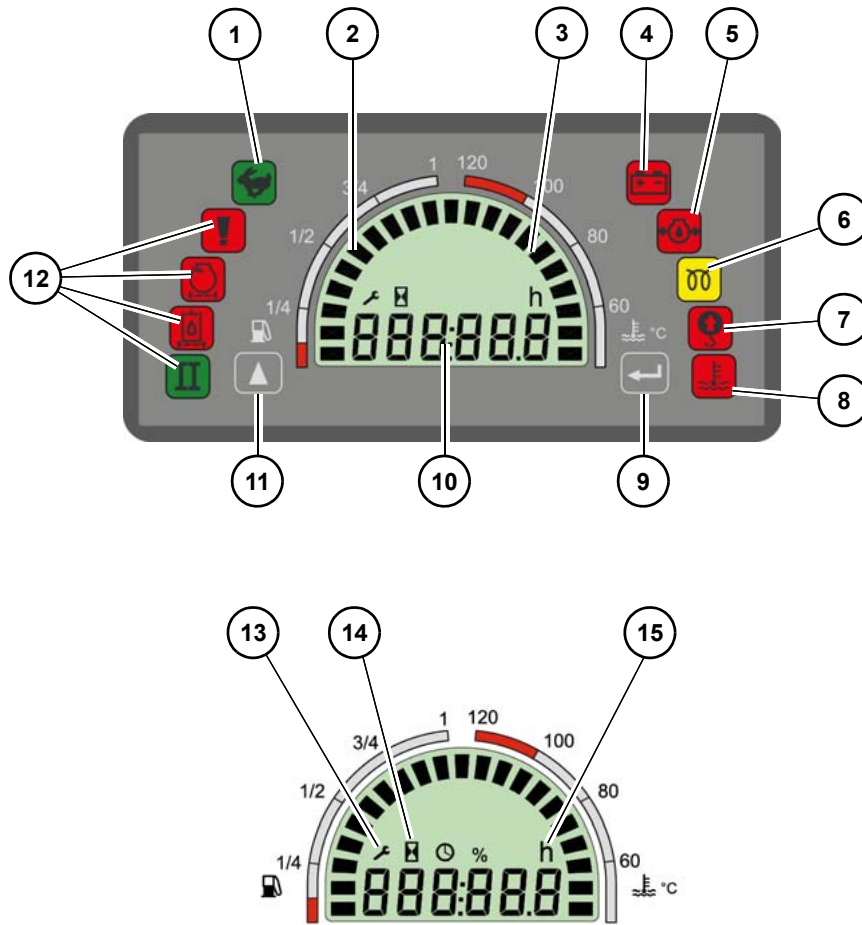

Fig. 72:



<b>Designation</b>	<b>See page</b>
1. Accelerator pedals/drive levers	<a href="#">5-1</a>
2. Boom swivel pedal (AUX I)	<a href="#">5-17, 5-25</a>
3. Foot-operated push button for hydraulic quickhitch	<a href="#">5-27</a>
4. Control lever base	<a href="#">4-37</a>
5. Horn	<a href="#">5-11</a>
6. Control levers	<a href="#">5-15</a>
7. Speed range selection	<a href="#">5-2</a>
8. Stabilizer-blade lever	<a href="#">5-21</a>
9. Display element	<a href="#">4-26</a>
10. Oil flow AUX I rotary switch (proportional controls)	<a href="#">5-25</a>
11. Ignition lock	<a href="#">4-36</a>
12. Switch panel (right)	<a href="#">4-26</a>
13. 12 V connection	--
14. Temperature controller	<a href="#">5-14</a>
15. Radio	--
16. ISO/SAE changeover	<a href="#">5-16</a>
17. Seat	<a href="#">4-9</a>
18. Throttle	<a href="#">5-2</a>
19. Oil flow AUX II rotary switch (proportional controls)	<a href="#">5-25</a>
20. Left-hand switch panel	<a href="#">4-26</a>
21. Boom swivel pedal changeover/AUX I	--
22. Operation of AUX II or AUX I (proportional controls/option)	<a href="#">5-25</a>
23. Operation of AUX I (proportional controls/option)	<a href="#">5-25</a>

Display element and switches



Right switch panel

Left-hand switch panel

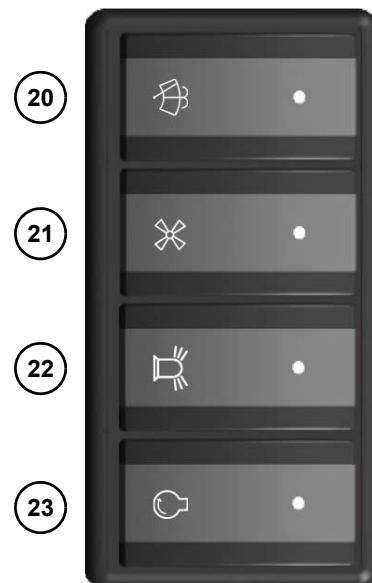

Fig. 73:

<b>Designation</b>	<b>See page</b>
1. Speed range 2	<a href="#">5-2</a>
2. Fuel level indicator	<a href="#">4-30</a>
3. Coolant temperature	<a href="#">4-29</a>
4. Charge indicator light	<a href="#">4-29</a>
5. Engine oil pressure	<a href="#">4-29</a>
6. Preheating	<a href="#">4-36</a>
7. Safe load indicator light	<a href="#">4-30</a>
8. Coolant temperature	<a href="#">4-29</a>
9. For Wacker Neuson service center only	--
10. Hour meter/maintenance meter	<a href="#">4-30</a>
11. Hour meter/maintenance meter changeover	<a href="#">4-30</a>
12. Not assigned	--
13. Maintenance meter	<a href="#">4-30</a>
14. Operating hours	<a href="#">4-30</a>
15. Daily hours of operation	--
16. Tilt the upper carriage (VDS/option)	<a href="#">5-59</a>
17. Working lights	<a href="#">5-11</a>
18. Safe load indicator	<a href="#">5-45</a>
19. Hydraulic quickhitch	<a href="#">5-27</a>
20. Wiper/wash system	<a href="#">5-13</a>
21. Fan	<a href="#">5-14</a>
22. Rotating beacon	<a href="#">5-12</a>
23. Automatic engine speed setting	<a href="#">5-3</a>

### 4.3 Control and warning lights overview

#### Display element

The display element informs the operator about operating states, required maintenance procedures and possible vehicle malfunctions.

---



#### **Information**

It may take a few seconds before a selected function is displayed.

---











#### **Information**

The indicator lights are tested when the starter is engaged and are illuminated for a few seconds.

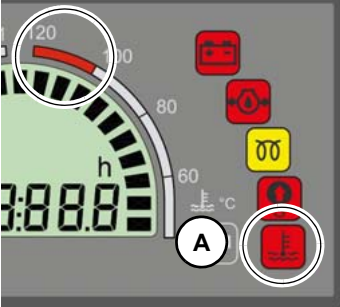
---

**Status indicators**

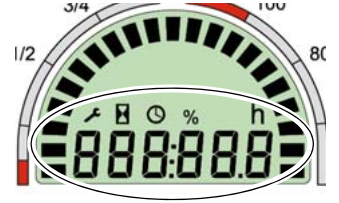
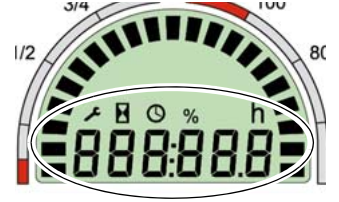
Symbol	
	<p><b>Speed range 2</b></p> <p>The control lamp (green) lights up if the speed 2 is active.</p>
	<p><b>Charge indicator light</b></p> <p>This indicator light (red) illuminates if the electrical system has a malfunction. The battery is no longer or insufficiently charged.</p> <p><b>Note:</b> This indicator light also illuminates if the starting key is turned to position 2. The indicator light goes out after the engine is started.</p> <p>Increase engine speed if the indicator light illuminates. The electrical system works if the indicator light of the electrical system goes out within one minute.</p>
	<p><b>Engine oil pressure</b></p> <p>The indicator light (red) illuminates and the buzzer sounds.</p> <ul style="list-style-type: none"> <li>• Stop the engine immediately and check the engine oil level.</li> <li>• If the engine oil level is correct, contact a Wacker Neuson service center.</li> </ul> <p><b>Note:</b> The indicator light illuminates when the starter is turned on and goes out as soon as the engine runs.</p> <p>At low temperatures, the indicator light can illuminate a few seconds after the engine is started.</p>
	<p><b>Preheating</b></p> <p>The indicator light (yellow) illuminates if the starting key is in position 2. Contact an authorized service center if the indicator light does not go out after 20 seconds.</p>
	<p><b>Overload</b></p> <p>The indicator light illuminates red and the buzzer sounds.</p> <p>The permissible load diagram values are exceeded.</p> <ul style="list-style-type: none"> <li>• Reduce the load until both the buzzer and the warning light go out – <a href="#">see chapter “Lifting gear applications” on page 5-44.</a></li> </ul> <p>When the safe load indicator is switched on, the symbol is illuminated and the buzzer sounds as a functional check.</p>
	<p><b>Coolant temperature</b></p> <p>If the segments reach the red range, the indicator light <b>A</b> illuminates and the buzzer sounds.</p> <p><b>Measures to be taken</b></p> <ul style="list-style-type: none"> <li>• Let the engine run at high idling speed without any load.</li> <li>• Wait until the temperature drops and the indicator light goes out.</li> <li>• Stop the engine</li> <li>• Check the coolant level.</li> </ul>

Symbol	
	<p><b>Fuel tank capacity</b> Refuel if the segments reach the red range.</p>
	<p><b>Hour meter</b> Counts the engine operating hours with the engine running.</p>
	<p><b>Maintenance meter</b> Counts the remaining engine operating hours down to the next maintenance work due. If less than 10 hours are displayed, the wrench symbol flashes.</p>
	<p><b>Overload</b> The symbol shown on the left appears and the buzzer sounds. The permissible load diagram values are exceeded.</p> <ul style="list-style-type: none"> <li>Reduce the load until both the buzzer and the warning light go out – <a href="#">see chapter “Lifting gear applications” on page 5-44.</a></li> </ul> <p>When the safe load indicator is switched on, the symbol is illuminated and the buzzer sounds as a functional check.</p>
	<p>Switch-over between <b>the operating hour meter</b> and <b>the</b> maintenance counter</p>

## 4.4 Preparatory work

### Important information before putting the vehicle into operation

Perform a visual check before starting work:

- There must be no leaks.
- There must be no damaged or loose parts.
- Do not allow anyone to stay in the danger zone.

Before putting the machine into operation, the operator must familiarize himself with the position of the controls and instruments.

Only operate the vehicle from the seat with the seat belt fastened.

Before using the vehicle in work operation for the first time, Wacker Neuson recommends trying out the vehicle on open ground without any obstacles.

When using the vehicle, check the surroundings constantly in order to identify potential hazards in time.

Before starting work, ensure that all visual aids are clean, functional and adjusted in accordance with the instructions in this Operator's Manual.

The operator must follow the national and regional regulations.

Perform a **functional check of the control lever base**.

Perform a **functional check of the safe load indicator**.

Do not make any modifications that impair visibility. The vehicle does not meet the requirements for conformity and registration.

Observe the safety instructions – [see chapter "2.4 Operation" on page 2-4](#).

### Requirements and information for the operating personnel

Read, understand and follow this Operator's Manual and all other Operator's Manuals supplied with the vehicle.

The vehicle may only be put into operation by authorized personnel that has been instructed – [see chapter "2.3 Conduct" on page 2-3](#).

The operator must know and adhere to the requirements and risks at the workplace.

Perform daily maintenance according to the Lubrication and maintenance plan (see chapter "**Maintenance 7.2**")

Face the vehicle as you enter and exit it, and only use the mandatory climbing aids for entering and exiting.

Keep the footholds and the handholds clean to ensure a safe hold at all times. Immediately remove dirt, oil, snow, etc.

Do not get on a moving vehicle, or jump off it.

Do not operate the vehicle if the standard protective equipment (for example the cabin) has been removed.

No clothes or parts of the body may protrude outside the vehicle during operation.

### Check lists

The checklists below assist you in checking and monitoring the vehicle before, during, and after operation.

Wacker Neuson does not claim those lists to be exhaustive.

If the answer to one of the questions is **No**, first rectify the cause of the fault (or have it rectified) before starting work.

The checking and monitoring work listed below is described in greater detail in the following chapters.



**Start-up checklist**

Check and observe the following points before putting the vehicle into operation or starting the engine:

No.	Question	Page
1	Enough fuel in the tank?	<a href="#">7-23</a>
2	Water drained from the water separator?	<a href="#">7-25</a>
3	Correct engine oil level?	<a href="#">7-29</a>
4	Coolant level OK?	<a href="#">7-31</a>
5	Correct oil level in the hydraulic oil reservoir?	<a href="#">7-37</a>
6	Glass cleaner in washer reservoir?	<a href="#">7-41</a>
7	Lubrication points greased?	<a href="#">7-7</a>
8	Tracks checked for cracks, cuts, etc.?	--
9	Light system, mirrors, signaling, warning and indicator lights operational and/or adjusted correctly?	--
10	Windows, visual aids, lights, steps, all pedals and control levers clean?	--
11	All control levers and pedals in neutral position?	--
12	Does the window washing system function correctly?	--
13	Control lever base raised?	--
14	Are other persons required to guide you?	--
15	Attachment safely locked?	<a href="#">5-47</a> <a href="#">5-28</a>
16	Engine cover locked? Filler cap closed tightly?	<a href="#">7-17</a> <a href="#">7-23</a>
17	Tools and other loose objects removed?	--
18	Seating position adjusted correctly?	<a href="#">4-9</a>
19	Are all visual aids functional, clean and adjusted correctly?	<a href="#">4-13</a>
20	Seat belt fastened?	<a href="#">4-11</a>

**Operation checklist**

Check/observe the following before beginning operation or after starting the engine:

No.	Question	Page
1	Are there any persons or objects in the danger zone of the vehicle?	5-42
2	All indicator lights gone out?	4-28
3	Coolant temperature of engine in normal range?	4-28
4	Do the pedals and control levers work correctly?	--
5	Performed functional check of control lever base?	4-37
6	Functional check of the overload warning device performed?	5-46
7	Braking effect sufficient?	5-3

**Engine shut-off checklist**

Check and observe the following points when parking the vehicle:

No.	Question	Page
1	Attachment lowered to the ground?	5-37
2	Stabilizer blade lowered to the ground?	5-3
3	Control lever base raised?	4-37
4	Cab closed?	4-3

**When parking on slopes:**

5	Machine secured with wheel chocks in addition to prevent it from rolling away?	5-9
---	--	-----

## **Putting into operation for the first time and running-in period**

Before putting the vehicle into operation for the first time, check whether the equipment supplied with the vehicle is complete.

- Check the fluid levels according to chapter **“Maintenance”**.

Each vehicle is correctly adjusted and checked before it is delivered.

Handle the vehicle carefully during its first 50 operating hours.

- Do not load a cold engine.
- Warm up the vehicle at low engine speed and little load, do not warm it up at a standstill.
- Do not change engine speed abruptly.
- Avoid using the vehicle under heavy loads or at high speeds.
- Avoid abrupt acceleration, braking and changing travel direction.
- Do not run the engine at high speed for extended periods.
- Observe the maintenance plans – *see chapter “7.2 Maintenance overview” on page 7-2.*

## 4.5 Starting and stopping the engine

### Preparatory work

#### **WARNING**

##### **Accident hazard due to unintentional operation of the vehicle!**

Unintentional operation can cause serious injury or death.

- ▶ Only operate the vehicle from the seat with the seat belt fastened.

Set the throttle to the middle position if the engine is cold.

The starter cannot be actuated if the engine is already running (start repeat interlock).

Do not run the starter for more than 20 seconds.

Wait two minutes so the battery can recover and the starter does not overheat before trying again.

#### **NOTICE**

Possible damage to preheater if the preheating system is operated too long.

- ▶ Do not preheat the engine for more than 20 seconds.

#### **Information**

Provide for sufficient ventilation when operating in enclosed areas.

#### **Information**

All controls must be within easy reach. You must be able to move the drive levers to their limit positions.

### Ignition lock

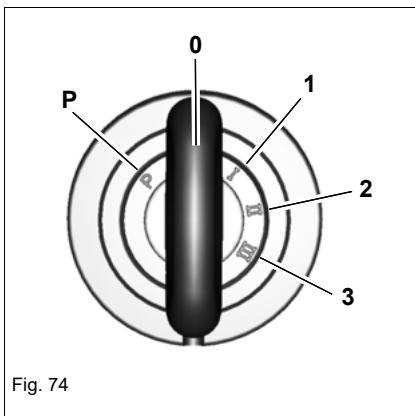
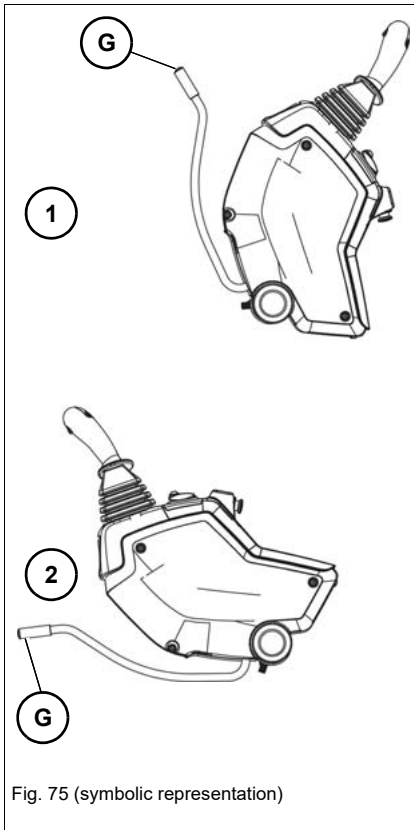

Fig. 74

Position	Function	
P	Park position	Not assigned
0	Stop position	Insert or remove the starting key
1	Machine travel position	All electric functions are enabled
2	Preheats the engine	Preheater active
3	Starts the engine	Starter is actuated

## Starting and stopping the engine



Control lever base	Position	Effect
Raised	<b>1</b>	The engine can be started
Lowered	<b>2</b>	The engine cannot be started

All hydraulic functions are locked if the control lever is raised with a running engine.

### Functional check of the joystick base

Before starting work, perform a functional check of the control lever base.

1. Start the vehicle.
2. Fold the control lever base **G** down.
3. Perform vehicle travel on open terrain.
4. Secure the danger zone.
5. Stop the vehicle.
6. Raise the control lever base **G**.
7. Move all control levers and pedals in all directions.
  - The selected elements do not move:
    - Work may be performed with the vehicle.
  - The selected elements move:
    - Stop operation immediately.

Contact a Wacker Neuson service center and have the malfunction rectified.

### NOTICE

Possible damage if the engine is started again immediately after stopping it.

- ▶ Wait at least two minutes before starting the engine again.

### NOTICE

Possible damage to preheater if the preheating system is operated too long.

- ▶ Do not preheat the engine for more than 20 seconds.

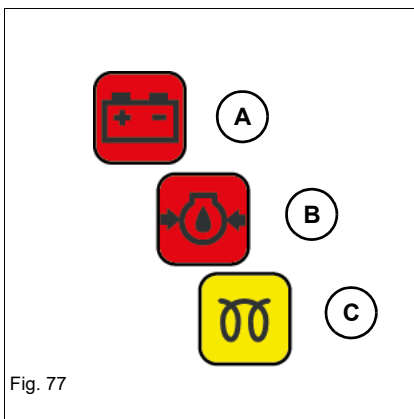
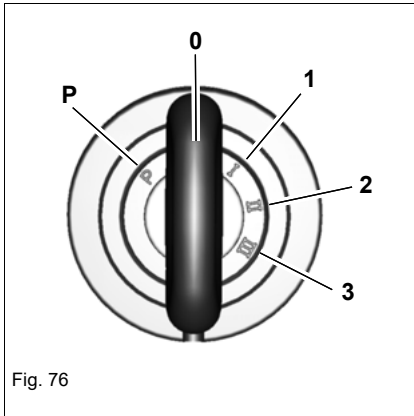

1. Insert the starting key.
2. Turn the starting key to position **1**.
3. Indicator lights **A – C** are illuminated for a few seconds.
  - ➔ If an indicator light does not function, contact a Wacker Neuson service center.
4. Turn and hold the starting key in position **2** until the indicator light for **pre-heating (A)** goes out.
  - ➔ The indicator lights **engine oil pressure (B)** and **alternator charging (A)** are illuminated.
5. Turn the starting key to position **3** until the engine runs.
  - ➔ All indicator lights go out.
  - ➔ If the engine does not start after 20 seconds:
6. Interrupt the start procedure and repeat it after two minutes.
  - ➔ If the engine still does not start after a few tries, contact a Wacker Neuson service center and have the error rectified.
7. Release the starting key as soon as the engine runs.

### Warm-up phase of vehicle

After the engine has started, allow it to warm up at slightly increased idling speed until the coolant reaches its operating temperature of about 80 °C (176 °F).

Do not let the vehicle warm up at standstill.

Check for unusual noise, exhaust color, leaks, malfunctions, or damage.

In case of malfunctions, damage, or leaks:

Secure the vehicle, park it and find out the cause for the damage and have it repaired.



### Information

Fold up the control lever base after shutting off **G** the engine.

## Starting aid

---

 **WARNING****Explosion hazard in case of incorrect handling of battery!**

Incorrect battery handling can cause serious injury or death.

- ▶ Wear protective equipment.
  - ▶ Fire, open flames and smoking is prohibited
  - ▶ Do not jump start the engine if the battery is malfunctioning or frozen, or if the acid level is too low.
- 

---

 **WARNING****Injury hazard due to rotating parts!**

Rotating parts can cause serious injury or death.

- ▶ Open the engine cover only at engine standstill.
- 

---

 **CAUTION****Burn hazard due to hot surfaces!**

Can cause serious burns or death.

- ▶ Stop the engine and let it cool down.
  - ▶ Wear protective equipment.
- 

---

**NOTICE**

Possible damage due to electrical short circuit or over-voltage.

- ▶ The positive terminal of the starting battery must not be brought into contact with electrically conductive vehicle components.
  - ▶ The vehicles must not touch each other during the starting aid.
  - ▶ If the engine still does not start despite a starting aid, contact a Wacker Neuson service center.
-



---

### **NOTICE**

Possible damage due to wrong battery voltage.

- ▶ Only use batteries with the same voltage (12 V).

---

### **NOTICE**

Possible damage to vehicle with empty battery due to voltage peaks.

---

### **NOTICE**

Possible damage to battery jumper cables when placing them near rotating parts.

- ▶ Do not place the battery jumper cables near rotating parts.





### **Information**

Use only authorized battery jumper cables which conform to national and regional safety requirements.

---

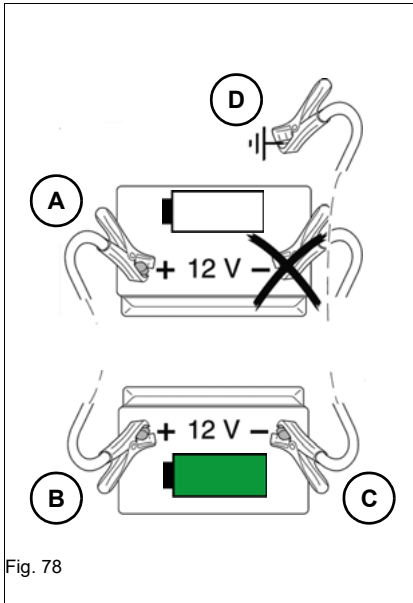



Designations/symbols	Meaning
<b>X</b>	Machine with empty battery
<b>Y</b>	Vehicle with full battery
<b>A</b>	Positive/vehicle <b>X</b>
<b>B</b>	Positive/vehicle <b>Y</b>
<b>C</b>	Negative/vehicle <b>Y</b>
<b>D</b>	Negative/vehicle <b>X</b> (A solid metal part screwed firmly onto the engine block or the engine block itself)
	Full battery
	Dead battery

1. Move vehicle **Y** close to machine **X** so that the length of the battery jumper cables is sufficient.
2. Stop the engine of vehicle **Y**.
3. Engine covers of both vehicles are open.
4. Connect the battery jumper cables in the following order: **A – B – C – D**.
5. Start the engine of vehicle **Y**.
6. Wait five minutes for the empty battery to be charged a little.
7. Start the engine of machine **X**.
8. Switch on the boom light of vehicle **X** in order to avoid voltage peaks and to protect the electronic system.
9. Disconnect the battery jumper cables in the following sequence: **D – C – B – A**.

### Low-load operation

---

**NOTICE**

Possible damage to the engine due to low-load operation.

- ▶ Run the engine at idling speed or at high engine speed at over 20% engine load.

---

Possible consequences of low-load operation are:

- Increased engine oil consumption.
- Dirt in engine due to engine oil in exhaust system.
- Blue smoke in exhaust gas.

### Stopping the engine

---

**NOTICE**

Possible damage to the engine when it is stopped after running under high load.

- ▶ Operate the engine at idling. This avoids engine damage and increases the service life.

- 
1. Let the engine run at idling speed for five minutes without any load.
  2. Turn the starting key to "0" and remove it.

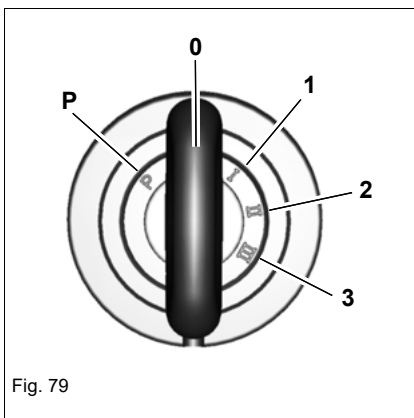

Fig. 79

## Battery master switch

---

### **NOTICE**

Possible damage to the electronics due to improper actuation of the battery master switch.

- ▶ Do not operate the battery master switch with a running engine.
- ▶ Operate the battery master switch no sooner than two minutes after shutting down the engine.

---

Actuate the battery master switch:

- If the vehicle is parked for longer periods of time (e.g. over the weekend).
- If the vehicle is to be protected against unintentional taking into service.
- If required by national and regional provisions.

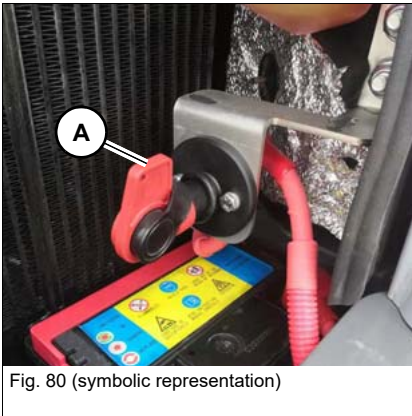

The battery master switch is located under the valve hood.

**Key A locked:**

Electric power supply enabled

**Key A removable:**





Electric power supply disabled



Notes:

## 5 Operation

### 5.1 Steering system

Movement	Drive levers/accelerator pedals
Steering to the left	
Steering to the right	
Rotation to the left	
Rotation to the right	

## 5.2 Accelerator actuation

### Manual throttle

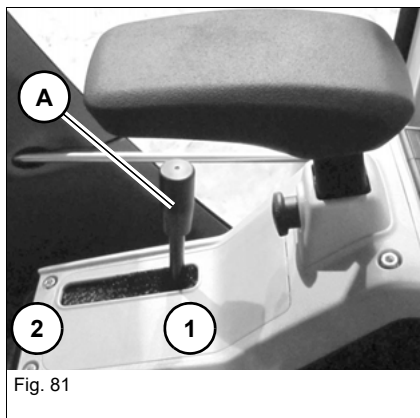

Engine speed can be set continuously with throttle **A**.

Engine speed	Position
Idling speed	1
Maximum	2

### Speed range selection

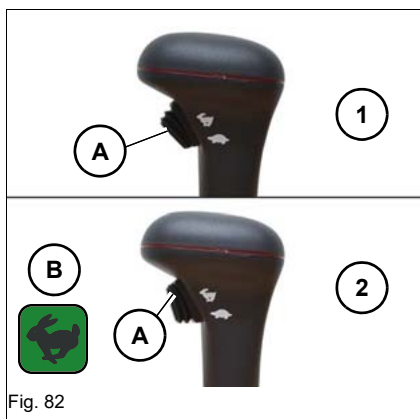

The vehicle has two speed ranges that can be selected with switch **A** on the dozer blade lever.

1: Speed 1

2: Speed 2 (control lamp **B** appears in the display element)

#### Information

In speed 2, reduced tractive power jerky movements may occur when cornering due to the lower traction force.

## Automatic engine speed setting

The diesel engine shifts to idling speed if the hydraulics are not operated for a few seconds.

If the hydraulic system is operated, the diesel engine runs at the engine speed set with the manual throttle.

This automatic revs setting is switched on and off with the **A** switch.

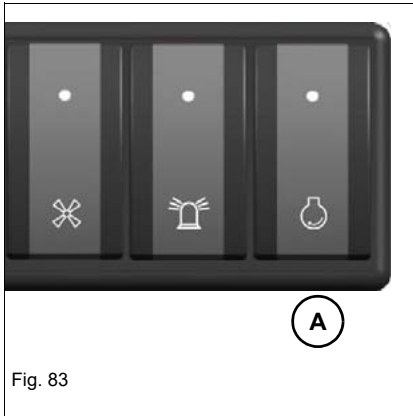

## 5.3 Brake

### Hydraulic brake

The vehicle will slow down when the drive levers or accelerator pedals are released.

During downhill vehicle travel, the automatic hydraulic brake valves prevent the vehicle from moving faster than the permissible travel speed.



#### Information

Reduce the speed with the drive levers or accelerator pedals, and not with the throttle.

### Mechanical brake

The stabilizer blade is used as a parking brake. Press the stabilizer blade against the ground.

## 5.4 Machine travel

### Machine travel position

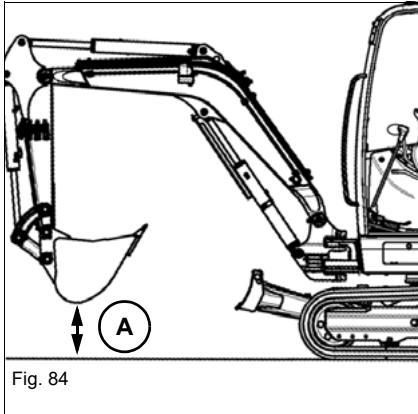

Position the vehicle as shown.

Position the boom at the center and raise it off the ground.

- A = 20-30 cm (8-12 in)

### Starting vehicle travel and stopping

#### **WARNING**

##### **Accident hazard due to incorrect vehicle operation!**

The vehicle moves in the opposite direction if the upper carriage is rotated by 180° and the drive levers are actuated.

Incorrect operation can cause serious injury and death.

- ▶ Slowly and carefully actuate the control levers.

#### **WARNING**

##### **Accident hazard due to incorrectly rotated upper carriage!**

If rotated incorrectly, the upper carriage blocks the visibility of the travel path. This may cause serious injury or death.

- ▶ Before starting vehicle travel on a construction site, align the superstructure so that the operator has an unrestricted view of the travel path.

#### **Starting vehicle travel**

Operate the drive levers or accelerator pedals.

- The vehicle starts moving.

#### **Stopping**

Release the drive levers or accelerator pedals.

- The vehicle stops.

#### **Information**

The control lever base must be folded down in order to start vehicle travel.



## Operating temperature range

Operate the vehicle only at ambient temperatures between  $-15\text{ }^{\circ}\text{C}$  ( $5\text{ }^{\circ}\text{F}$ ) and  $+45\text{ }^{\circ}\text{C}$  ( $+113\text{ }^{\circ}\text{F}$ ).

## Operating limits

### Limits of use of the vehicle

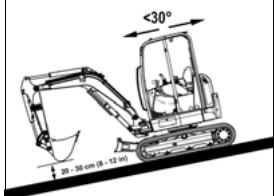
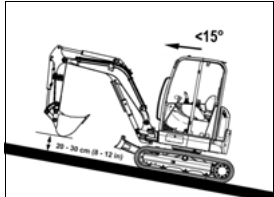
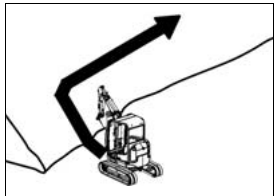
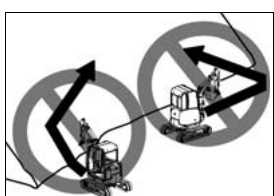
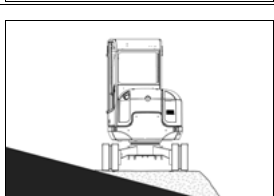
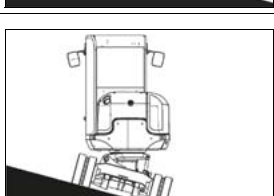
Application	Description
	<p><b>Uphill and downhill driving (boom system on the downhill side)</b> Permitted up to a slope inclination of <math>30^{\circ}</math></p>
	<p><b>Uphill and downhill driving (boom system on the uphill side)</b> Permitted up to a slope inclination of <math>15^{\circ}</math></p>
	<p><b>Lateral slope drive</b> Permitted up to a slope inclination of <math>15^{\circ}</math></p>
	<p><b>Diagonal drive</b> Prohibited</p>
	<p><b>Working on lateral slopes</b> Only permitted on a horizontal, load-bearing and level surface</p>
	<p><b>Working on lateral slopes (VDS)</b> Permitted up to a slope inclination of <math>15^{\circ}</math> and on a horizontal, load-bearing and level surface</p>

---

 **WARNING****Crushing hazard due to tipping over of vehicle!**

A tipping vehicle can cause serious injury or death.

- ▶ Raise the boom 20 – 30 cm (8 – 12 in) off the ground and position it straight ahead at the center of the vehicle.
- ▶ In an emergency, lower the boom immediately to increase stability.
- ▶ Travel on slopes only on firm and level ground.
- ▶ Adapt the travel speed to the prevailing conditions.
- ▶ Pay attention to persons and obstacles.
- ▶ Pay attention to the operating limits of the vehicle.
- ▶ Perform uphill and downhill machine travel only in speed range 1.
- ▶ Never reverse downhill.
- ▶ Ensure that no parts of the body protrude outside the vehicle.
- ▶ Do not exceed the permissible payloads.
- ▶ Do not turn or swivel the upper carriage and the boom during downhill or uphill vehicle operation with a full attachment.
- ▶ Diagonal machine travel is prohibited.

---

Stones and the humidity in the upper layer of the ground can affect vehicle traction and stability.

The vehicle can slip sideways on gravel or loose, rocky soil. The stability of the vehicle can be reduced on rough terrain.

On soft ground, the vehicle sinks into it or the tracks dig into it. This increases the vehicle angle (maximum gradient angle and maximum lateral angle of inclination), and the vehicle can tip over.

If the engine dies as you perform uphill or downhill vehicle travel, immediately put the control levers to neutral position and restart the engine.

Observe under all circumstances during uphill or downhill travel:

- Keep the drive levers near the neutral position.
- Perform slow and smooth travel movements.
- Avoid sudden travel movements.
- Reduce the engine speed.

The vehicle can slip even on gentle slopes if it travels across grass, leaves, humid metal surfaces, frozen ground or ice.

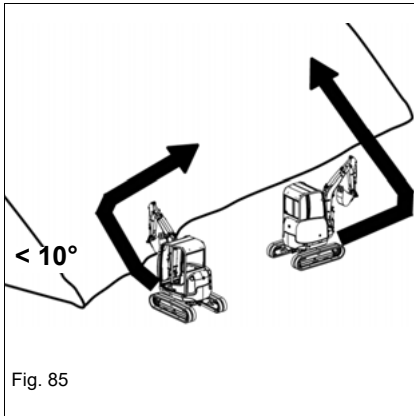

Fig. 85

**Preparations for performing vehicle travel on slopes**

Always perform uphill or downhill vehicle travel in a straight line.

When changing position, do not exceed a maximum gradient angle of 15° and a maximum lateral angle of inclination of 10°.

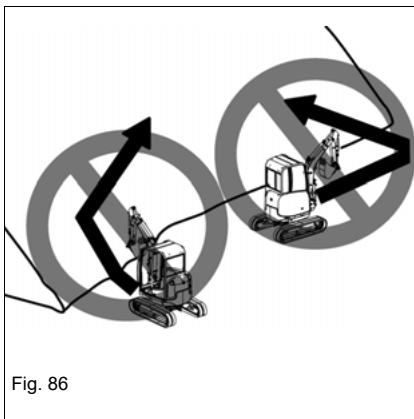
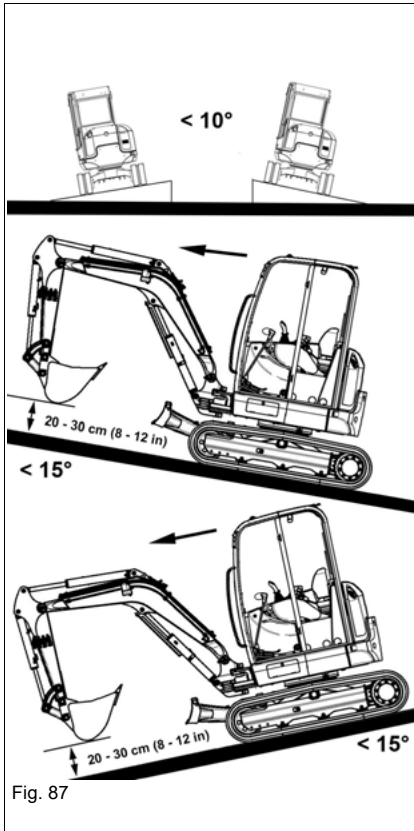

Fig. 86

Change position on level ground and then perform straight-ahead vehicle travel onto the slope.



### Uphill vehicle operation

- Raise the boom 20 – 30 cm (8 – 12 in) off the ground and position it straight ahead at the center of the vehicle.
- Do not perform vehicle travel on slopes steeper than  $15^\circ$ .
- Do not perform machine travel on slopes with a lateral angle of inclination over  $10^\circ$ .

### Downhill vehicle operation

- Raise the boom 20 – 30 cm (8 – 12 in) off the ground and position it straight ahead at the center of the vehicle.
- In order to minimize the risk of tipping over, adapt the travel speed to the circumstances.
- Do not perform vehicle travel on slopes steeper than  $15^\circ$ .
- Do not perform machine travel on slopes with a lateral angle of inclination over  $10^\circ$ .

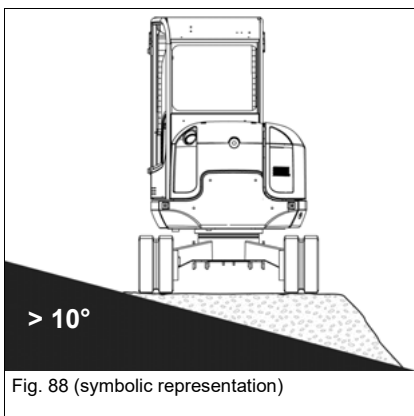

On lateral inclinations over  $10^\circ$ , pile up material to create a horizontal, firm and level standing surface for the vehicle.

## Parking the vehicle

### **WARNING**

**Crushing hazard due to vehicle rolling away under its own weight after parking it!**

Serious injury or death can be caused by not securing the vehicle.

- ▶ Lower the boom and the stabilizer blade to the ground.
- ▶ Secure the vehicle accordingly (for example with chocks).

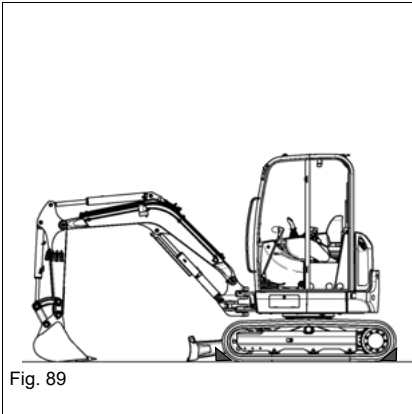

1. Park the vehicle on firm, level, and horizontal ground.
2. Position the boom straight ahead at the center of the vehicle.
3. Lower the boom and the stabilizer blade to the ground.
4. Stop the engine
5. Relieving the pressure of the hydraulic system – *see chapter “Release the pressure of the work hydraulics” on page 5-39.*
6. Remove the starting key and carry it with you.
7. Raise the control lever base.
8. Close the windows and doors.
9. Close and lock all covers and doors.
10. Secure the vehicle with wheel chocks (see *Fig. 89*).

### **Information**

In order to prevent the formation of condensation water, fill up the fuel tank nearly completely at the end of each working day.

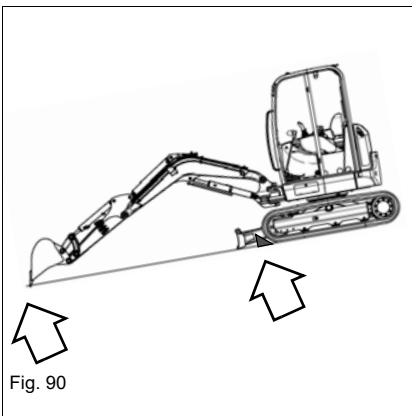

### **Parking the vehicle on slopes**

If parking the vehicle on a slope cannot be avoided, observe the following in addition:

- Position the boom on the downhill side of the vehicle and firmly press the attachment into the ground.
- Place stabilizer blade on the downhill side.
- Press the stabilizer blade against the ground.
- Secure the vehicle with wheel chocks (see *Fig. 90*).

## 5.5 Differential lock

Not available.

### 5.6 Lights/signaling system

---

 **WARNING**

**Motorists can be blinded by bright lights on the job site!**

Working lights can blind motorists. This can cause serious injury or death.

- ▶ Stop vehicle operation if motorists are blinded.
  - ▶ Take up operation again only when sufficient illumination of the working area is ensured without blinding motorists.
- 

 **Information**

Switch on the working lights in conditions of poor visibility. If illumination still is not sufficient, use external lights. If this is yet not enough to illuminate the job site sufficiently, stop vehicle operation and only start it again when sufficient illumination can be ensured.

---

**Working lights**

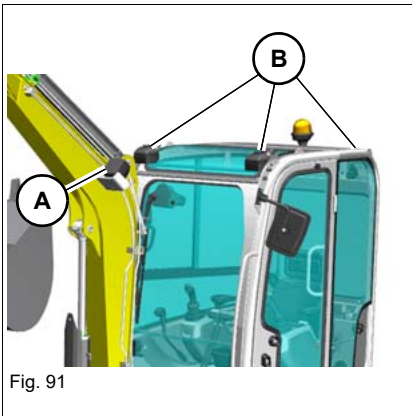

Fig. 91

The vehicle can be equipped with the following lights:

- **A:** Boom headlight (standard)
- **B:** Roof headlights (two at the front, one at the rear; option)

Optionally the lights can be equipped with energy-saving LED lamps.

The switch is located on the left switch panel.

Working lights	Switches
On/off	

**Interior light**



Fig. 92

Interior light	Operation
On	Press light to the left or right
Off	Press the light to the center position

**Horn**

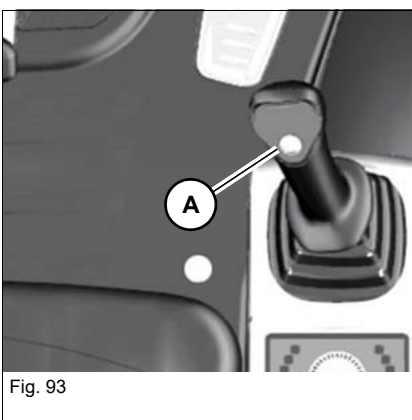
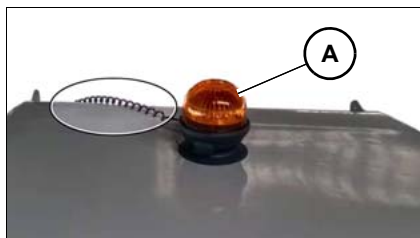

Fig. 93

Press button **A** on the right-hand joystick to actuate the horn.

## Rotating beacon



The rotating beacon has a magnetic base and is attached to the cabin roof. Wrap the cord around the right c-pillar and connect the power plug to the 12-volt connection inside the cabin.

---

**i** **Information**

Observe the national and regional regulations.

---



Fig. 94



## 5.7 Washer system

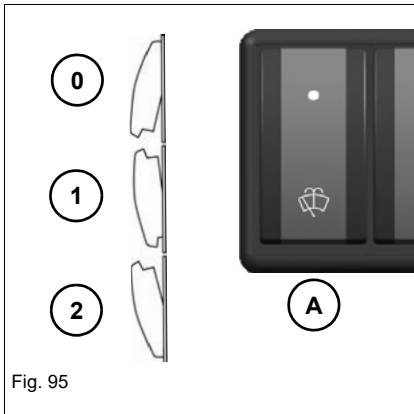

The switch is located on the switch panel on the right.

Washer system	Operation
Wipers on	Press switch <b>A</b> into position <b>1</b>
Wipers off	Press switch <b>A</b> into position <b>0</b>
Spraying on	Press switch <b>A</b> into position <b>2</b> and hold
Spraying off	Release switch <b>A</b>

### **NOTICE**

Damage to pump if the reservoir is empty.

- ▶ Do not actuate the washer system if the reservoir is empty.
- ▶ Check the level in the reservoir and add a cleaning solution (glass cleaner) if necessary.

### **NOTICE**

Damage to wiper if the front window is raised.

- ▶ Do not actuate the wipers if the front window is raised.

## 5.8 Temperature setting

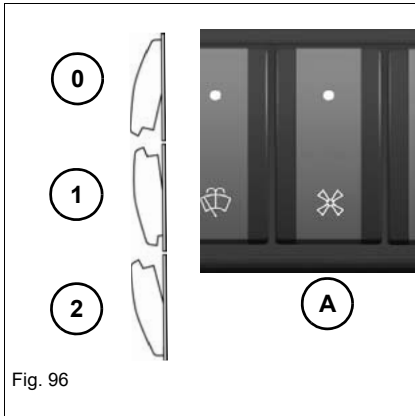

Fig. 96

### Fan

The switch is located on the switch panel on the right.

Fan	Operation
Off	Press switch <b>A</b> into position <b>0</b>
1st range	Press switch <b>A</b> into position <b>1</b>
2nd range	Press switch <b>A</b> into position <b>2</b>

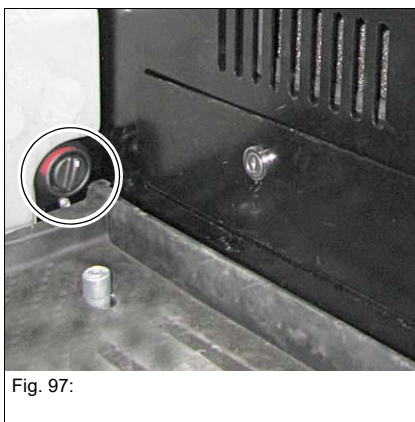

Fig. 97:

### Temperature

The rotary control is located on the right in the footwell.

Temperature	Operation
Higher	Turn rotary control counterclockwise
Lower	Turn the rotary control clockwise

## Traveling signal

A travel signal sounds as soon as at least one of the tracks moves.

### **WARNING**





























#### **Accident hazard during forward/backward vehicle operation!**

Danger of crushing that may lead to serious injuries or death.

- ▶ Do not allow anyone to stay in the danger zone.
- ▶ Despite the traveling signal the danger zone must also be monitored visually.
- ▶ If the travel signal does not sound, stop vehicle operation immediately and contact a Wacker Neuson service center. Follow the relevant national and regional regulations.

## 5.9 Operating hydraulics

### Basic control lever functions (ISO and SAE controls)

Control mode	Required function	ISO controls		SAE controls	
		Joysticks <sup>1</sup>		Joystick <sup>1</sup>	
		Left	Right	Left	Right
					
	Rotating the upper carriage to the left		--		--
	Rotating the upper carriage to the right		--		--
	Extend stick		--	--	
	Retract the stick		--	--	
	Lower the boom	--			--
	Raise the boom	--			--
	Tilt in the bucket	--		--	
	Tilt out the bucket	--		--	

1. The control levers shown are symbolic representations.

## ISO/SAE controls

The standard equipment of the vehicle includes ISO controls. SAE controls are available as an option. This results in a different control lever operation.

### **WARNING**

#### **Accident hazard due to modified control mode!**

Modified controls can cause incorrect operation, and serious injury or death.

- ▶ Before starting work, check the selected control type.
- ▶ Secure the wing nut on the changeover lever of the directional valve.
- ▶ Do not operate the machine with a defective wing nut. Contact a Wacker Neuson service center.

The changeover valve is located under a cover on the left behind the seat.



Fig. 98

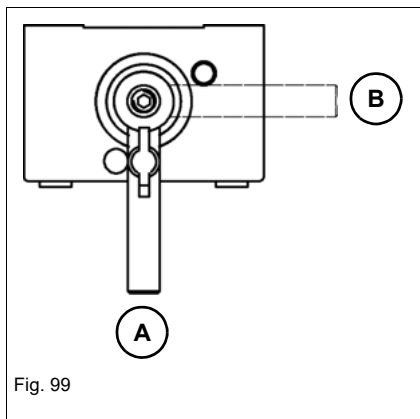

Fig. 99

Wiring diagram	Controls
A	ISO controls
B	SAE controls

## Swiveling the boom

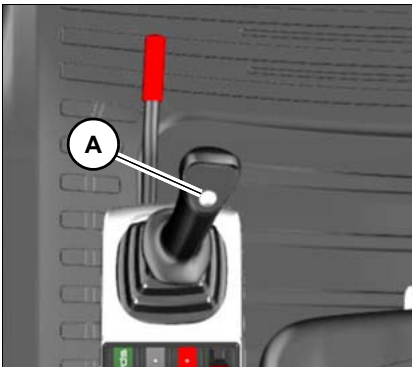

Fig. 100:

Press and hold button **A** on the control lever base on the left.

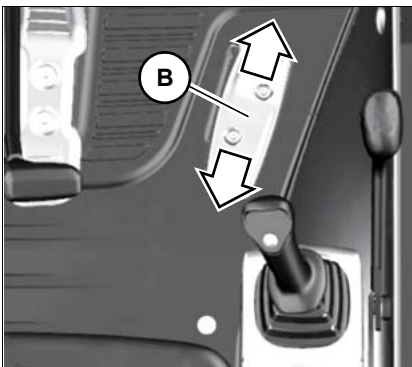

Fig. 101:

### Swiveling the boom to the right:

Press pedal **B** forward.

### Swiveling the boom to the left:

Press pedal **B** to the rear.

## Swiveling the boom (proportionally controlled)

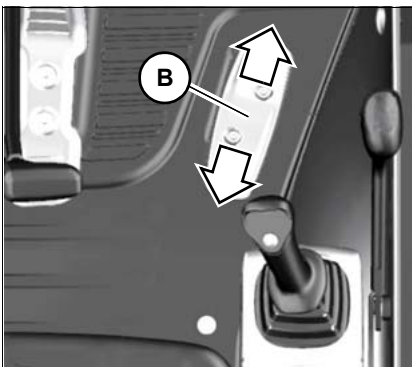

Fig. 102:

### Swiveling the boom to the right:

Press pedal **B** forward.

### Swiveling the boom to the left:

Press pedal **B** to the rear.

## Rotating the upper carriage

### **WARNING**

#### **Crushing hazard due to rotating range of vehicle!**

Persons in the rotation range of the vehicle can be seriously injured or killed.

- ▶ Do not allow anyone to stay in the danger zone.

### **NOTICE**

Possible damage to vehicle when working in the immediate vicinity of walls, parts of buildings or other obstacles.

- ▶ Ensure that there are no obstacles in the danger zone.

### **Information**

As long as the hydraulic fluid has not reached its operating temperature, the upper carriage can continue moving after releasing the control lever. Operate the control lever carefully in a cold operating state.

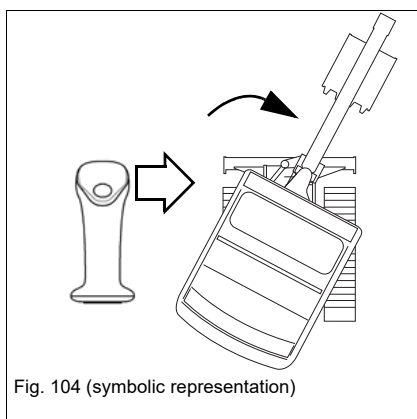
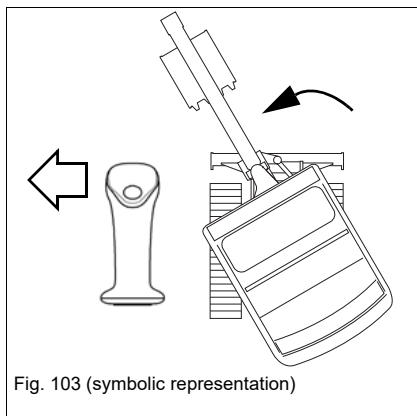

Rotating the upper carriage	Position
To the left	Push the control lever on the left to the left
To the right	Push the control lever on the left to the right

## Swivel unit brake

### Automatic swivel unit brake

When the upper carriage is rotated, the swivel unit brake is enabled with a time delay to hold the upper carriage.

The swivel unit brake is disabled again if the upper carriage is rotated again.

### Hydraulic swivel unit brake

Normal braking: release the control lever.

Maximum braking: press the control lever in the opposite direction until the upper carriage is at a standstill.

## Functional check of swivel unit brake

Perform the functional check on a warm vehicle after work once a day.

If the vehicle is put into operation again after a standstill of more than two weeks, perform a functional check once **before starting work**.

1. Park the vehicle on firm, level, and horizontal ground.
2. Raise the vehicle with the stabilizer blade as far as it will go.

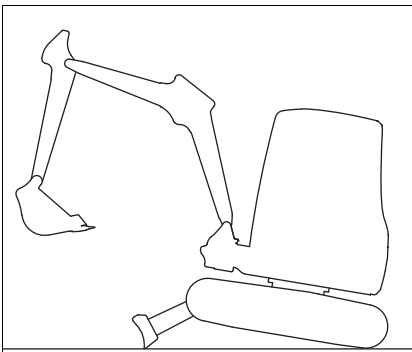

Fig. 105 (symbolic representation)

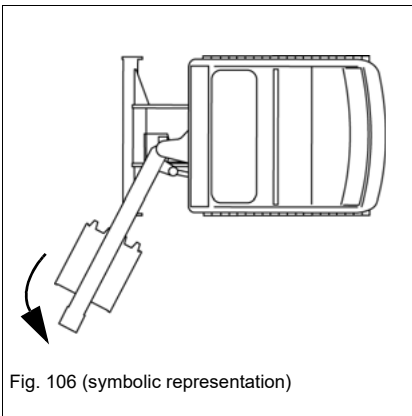
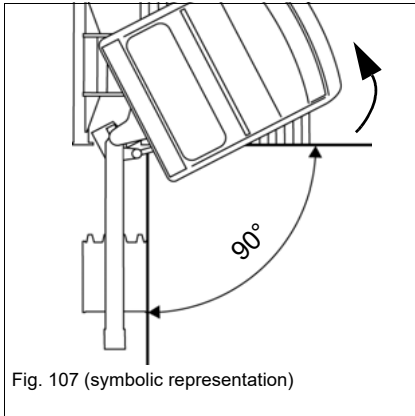
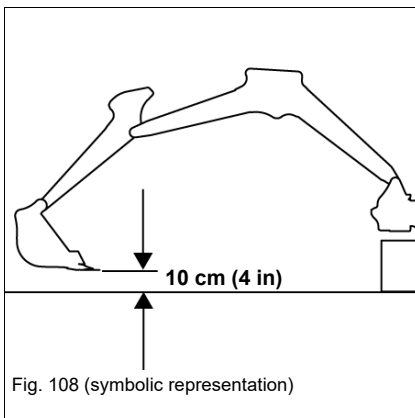

Fig. 106 (symbolic representation)

3. Swivel the boom to the left as far as it will go.



4. Turn the upper carriage so that the boom is 90° to the travel gear.



5. Position the boom as shown in [Fig. 108](#).

6. Stop the engine, remove the starting key and carry it with you.

7. Raise the control lever base.

8. Wait one minute.

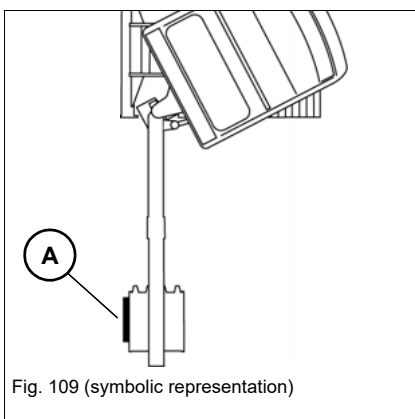

9. Put a measuring rod **A** against the attachment.

10. Wait one minute.

➤ If the attachment does not move from the measuring rod:

➤ Machine is ready for operation.

➤ If the attachment moves from the measuring rod:

➤ Stop operation immediately.

➤ Contact a Wacker Neuson service center and have the malfunction rectified.



**Dozer blade**

---

**WARNING**
**Crushing hazard due to unintentional actuation!**

Unintentional actuation can cause serious injury or death.

- ▶ Raise the control lever base.
  - ▶ Lower the stabilizer blade to the ground after the work shift.
  - ▶ Do not allow anyone to stay in the danger zone.
- 

**NOTICE**

Lowering the stabilizer blade too deeply into the ground can create increased resistance.

- ▶ Slightly raise the stabilizer blade. The clearance between the stabilizer blade and the ground should be about 1 cm (0.4 in).
  - ▶ Check the stabilizer-blade position before performing vehicle travel.
- 

**Information**

In order to achieve the best possible stability, lower the stabilizer blade.

The stabilizer blade is also used as a parking brake. Press the stabilizer blade against the ground.

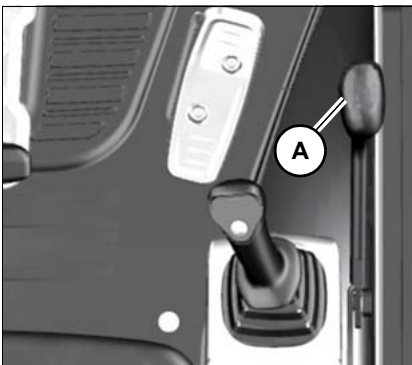

Fig. 110

Stabilizer blade	Position
Raise	Pull lever <b>A</b> backward
Lower	Push lever <b>A</b> forward

### Hammer operation

Only hammer in the allocated work area and only with splinter protection (canopy) or closed front window (cab) – *see chapter “Shatter protection” on page 4-19.*

The vehicle with canopy is not certified for demolition work according to EN 474-5. A front guard cannot be attached.

---

#### **WARNING**

##### **Danger of piercing/penetration by objects from the front!**

Work involving risk of piercing/penetrating by objects from the front can cause accidents with serious injury or death.

- ▶ Observe the mandatory limits of the work area.
- ▶ Do not hammer horizontally or upward.
- ▶ Only hammer with attached shatter protection or closed front window.

---

#### **WARNING**

##### **Accident hazard due to tipping over of vehicle!**

A tipping vehicle can cause serious injury or death.

- ▶ Never turn, lower or set down the attachment abruptly.
- ▶ Do not extend or retract the boom abruptly.
- ▶ Use a hammer only at vehicle standstill.

---

#### **Information**

In combination with Powertilt, only use the smallest possible released hydraulic hammer.

---

## Working with a hydraulic hammer

### NOTICE

In order to avoid damage to the vehicle or hydraulic hammer, observe the following points:

- ▶ Observe the Operator's Manual of the hydraulic hammer.
- ▶ Do not hammer horizontally or upward.
- ▶ Do not use the hammer to raise loads.
- ▶ Do not hit the hammer against rocks, concrete, etc.
- ▶ Do not hammer in the same spot uninterruptedly for more than 15 seconds.
- ▶ Do not raise the vehicle with the boom.
- ▶ Do not work with fully extended cylinders or arm system. Do not pivot the Powertilt unit beyond 30° during hammer operation, otherwise the load on the boom increases tremendously.
- ▶ Stop vehicle operation immediately if a hydraulic hose moves back and forth in an unusual manner. The pressure accumulator could be malfunctioning. Contact a Wacker Neuson service center and have the malfunction rectified immediately.

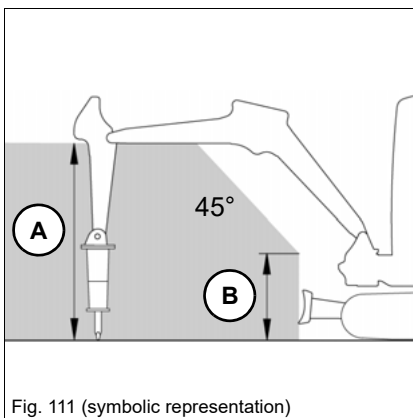

Fig. 111 (symbolic representation)

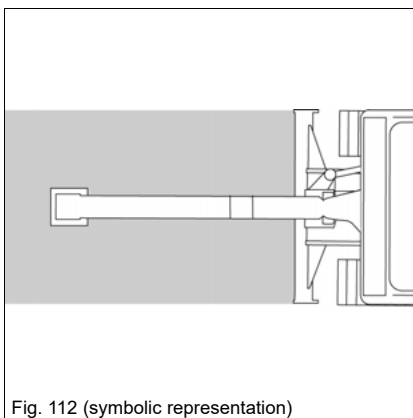

Fig. 112 (symbolic representation)

### Job site

Work range height **A**: 120 cm (47 in), **B**: 50 cm (20 in)

Figures 111 and 112 refer to work with a Wacker Neuson hydraulic hammer.

Working with another tool can result in a different work area.

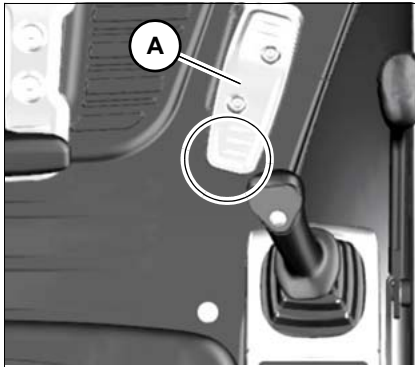

Fig. 113:

Hammer operation	Position
On	Actuate the pedal <b>A</b> in the rear
Off	Release the pedal <b>A</b>

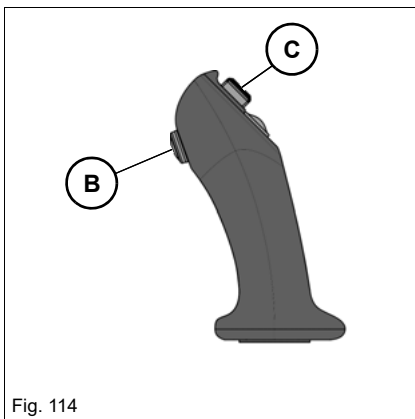

Fig. 114

Breaker operation (proportional control)	Position
Switch on	Hold down touch control <b>B</b> on the right joystick
Switch off	Release touch button <b>B</b>



**Information**

The hydraulic breaker can be operated with the gate **C**.

## 5.10 Additional control circuits

### AUX I

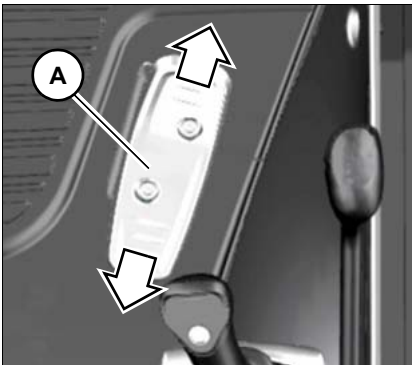

Fig. 115

The operation occurs with pedal **A**.

Oil flow	Position
To the line on the left	Actuate the pedal <b>A</b> in the rear
To the line on the right	Press the pedal <b>A</b> forward

### AUX I/II/III (proportional controls)

The proportional controls allow to continuously adjust the oil flow for the attachment.

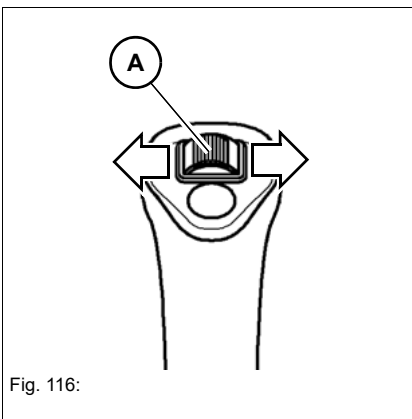

Fig. 116:

Function	Operation
AUX I	Control lever on the right
AUX II/III	Control lever on the left

Oil flow	Position
To the line on the left	Press rocker switch <b>A</b> to the left
To the line on the right	Press rocker switch <b>A</b> to the right

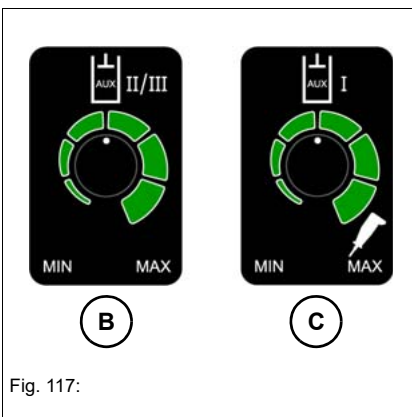

Fig. 117:

Set the desired oil flow with the rotary controls **B** (AUX II/AUX III) or **C** (AUX I).

### AUX III operation (Powertilt)

#### **WARNING**

**Crushing hazard due to rotating movements of the Powertilt unit!**

Rotating the Powertilt unit can cause serious injury or death.

► Do not allow anyone to stay in the danger zone.

#### **Information**

The Powertilt unit may only be installed and removed by a Wacker Neuson service center!

For more information, see **Easy Lock/Powertilt with Easy Lock Operator's Manual**.

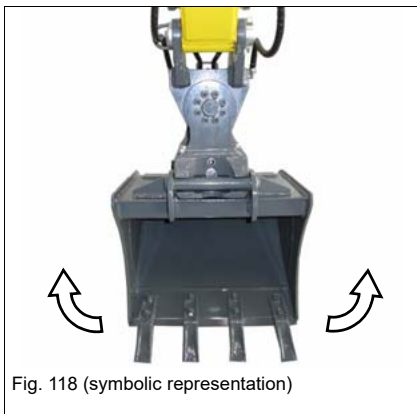

Function <sup>1</sup>	Operation
Rotation to the left	Press rocker switch <b>A</b> to the left
Rotation to the right	Press rocker switch <b>A</b> to the right

1. Depending on the system used or the valid norm, the rotation of direction may differ.

## Preparation for hydraulic quickhitch

The hydraulic quickhitch preparation is a hydraulic auxiliary control circuit attached to the vehicle boom that was designed, developed and released for the hydraulic quick coupler systems described in this operator's manual.

Wacker Neuson is not liable for injuries or damage if at least one of the following items is not complied with:

- Follow the operator's manual for the hydraulic quickhitch.
- Store the Operator's Manual of the hydraulic quickhitch together with the Operator's Manual of the vehicle.
- For non-released quickhitch systems, there may be differences in the operating functions or the operation of the vehicle. Observe the operator's manual of the quickhitch system or the attachment.

Nevertheless, should a non-approved hydraulic quickhitch be used, the following points must also be observed:

- If required, modifications on the vehicle (for example additional adhesive labels) or the Operator's Manual of the vehicle (if operation is different) must be made.
- The intended purpose of the vehicle may be restricted.
- Assembling a hydraulic quick coupler system that does not fit with the vehicle or its interface (e.g. pressure settings) may void the declaration of conformity of the vehicle. Contact a Wacker Neuson service center.
- Assembling a hydraulic quick coupler system to a vehicle that does not fit with the vehicle or its interface (e.g. pressure settings) may void the declaration of conformity of the hydraulic quick coupler. Contact a Wacker Neuson service center.

### AUX IV - Hydraulic quickhitch system Easy Lock

- Attend specific training before putting into operation. Training must be given by authorized technical personnel and must be understood by the operator.
- For safety reasons, the quickhitch must be operated with two control elements. This avoids opening the quickhitch unintentionally during work operation.
- The quick coupler system and the attachment support must be undamaged and clean.
- For more information, see **Easy Lock/Powertilt with Easy Lock** Operator's Manual.
- Store the **Easy Lock/Powertilt with Easy Lock** operator's manual together with the vehicle's operator's manual.



#### **WARNING**

##### **Crushing hazard when picking up attachments!**

If an attachment is not locked correctly, it can come off and cause serious injury or death.

- ▶ Do not allow anyone to stay in the danger zone.
- ▶ Do not use damaged attachments.
- ▶ Check pin **F** must be fully retracted. Otherwise repeat the lock cycle until check pin **F** is retracted.
- ▶ Ensure safe locking with a rapid succession of stick and bucket movements as close as possible to the ground.
- ▶ Operate the vehicle only with a safely locked attachment.



#### **WARNING**

##### **Danger of crushing when attachments are removed!**

If an attachment is not locked correctly, it can tip over and cause serious injury or death.

- ▶ Do not allow anyone to stay in the danger zone.
  - ▶ Lower the attachment to level and firm ground ensuring stability.
-



**WARNING**

**Danger of crushing due to incorrect operation of the hydraulic quickhitch system!**

For system-specific reasons, the quickhitch can also be operated with other hydraulic functions. This can cause serious injury or death.

- ▶ Operate the hydraulic quickhitch only with the function **Raise stabilizer blade**.

**Picking up an attachment**

Fig. 119:

1. Hook up the quick coupler system **A** in the bolts **B** of the attachment receptacle.
2. Extend the bucket cylinder so that pin **C** of the attachment touches the quickhitch.
3. Check whether the attachment touches the quick coupler system with the bolt **C**.
4. Move the attachment inward completely.

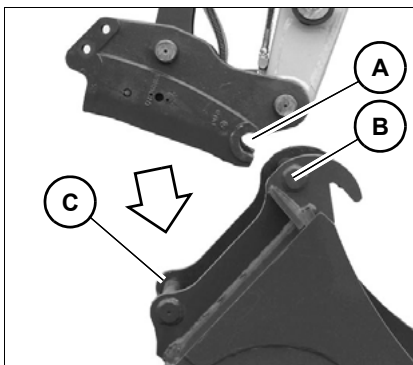
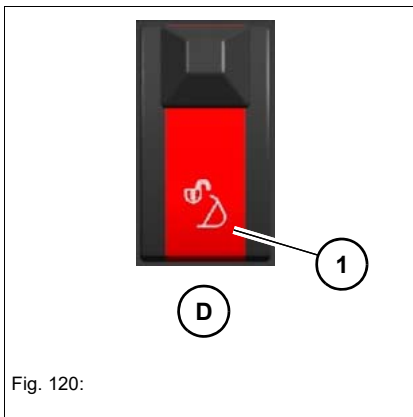

Fig. 120:

5. Unlock switch **D** and press it to position **1**.
  - ➔ The quickhitch is enabled and the buzzer sounds.

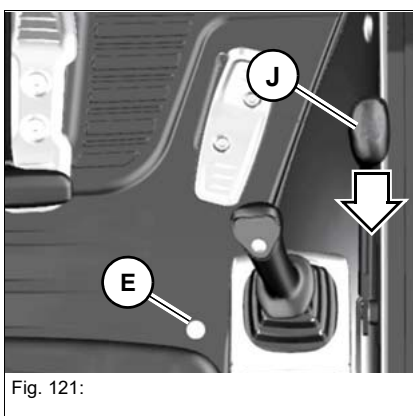

Fig. 121:

6. Press and hold the foot-operated touch button **E** and at the same time pull back the **J** dozer blade lever.
  - ➔ The quickhitch opens.

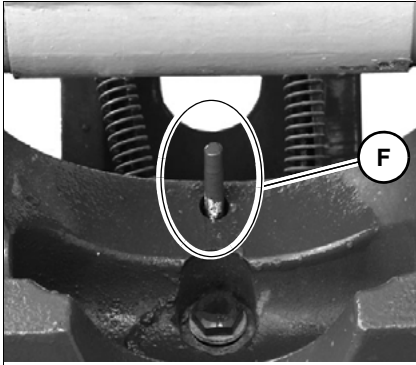

Fig. 122:

- Check pin **F** must be fully extended.
- The attachment engages.

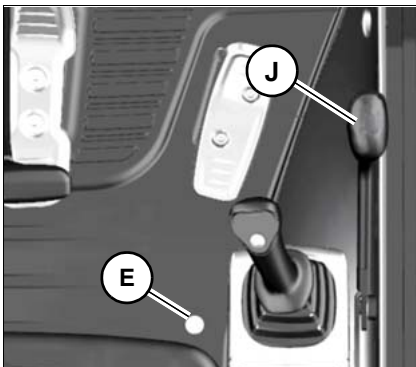

Fig. 123:

7. Release the dozer blade lever **J** and foot-operated touch button **E**.
  - The quickhitch closes.

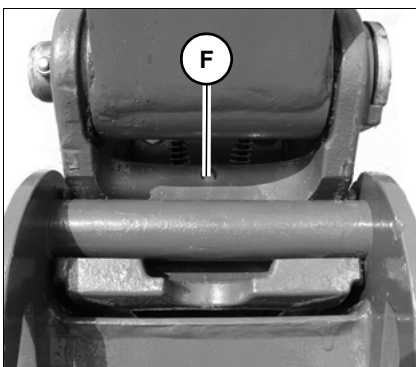

Fig. 124:

- Check pin **F** must be fully retracted.

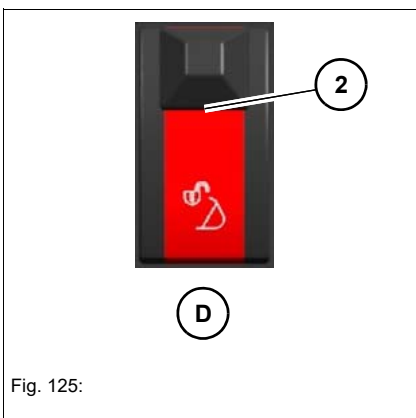

Fig. 125:

8. Press switch **D** to position **2**.
  - The quickhitch is disabled and the buzzer does not sound any longer.

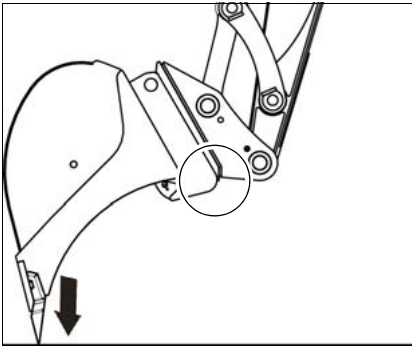

Fig. 126

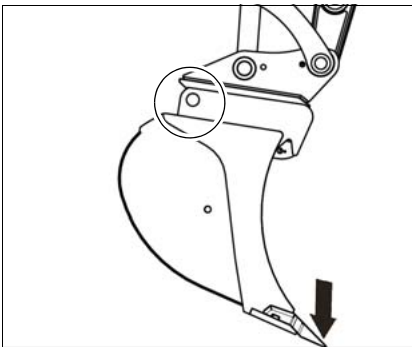

Fig. 127

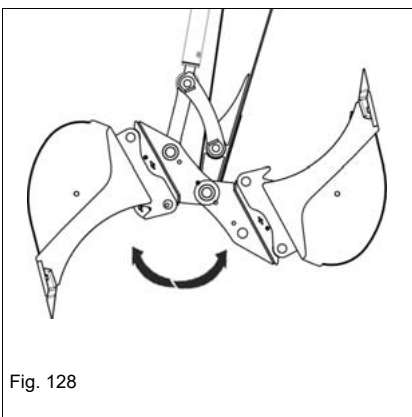

Fig. 128

9. Before starting any work and after every locking process, press the attachment to the ground and quickly move it back and forth over just over the ground a few times to check the secure locking.
- The attachment may not detach from the quick coupler system in the process.

### Manual hydraulic quick hitch bolt lock

Depending on national provisions, the hydraulic quick hitch must also be manually locked according to the hydraulic locking process.

The locking or unlocking is located to the left on the quick coupler system.

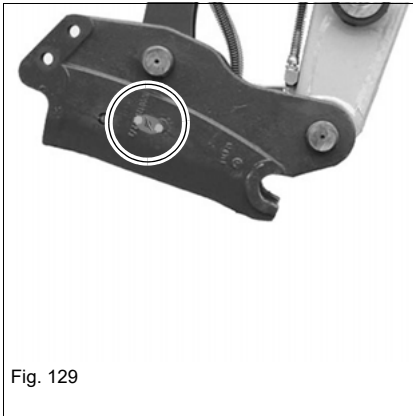

Fig. 129

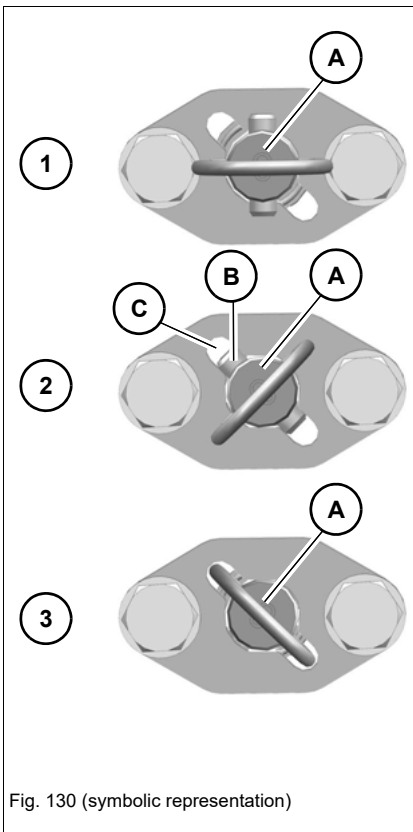

Fig. 130 (symbolic representation)

- Stop the engine and remove the starting key.
- Raise the control lever base.
- Rotate bolt **A** so that the pin **B** fits in the recess **C** (2).
- Press in the bolt **A** and turn until it is held in its position by the spring (3).
  - ➔ The hydraulic quick hitch is also manually locked.

#### **i** Information

Comply with national provisions.

#### **i** Information

The bolt positions may deviate in their final position from the figures.

**Setting down an attachment**

**Manual hydraulic quick hitch bolt unlocking**

Depending on national provisions, the hydraulic quick hitch must also be manually unlocked according to the hydraulic unlocking process.

The locking or unlocking is located to the left on the quick coupler system.

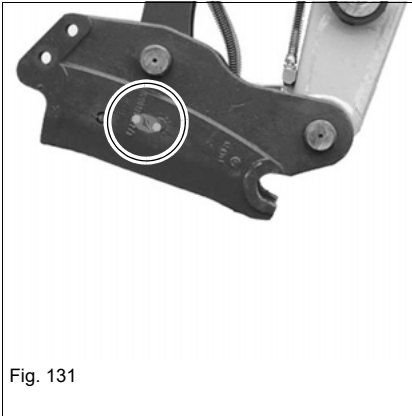

Fig. 131

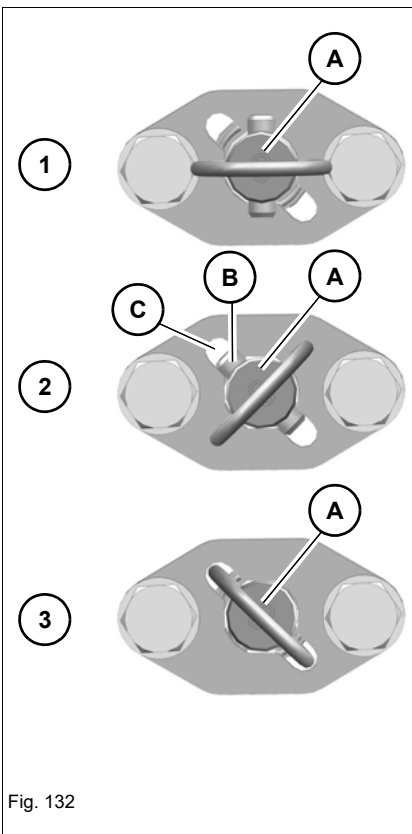

Fig. 132

- Stop the engine and remove the starting key.
- Raise the control lever base.
- Rotate bolt **A** so that the pin **B** fits in the recess **C** (2).
- Pull out the bolt **A** (1).
  - ➔ The hydraulic quick hitch is manually unlocked. The attachment is still hydraulically locked.

---

**i Information**  
Comply with national provisions.

---



---

**i Information**  
The bolt positions may deviate in their final position from the figures.

---

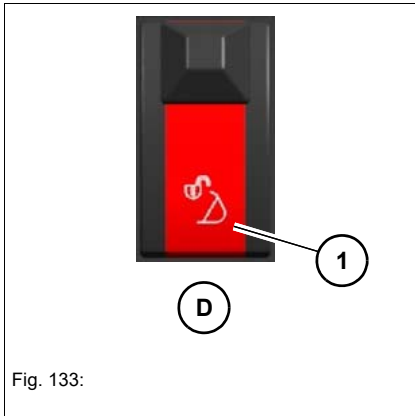

Fig. 133:

1. Move the attachment inward completely and position it at 5–10 cm (2–4 in) above the ground.
2. Unlock switch **D** and press it to position **1**.
  - The quickhitch is enabled and the buzzer sounds.

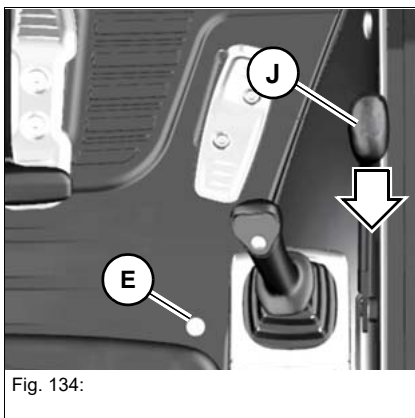

Fig. 134:

3. Press and hold the foot-operated touch button **E** and at the same time pull back the **J** dozer blade lever.
  - The quickhitch opens.

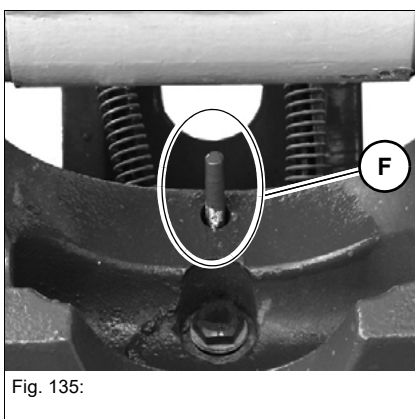

Fig. 135:

- Check pin **F** must be fully extended.

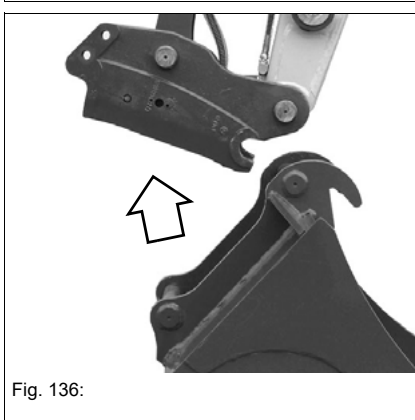

Fig. 136:

4. Retract the bucket cylinder.
  - The attachment is lowered to the ground.

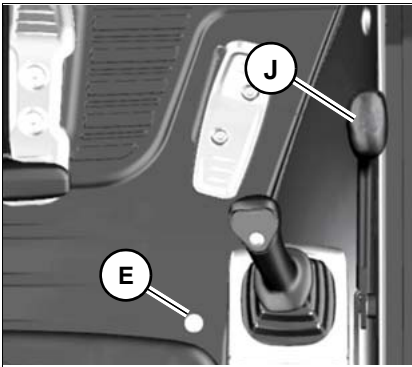

Fig. 137:

5. Release the dozer blade lever **J** and foot-operated touch button **E**.  
➔ The quickhitch closes.

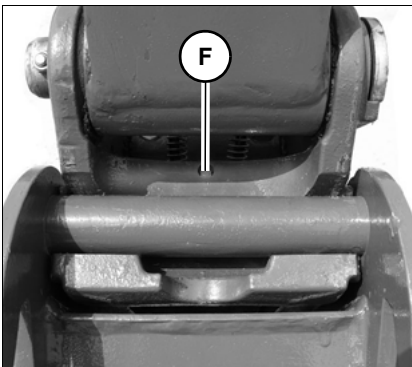

Fig. 138:

- ➔ Check pin **F** must be fully retracted.

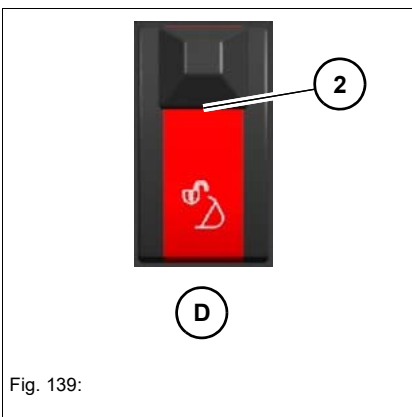
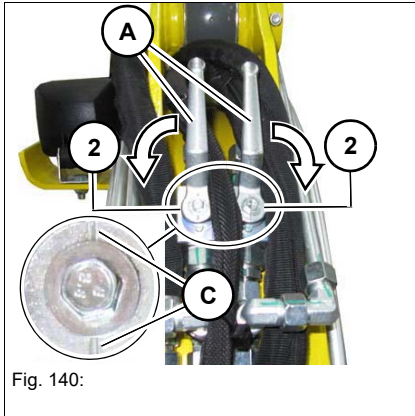

Fig. 139:

6. Press switch **D** to position **2**.  
➔ The quickhitch is disabled and the buzzer does not sound any longer.

## AUX V

**Setting grab operation**

1. Move both levers **A** on the ball valve to position **2**.
  - Notch **C** indicates the flow direction.

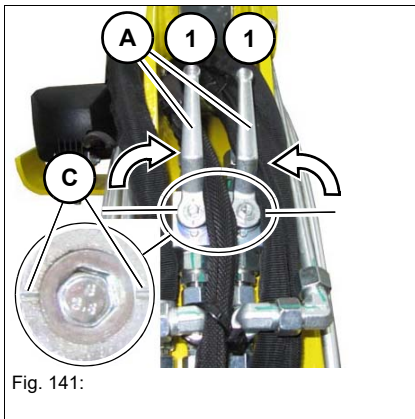
**Setting bucket operation**

1. Move both levers **A** on the ball valve to position **1**.
  - Notch **C** indicates the flow direction.



## 5.11 Attachments

### Picking up

---

#### **WARNING**

##### **Injury hazard due to fluid escaping under pressure!**

Hydraulic oil escaping under pressure can penetrate the skin and cause serious injury or death.

- ▶ Do not allow anyone to stay in the danger zone.
  - ▶ Release the pressure in the hydraulic system before connecting or disconnecting the attachment – *see chapter “Release the pressure of the work hydraulics” on page 5-39.*
  - ▶ Wear protective clothes.
  - ▶ Always consult a doctor immediately, even if the wound seems insignificant. Hydraulic oil causes blood poisoning.
- 

#### **WARNING**

##### **Accident hazard when picking up attachments!**

Picking up attachments incorrectly can cause serious injury or death.

- ▶ Wear protective equipment during installation of the connecting pins.
  - ▶ Do not allow anyone to stay in the danger zone.
  - ▶ Only use attachments that are in perfect condition.
  - ▶ Set and adjust the boom to the correct position with the control levers.
  - ▶ Align the fastening bores in the attachment with a mandrel to make it easier to insert the pin in the bores.
  - ▶ Ensure correct locking with a rapid succession of stick and bucket movements as close as possible to the ground.
  - ▶ Operate the vehicle only with a safely locked attachment
-

---

### Setting down

---

#### **WARNING**

##### **Crushing hazard when attachments are removed!**

If an attachment is not removed correctly, it can tip over and cause serious injury or death.

- ▶ Do not allow anyone to stay in the danger zone.
  - ▶ Lower the attachment to level and firm ground ensuring stability.
  - ▶ Only remove the pins from the attachment if it is in a stable position.
  - ▶ Lower the attachment to the ground without too much pressure, otherwise the resistance when removing the pins is too high.
- 

The procedure of changing attachments is described below for a backhoe bucket.

Follow the special information when fitting or removing attachments with their own hydraulic functions (for example an offset bucket). Observe the Operator's Manual of the attachment.

---

#### **Information**

The hydraulic system of the vehicle is still pressurized even when the engine is not running. Due to the residual pressure, the hydraulic quick couplers can be removed but not installed back on again.

- ▶ Release the pressure.
-

## **Release the pressure of the work hydraulics**

1. Stop the vehicle on firm, level, and horizontal ground.
2. Lower the attachment completely to the ground.
3. Lower the stabilizer blade to the ground.
4. Stop the engine
5. Turn the starting key to position **1**.
6. Move the control lever or the pedal of the hydraulic circuit in all directions repeatedly.
  - The pressure reduces. This can be seen by the brief movement the hoses make as the pressure is released.
  - Uncouple the attachment immediately after the pressure has been released, otherwise pressure can be created again.

### **Pressure releases with proportional controls**

1. Park the machine on horizontal and level ground.
2. Lower the attachment completely to the ground.
3. Stop the engine
4. Turn the starting key to position **1**.
  - Release the load only after you have engaged the starter and waited 2 seconds (otherwise if actuated too early, the characteristic curve is shifted and the load is not released).
5. Release the pressure on the auxiliary hydraulics or the 3rd control circuit by pressing the rocker switch connected with the left or right-side proportional joystick to the left and right.
  - The pressure reduces. This can be seen by the brief movement the hoses make as the pressure is released.
  - Uncouple the attachment immediately after the pressure has been released, otherwise pressure can be created again.

### Connecting and disconnecting hydraulic couplings

1. Park the vehicle – see chapter “Preparing lubrication” on page 7-7.
  2. Turn the starting key to position 1.
  3. Release the pressure of the work hydraulics – see chapter “Release the pressure of the work hydraulics” on page 5-39
  4. Remove the starting key and carry it with you.
- ➔ The couplings of the attachment can now be coupled and uncoupled.

### Hydraulic connections

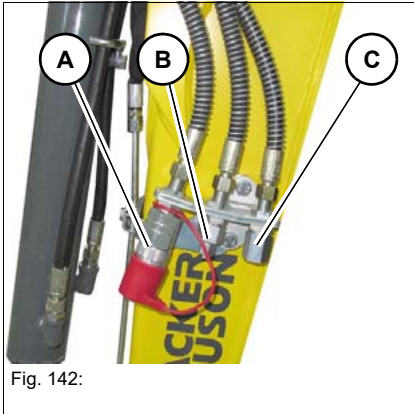

Fig. 142:

Connection	Stick (left/right)
A	AUX V
B	AUX II/AUX III
C	AUX I
D	Hammer return line

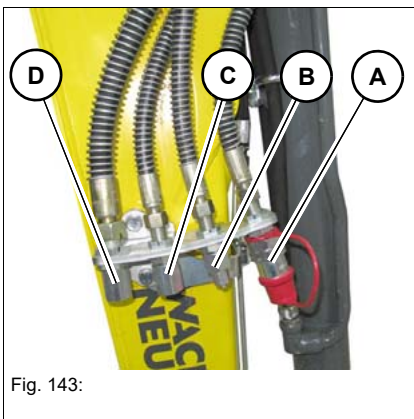

Fig. 143:

### **i** Information

Follow the instructions in the Operator's Manual of the attachment manufacturer for connecting the hydraulics to the attachment.

### Proceed as follows after a damage:

1. Stop the vehicle immediately.
2. Stop the engine
3. Move the control lever or stabilizer blade lever to neutral.
4. Perform emergency lowering if possible – see chapter “5.13 Emergency lowering” on page 5-57
5. Raise the control lever base.
6. Remove the starting key and lock the cabin.
7. Secure the vehicle and the attachment.
8. Contact a Wacker Neuson service center and have the malfunction rectified.



### Environment

Use a suitable container to collect fluids and lubricants as they flow out and dispose of them in an environmentally friendly manner.

## Re-equipping

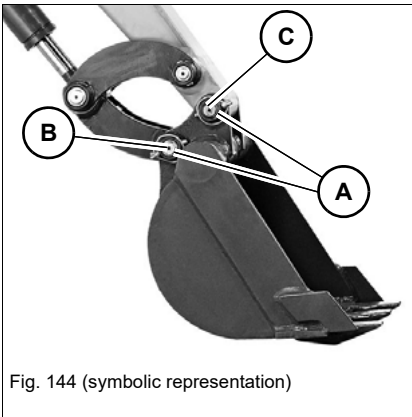

### Removing

1. Lower the bucket to level ground with the flat side facing downward.
2. Stop and park the vehicle Stop the engine See "Preparing lubrication".
3. Remove linch pins **A**.
4. First remove pin **B**, and then pin **C**. Carefully expel pins that are stuck with a hammer and a brass punch.

If pin **C** is stuck:

1. Start the engine.
2. Slightly raise and lower the boom to take the load off the pin.
3. Stop and park the vehicle Stop the engine See "Preparing lubrication".
4. Raise the control lever base.
5. Remove the starting key and carry it with you.



### Information

Place the bucket only with minimum pressure on the ground as you remove the pins. The higher the pressure on the ground, the higher the resistance and the more difficult it is to remove the pins.

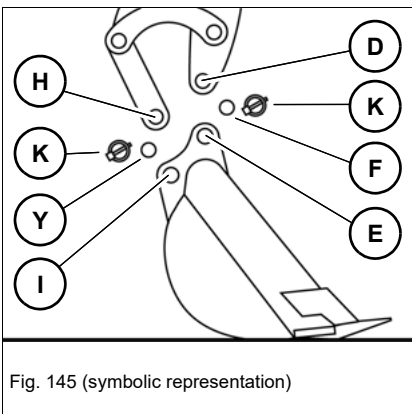

### Mount

1. Install a bucket only if it is positioned on level ground with the flat side facing downward.
2. Stop and park the vehicle Stop the engine See "Preparing lubrication".
3. Apply grease to the pins and articulations before inserting them.
4. Start the engine.
5. Straighten the shovel arm so that bores **D** and **E** are flush.
6. Stop the engine Raise the control lever base.
7. Insert pin **F**.
8. Actuate the bucket cylinder until bores **H** and **I** are flush.
9. Stop the engine Raise the control lever base.
10. Insert pin **J**.
11. Install linch pins **K**.

## 5.12 Work operation

### Danger zone

- The danger zone is the area in which persons are in danger due to the movements of the vehicle, attachment or load.
- The danger zone also includes the area that can be affected by falling material, equipment or by parts that are thrown out.
- The danger zone on a slope is different from the one on a level surface (secure the load) See chapter “**Operation, driving on slopes**”.
- Stop vehicle operation immediately if persons do not stay clear of the danger zone.
- Seal off the danger zone should it not be possible to keep a sufficient safety distance.
- Extend the danger zone sufficiently in the immediate vicinity of buildings, scaffolds or other elements of construction.

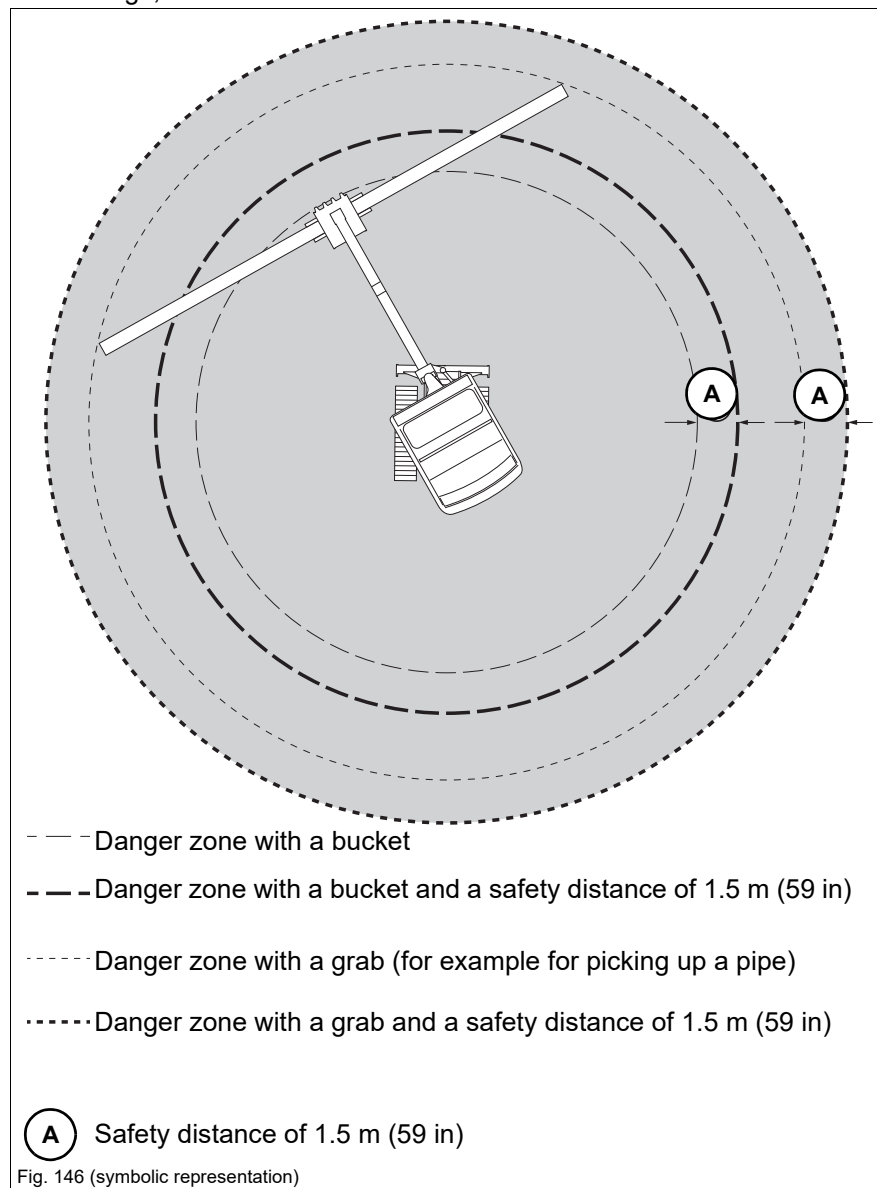

**Danger zone during lifting-gear applications**

In lifting gear applications the load must be stabilized by slingers (B) with the help of ropes (C).

Slingers must remain out of the danger zone – see chapter “Danger zone during lifting-gear applications” on page 5-43.

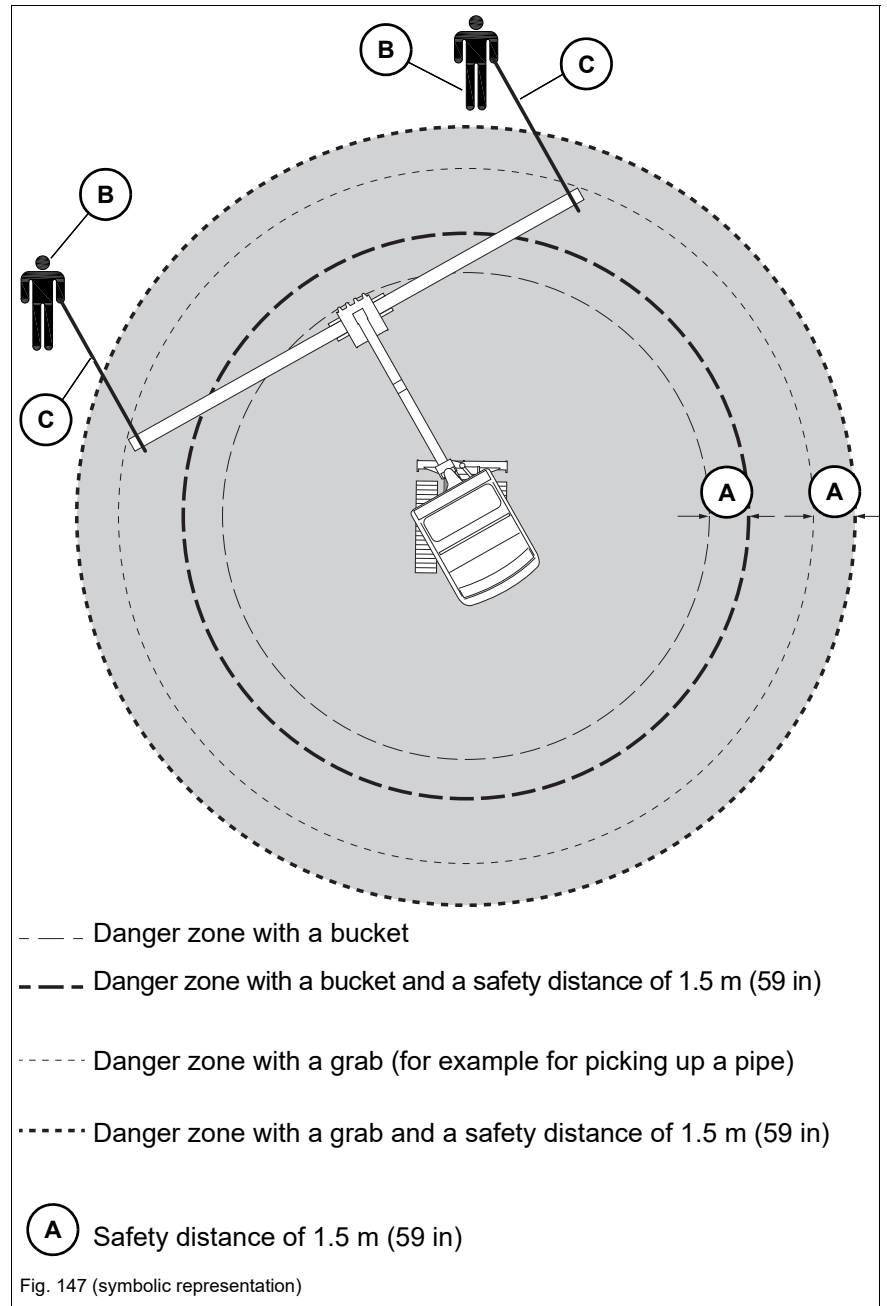

### Lifting gear applications

Lifting gear applications are procedures involving raising, transporting and lowering loads with the help of lifting and fastening gear.

---

#### **DANGER**

##### **Crushing hazard due to tipping over of vehicle!**

The vehicle causes serious injury or death when it tips over.

- ▶ Do not exceed the weights indicated in the load diagrams.
  - ▶ Subtract the weight of the attachment from the weight specified in the relevant load diagram.
  - ▶ Use the vehicle for lifting gear applications only if the mandatory lifting gear and safety equipment is installed, functional and enabled.
  - ▶ The subgrade must be horizontal, even, and have a high load-bearing capacity.
- 

#### **WARNING**

##### **Risk of vehicle tipping over due to failure to pay attention to the safe load indicator!**

Serious injury or death can be caused by a vehicle tipping over.

- ▶ Reduce the load until both the buzzer and the indicator light on the display element go out.
  - ▶ Observe the load diagrams.
- 

#### **WARNING**

##### **Accident hazard due to switched-off or malfunctioning safe load indicator!**

Serious injury or death can be caused by a vehicle tipping over.

- ▶ Switch on the safe load indicator during lifting gear applications.
  - ▶ Operate the vehicle only with an intact safe load indicator.
-



---

**NOTICE**

Machine damage due to a vehicle tipping over if the weight in the load diagram is exceeded.

- ▶ Do not exceed the weights indicated in the load diagrams.
- 

**Safe load indicator**

The safe load indicator alerts the operator visually and acoustically if the load on the boom is too high.

There are two versions:

- Overload warning device **basic/advanced**

Position	basic	advanced
Boom	Hose burst valve	Hose burst valve
Shovel arm	Hose burst valve	Hose burst valve
Stabilizer blade	Hose burst valve	Counterbalance valve

The switch for activating and deactivating the safe load indicator is located on the switch panel on the left.

Safe load indicator	Switches
On/off	

**Functional check of safe load indicator**

Always perform a functional check of the safe load indicator before performing lifting gear applications.

1. Start the vehicle.
2. Perform vehicle travel on open terrain.
3. Secure the danger zone.
4. Stop the vehicle.
5. Switch on the safe load indicator.
6. Raise the boom as far as it will go and hold the control lever in this position.

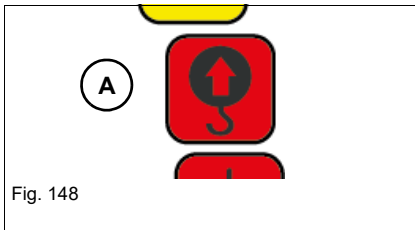

Fig. 148

Warning devices	Result
The buzzer sounds and symbol <b>A</b> is displayed	The vehicle may be used for lifting gear applications.
Buzzer does not sound or symbol <b>A</b> is not displayed	The vehicle may not be used for lifting gear applications. Contact a Wacker Neuson service center.

**Perform a functional check of the control lever base.**

– see chapter “*Functional check of the joystick base*” on page 4-37

Only the following lifting gear may be used for lifting gear applications:

- Powertilt/quickhitch with load hook
- Joint rod with lifting eye

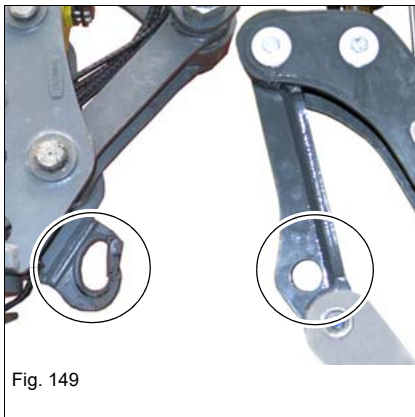

Fig. 149



Fig. 150

When symbol **A** is displayed and the buzzer sounds:

- Reduce the load until the buzzer goes out and the symbol disappears.
- Suitable equipment for fastening and securing loads must be available.

## Lehnhoff mechanical quickhitch system (optional)

- The quick coupler system and the attachment support must be undamaged and clean.
- Store the Operator's Manual of the mechanical quick coupler system together with the Operator's Manual of the vehicle.
- The described operation does not apply to the face shovel. Contact an authorized workshop for face shovel operation.

---

### **WARNING**

#### **Crushing hazard when picking up attachments!**

If an attachment is not locked correctly, it can come off and cause serious injury or death.

- ▶ Do not allow anyone to stay in the danger zone.
- ▶ During locking and unlocking procedures, make sure that hands and feet are not crushed.
- ▶ Only use undamaged attachments and quick coupler systems.
- ▶ Before starting any work and after every locking process, press the attachment to the ground and quickly move it back and forth over just over the ground a few times to check the secure locking.
- ▶ Only operate the vehicle with a safely locked attachment.

---

### **WARNING**

#### **Crushing hazard when attachments are removed!**

If an attachment is not removed correctly, it can tip over and cause serious injury or death.

- ▶ Do not allow anyone to stay in the danger zone.
- ▶ Lower the attachment to level and firm ground ensuring stability.

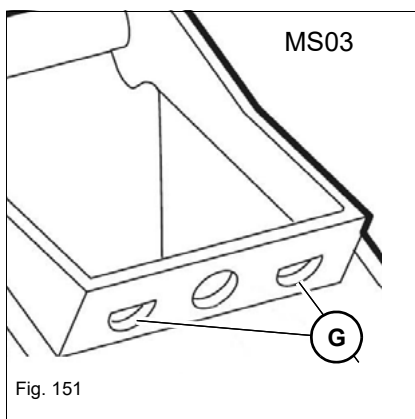

#### **Acceptance variants**

EZ25: Support for MS03

**G:** Openings for quick coupler system bolts

**Picking up an attachment**

1. Hook up the quick coupler system **A** in the attachment bolt **B**.
2. Slightly screw in the quick coupler system **A**, lift the shovel arm until the attachment is suspended about 30 cm (12 in) above the ground.
3. Extend the bucket cylinder so that the edge **C** of the attachment touches the quick coupler system.

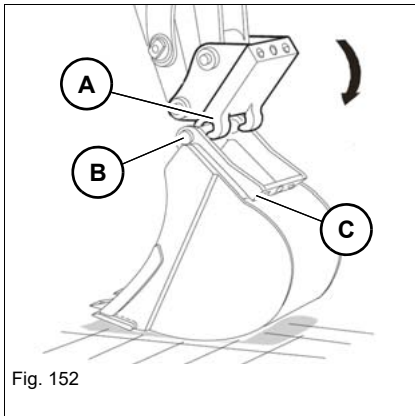

4. Screw in the quick coupler system **A** until the attachment lies completely on the quick coupler system **A** due to its weight.
5. Shut off the engine and store the ignition switch key safely.

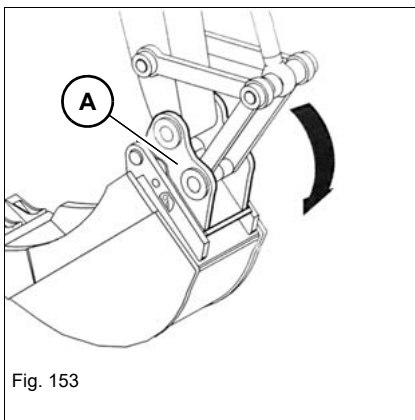

6. Screw socket wrench **D** clockwise until the bolts **E** completely engage in the openings **G** of the quick coupler system **A**.
  - The quick coupler system is locked.
7. Remove the socket wrench and perform a visual inspection.
8. Start the engine.

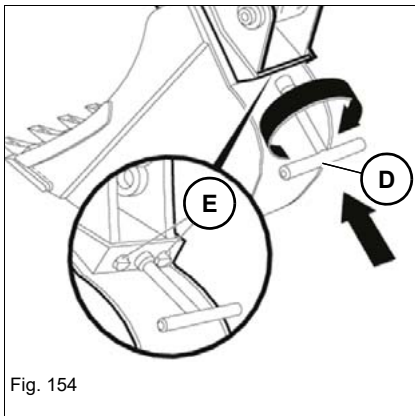

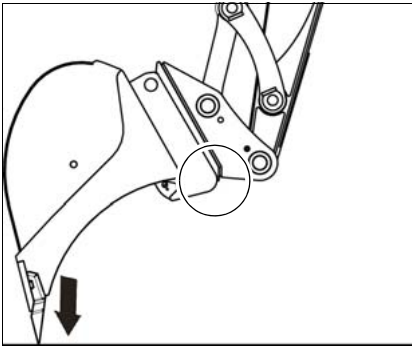

Fig. 155

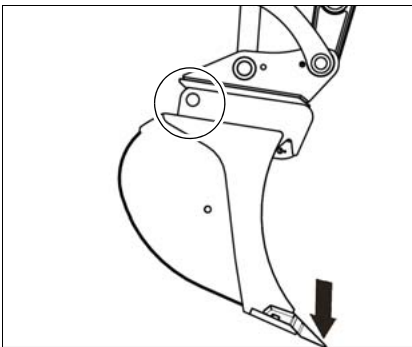

Fig. 156

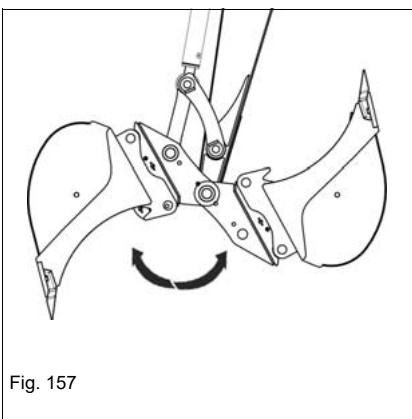

Fig. 157

9. Before starting any work and after every locking process, press the attachment to the ground and quickly move it back and forth over just over the ground a few times.
- ➔ The attachment may not detach from the quick coupler system in the process.

### Setting down an attachment

1. Screw in the attachment and position it at 5–10 cm (2–4 in) above the ground.
2. Shut off the engine and store the ignition switch key safely.

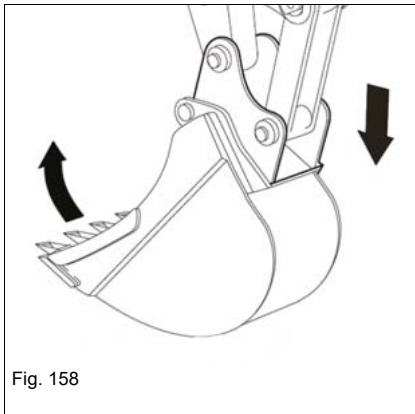

Fig. 158

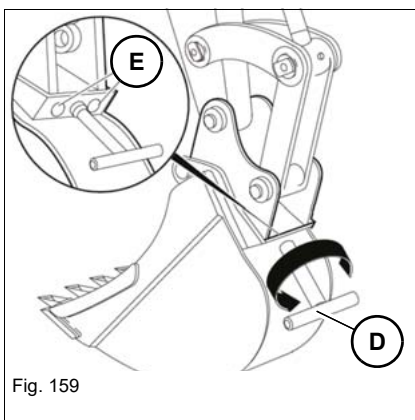

Fig. 159

3. Turn the socket wrench **D** counter-clockwise until the bolts **E** are completely retracted.
  - The quick coupler system is unlocked.
4. Remove the socket wrench.
5. Start the engine.
6. Lower the attachment to level and firm ground ensuring stability.

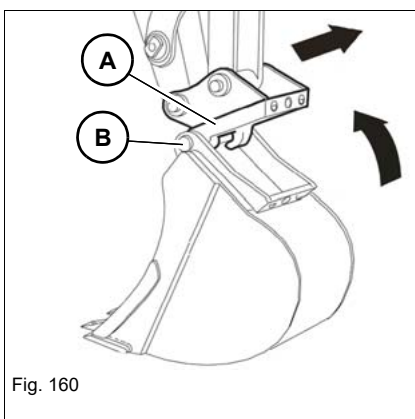

Fig. 160

7. Retract the bucket cylinder and quick coupler system **A** from the attachment bolt **B**.
  -

## Inadmissible work procedures

---

### **NOTICE**

Inadmissible operation can damage the vehicle or the attachment.

---

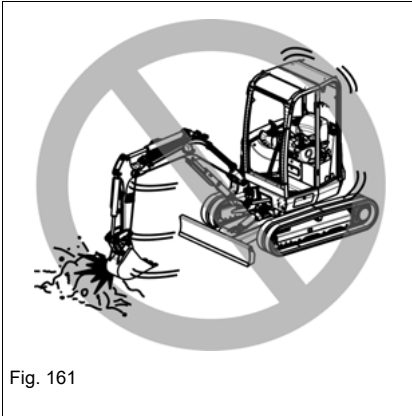

#### **Working with the swivel force**

Do not use the swivel force of the upper carriage to tear down walls or to create level surfaces.

Do not ram the attachment into the ground when swiveling the upper carriage.

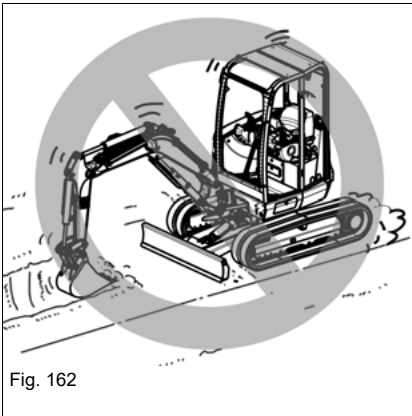

#### **Working with the drive force**

Do not ram the attachment into ground or lower the boom during vehicle travel.

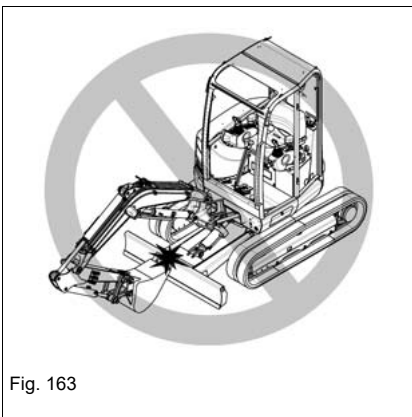

#### **Retracting the attachment**

When retracting the attachment, ensure that it does not touch the stabilizer blade.

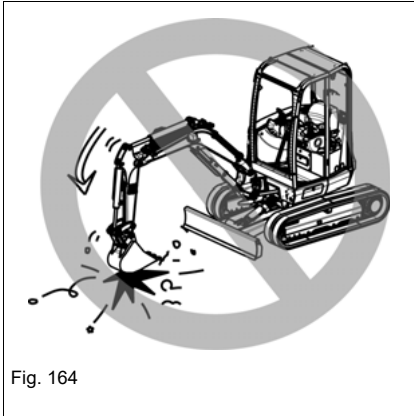

Fig. 164

**Working with the falling force by lowering the attachment**

Do not use the falling force of the attachment as a hoe, hammer or pile-driver.

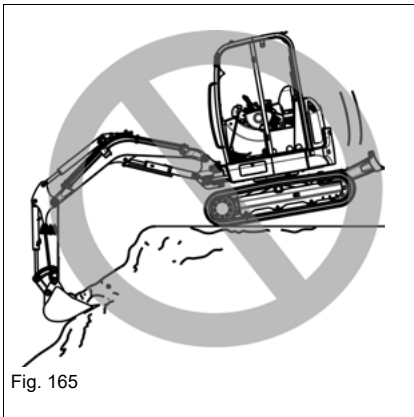

Fig. 165

**Working with the falling force by lowering the vehicle**

Do not use the dead weight of the vehicle for work.  
Use the force of the hydraulic cylinders exclusively.

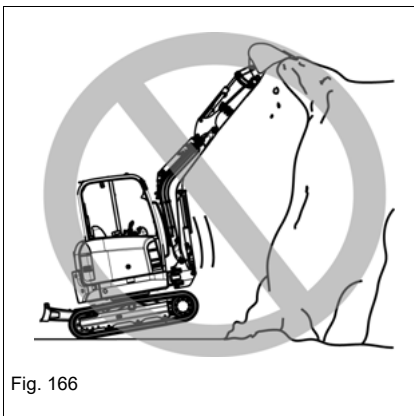

Fig. 166

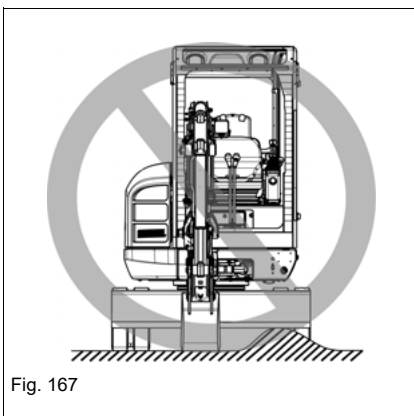

Fig. 167

**Fully lowering the stabilizer blade**

Apply the full weight of the vehicle over the entire width of the stabilizer blade when using it for stabilization.

**Protecting the stabilizer legs/blade against shocks**

The stabilizer blade or stabilizer blade cylinder can be damaged when the stabilizer blade hits against obstacles.



## General information regarding work operation

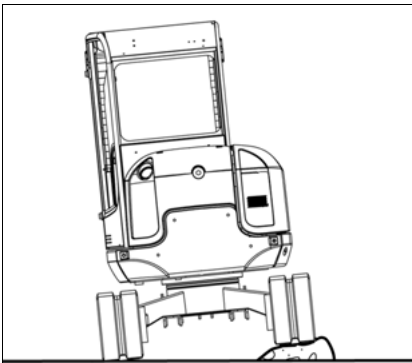

Fig. 168 (symbolic representation)

### Machine travel

Performing vehicle travel over obstacles can put a heavy load on the undercarriage and cause damage. Avoid performing vehicle travel over obstacles if possible.

If it cannot be avoided, lower the boom to ground level and travel over the obstacle at low speed.

### Traveling in speed range 2

Avoid starting vehicle travel and stopping abruptly as well as changing direction suddenly on rough terrain.

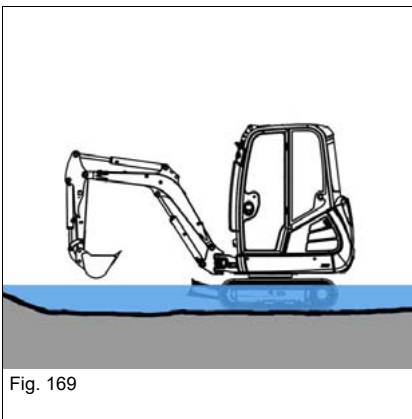

Fig. 169

### Operation in water

Water must not reach any further than the upper edge of the tensioning wheel.

Lubricate lubrication points again that were immersed in water for a longer time in order to expel the old grease.

Do not immerse the live ring and upper carriage in the water.

Operation in salt water is prohibited.

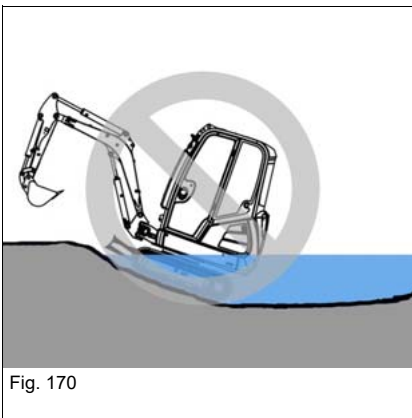

Fig. 170

Do not immerse the live ring and upper carriage in the water.

### Operation near the sea

Clean the vehicle regularly when using it in a saline environment.

See chapter **Cleaning and maintenance**.

## Working with the bucket

The following section describes work operations with the vehicle equipped with a backhoe bucket. The backhoe bucket is mainly used for earth-moving applications (digging, loosening, picking up and loading loose or solid material).

Place the stabilizer blade on the side you want to dig.

### Bucket position when digging

Perform long, level excavation movements with the stick and the bucket. The maximum excavation force is achieved at an angle of 80 to 120° between the boom and the stick.

1. Penetrate into the ground with the bucket.
2. Lower the stick and at the same time, position the bucket so that the flat lower side of the bucket is parallel with the ground.
3. Move the stick toward the vehicle and tilt in the bucket at the same time.

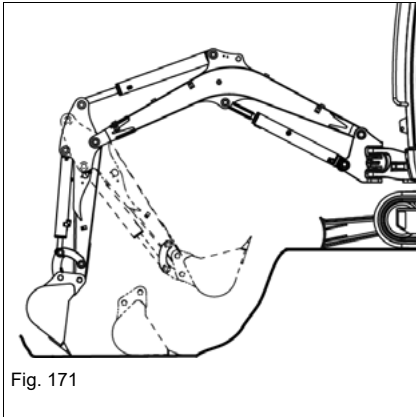

Fig. 171

### Working alongside trenches

For a more efficient working method, install a suitable bucket and set the tracks parallel to the trench.

When digging wide trenches, dig the side sections first and then the middle section.

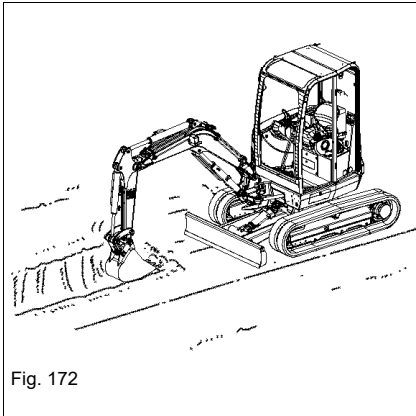

Fig. 172

For excavating laterally in tight spaces, turn the upper carriage and swivel the boom.

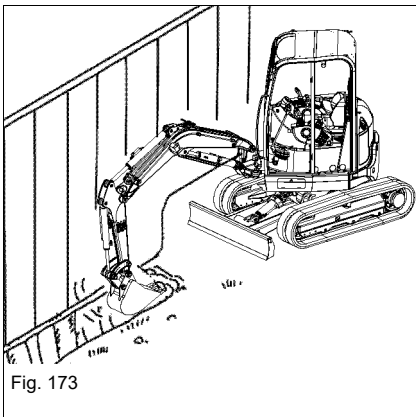
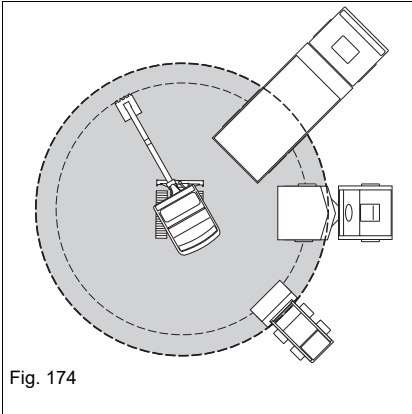

Fig. 173



### Loading material

Notes on loading site dumpers:

- Position the site dumper so that its cabin is outside the danger zone of the excavator.
- The loading platform of the truck is loaded by starting at the rear end.
- Keep the swivel angle as small as possible.
- Raise the full bucket to dump height only as you rotate toward the site dumper.
- Tilt out dusty material with the wind behind you to keep the dust away from your eyes, air filters and fans.
- If possible, the site dumper and the working direction of the bucket should form an angle of 45°.

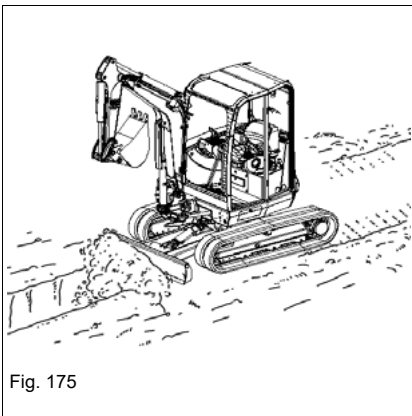

### Grading

The stabilizer blade is used for filling up trenches or grading the ground.

Lower the stabilizer blade to the ground for grading work.

Set the depth of the layer you want to remove with the stabilizer-blade lever.

- ➔ The vehicle must not be raised by lowering the stabilizer blade.
- ➔ Do not dig in the vehicle or let it sink in.

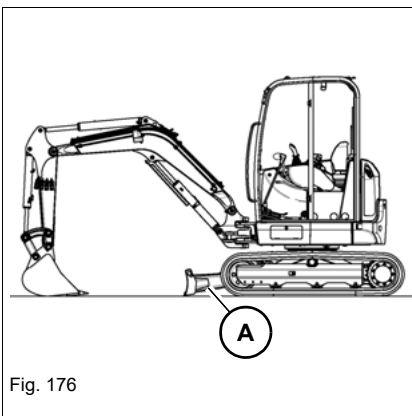

### Digging position

Place dozer blade **A** on the side you want to dig.

### Working on slopes

#### **WARNING**

##### **Vehicle tipping hazard on slopes!**

A tipping vehicle can cause serious injury or death.

- ▶ Secure slopes before beginning work. Pay attention to ground conditions, vehicle weight, etc.
- ▶ Stabilize the vehicle with the stabilizer blade during excavation work.

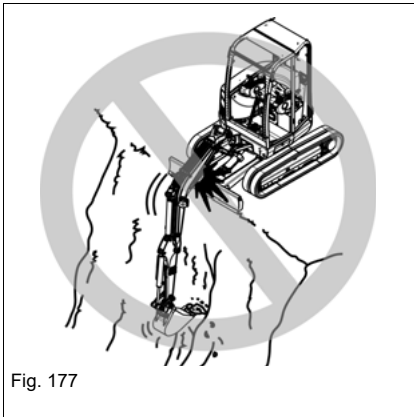

Fig. 177

#### **NOTICE**

Lifting arm cylinders can be damaged by improper operation.

- ▶ The piston rod must not touch the stabilizer blade.

#### Further **recommendations for digging**

When planning and performing digging work, Wacker Neuson recommends that you observe the following points:

- Exits from pits must be outside the digging line and as level as possible.
- Dig by removing side-by-side strips if possible.
- Ensure that you can drive forward when driving out of the digging area with a fully loaded bucket.
- Perform transport trips downhill with loaded bucket in reverse operation.

#### **Freeing the machine**

If the vehicle gets stuck in the ground:

- Tilt out the bucket until the blade is vertical above the ground.
- Lower the boom all the way.
- Slowly tilt out the bucket.
  - ▶ The vehicle is pushed backward.
- Reverse slowly.
- Repeat this procedure until the tracks reach firm ground.
- Reverse the vehicle away.

## 5.13 Emergency lowering

---

 **WARNING****Crushing hazard during boom lowering!**

Causes serious crushing or injury resulting in death.

- ▶ Do not allow anyone to stay in the danger zone.
  - ▶ Stop vehicle operation immediately as soon as someone enters the danger zone.
- 

Observe the following during emergency lowering:

1. Turn the starting key to position **1**.
  2. Lower the control lever base.
  3. Lower the boom completely.
  4. Return the joystick to neutral.
- 

 **Information**

Lower the boom immediately after stopping the engine.

---

## 5.14 Options

### Immobilizer

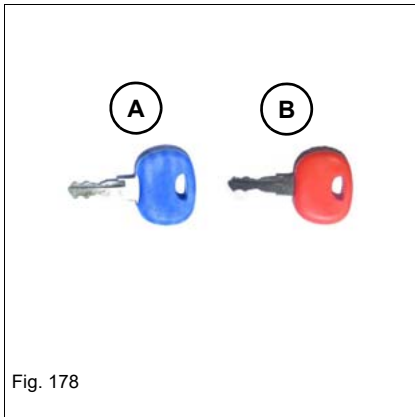

Fig. 178

**A** = starting key (blue)

For starting the vehicle. Scope of delivery includes 2 keys.

**B** = master key (red)



#### Information

Store the master key in a safe place. It can only be used for coding new starting keys.

A new immobilizer must be installed if the master key is lost.

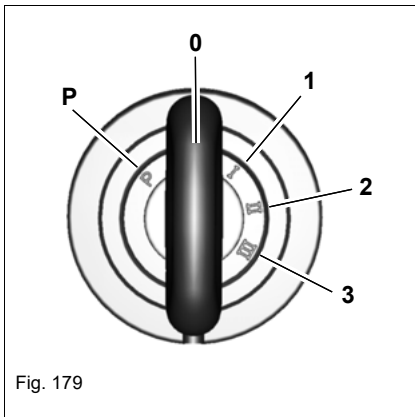

Fig. 179

#### Coding new starting keys

1. Insert master key **B** in the starter and turn it to position **1** for a maximum five seconds.
2. Remove master key **B**.
3. Keep master key **B** at least 50 cm (20 in) away from the starter.
4. Within 15 seconds, turn starting keys requiring coding to position **1** for at least one second.
5. Repeat step 4 if more starting keys require coding.
  - With this the coding of the starting keys is completed.

Coding can be performed for a maximum of 10 starting keys.



#### Information

The procedure is automatically canceled if no key requiring coding is detected by the system within 15 seconds.

#### Deleting coded keys

Deleting all coded keys is necessary whenever a coded key is lost.

The master key code is not deleted during deletion.

1. Insert master key **B** in the starter and turn it to position **1** for at least 20 seconds.
2. Code the starting keys.

## Tilt the superstructure with VDS

VDS can be used to tilt the upper carriage by up to 15° so that vertical excavation can be carried out on uneven ground conditions.

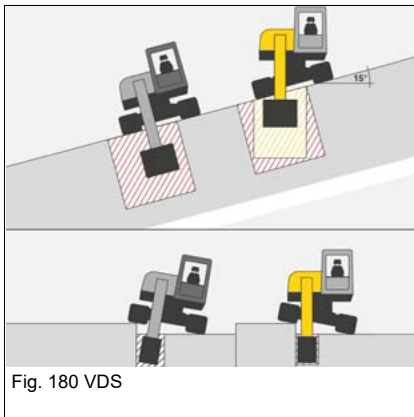

### **WARNING**

#### **Injury hazard due to movements of the upper carriage!**

Can cause serious injury or death.

- ▶ Do not allow anyone to stay in the danger zone.
- ▶ Only tilt upper carriage on the uphill side of the vehicle.
- ▶ Only tilt the upper carriage on firm ground.
- ▶ Tilt the upper carriage only if the vehicle is at a standstill and if the attachment is empty.
- ▶ Carry out quiet and slow movements with the vehicle, the arm system and the attachments.
- ▶ Do not perform machine travel on slopes with a lateral angle of inclination over 10°.
- ▶ Do not perform vehicle travel on inclines or slopes steeper than 15°.
- ▶ Ensure that no parts of the body protrude outside the vehicle.
- ▶ Do not board or leave the vehicle if the upper carriage is inclined.

### **NOTICE**

Tipping hazard of machine. Damage to the vehicle due to open doors and covers or collisions with walls or parts of buildings.

- ▶ Carry out quiet and slow movements with the vehicle, the arm system and the attachments.
- ▶ All doors and covers must be closed when tilting the machine.
- ▶ Only tilt the upper carriage on firm ground.
- ▶ Tilt the upper carriage only if the vehicle is at a standstill and if the attachment is empty.
- ▶ Do not perform machine travel on slopes with a lateral angle of inclination over 10°.
- ▶ Do not perform vehicle travel on inclines or slopes steeper than 15°.
- ▶ Only tilt upper carriage on the uphill side of the vehicle.
- ▶ Avoid collisions with walls or building parts.

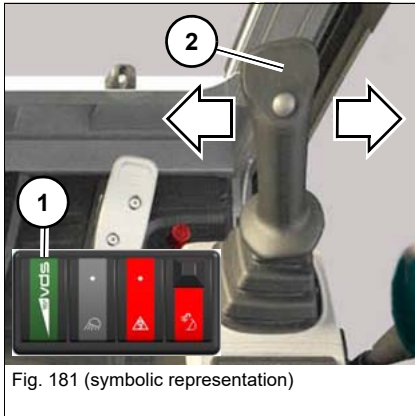

### Raise the upper carriage:

1. Press and hold the switch **1**.
2. Press control lever **2** to the right.
  - The superstructure lifts.
3. If the required tilt angle is reached, return joystick **2** to the neutral position and release switch **1**.

### Lower the upper carriage:

1. Press and hold the switch **1**.
2. Press control lever **2** to the left.
  - The superstructure lowers.
3. If the required tilt angle is reached, return joystick **2** to the neutral position and release switch **1**.

## Shovel bucket operation

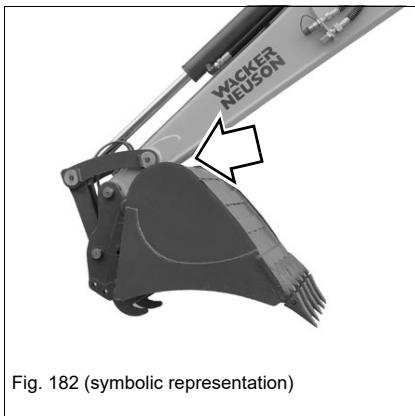

---

### **NOTICE**

The stick can be damaged if it is hit by the bucket base.

- ▶ Do not tilt out the bucket completely if it is used as a shovel bucket.
- 

## Trailer operation

The vehicle is not certified for trailer operation!



## 5.15 Immobilization/putting back into operation

The specified measures refer to putting the vehicle out of operation and back into operation after more than 30 days.

### Putting out of operation temporarily

Store the vehicle indoors if possible.

If the vehicle has to be stored outdoors, place it on firm ground if possible (for example on concrete), and cover it with a watertight tarp to protect it against humidity.

1. Park the vehicle – *see "Parking the vehicle" on page 5-9.*
2. Clean the engine with a high-pressure cleaner in a suitable place – *see chapter "7.5 Cleaning and maintenance" on page 7-18.*
3. Check the vehicle for leaks and loose nuts, screws and connections.
4. Carefully clean and dry the entire vehicle.
5. Spray an anti-corrosion agent onto bare metal parts of the vehicle (piston rods of hydraulic cylinders, for example).
6. Apply grease to all lubrication points.
7. Fill the fuel tank completely.
8. Check the hydraulic oil and coolant levels, and add hydraulic oil and coolant if necessary.
9. Remove the battery and store it in a safe place. Charge the battery and perform battery maintenance at regular intervals.
10. Close the air-intake openings of the air filter system and exhaust pipe.

### Putting back into operation

---

#### **Information**

If the vehicle was out of operation over a longer period of time without performing the specified steps, contact a Wacker Neuson service center before putting back into operation.

---

1. Perform a general visual check for damage on the electric cables, connectors, fuel lines, corrosion, etc. on the engine.
2. Start the engine once a month to ensure optimal lubrication.
3. Remove anti-corrosion agents from bare metal parts.
4. Charge, install and connect the battery.
5. Open the air-intake openings of the air filter system and exhaust pipe.
6. Check the condition of the air filter elements and have them replaced by a Wacker Neuson service center if necessary.
7. Check the dust valve.
8. Bleed the fuel system – see *"Fuel filter" on page 7-25*.
9. Check the vehicle for leaks.
10. Lubricate the vehicle according to the lubrication plan.
11. Check all engine/vehicle fluids in the units or reservoirs, and add fluids if necessary.
12. If the vehicle was out of service for over 6 months, have the oil in the gearbox, engine, hydraulic oil reservoir and other units changed by a Wacker Neuson service center.
13. Have the hydraulic oil filters (pressure, return and breather filters), the engine oil filter and diesel filter (prefilter and main filter) by a Wacker Neuson service center if the vehicle was out of operation for over 6 months.
14. Switch on the starter and check whether there are any malfunctions.  
– see *"Troubleshooting" on page 8-1*  
Contact an authorized service center and have the malfunction rectified.
15. Start the engine.
16. Let the engine run at idling speed at least 15 minutes without load.
17. Stop the engine
18. Check the oil levels in all units and add oil if necessary.
19. Check the vehicle for leaks.
20. Start the engine and ensure that all functions and warning systems work correctly.

Avoid operation at maximum engine speed or load for more than an hour.

## 5.16 Permanently putting out of operation

### Disposal

All fluids, lubricants, material, etc., used on the vehicle are subject to specific regulations. Dispose of different materials and consumables separately and in an environmentally friendly manner.

Disposal may only be performed by a Wacker Neuson service center. Observe the national and regional regulations for disposal.

---



### **Environment**

Do not allow environmentally damaging wastes to get into the ground or stretches of water and dispose of them in an environmentally friendly manner.

---

If the vehicle is no longer used according to its designated use, ensure that it is put out of operation and disposed of according to national and regional regulations.

- Machine disposal must be performed in accordance with state-of-the-art standards that apply at the time of disposal.



Notes:

## 6 Transportation

### 6.1 Towing the vehicle

---

 **WARNING****Accident hazard due to incorrect towing!**

Incorrect towing can cause accidents and serious injury or death.

- ▶ Tow the vehicle away only from the immediate danger zone until it can be loaded.
  - ▶ Only tow the vehicle using suitable towing equipment in connection with suitable towing facilities, such as towing hooks, eyes, etc.
  - ▶ There must be nobody between the vehicles during towing. The lateral safety distance is equal to 1.5 times the length of the towing equipment.
  - ▶ Do not tow the vehicle if it is stuck or on a slope. Load the vehicle.
  - ▶ Wear protective equipment.
  - ▶ Start vehicle travel and tow away slowly.
- 

**NOTICE**

The vehicle can be damaged during towing.

- ▶ Tow the vehicle away only from the immediate danger zone until it can be loaded.
  - ▶ Tow away the vehicle only if the engine is running and if the drive is functional.
  - ▶ Do not tow the vehicle if it is stuck or on a slope. Load the vehicle.
  - ▶ Only tow the vehicle using suitable towing equipment in connection with suitable towing facilities, such as towing hooks, eyes, etc.
  - ▶ A tractor vehicle of the same weight category must be used as a minimum.  
In addition, the tractor vehicle must be equipped with a safe braking system and sufficient tractive power.
- 

 **Information**

The manufacturer's warranty shall not apply to accidents or damage caused by loading or transporting.

---

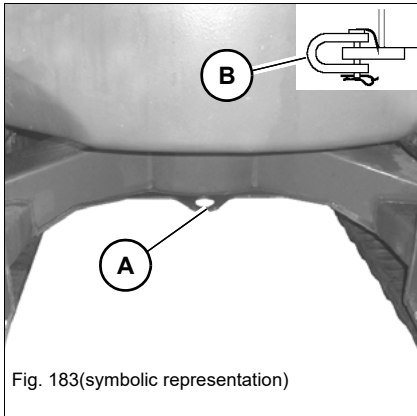

1. – see chapter “Towing” on page 2-13
2. Ensure that the vehicle can be towed safely.
3. Only use towing eye **A**.
4. Start vehicle travel and tow away slowly.
5. Secure shackle **B** with the shackle pin and a lock pin.
6. Install slings of appropriate size on the shackle.
7. Tow the vehicle only until it reaches a position from where it can be loaded.

### Information

The manufacturer’s warranty shall not apply to accidents or damage caused by towing.

Using the towing eye **A** to pull another vehicle or to tow equipment is prohibited.

## 6.2 Loading the vehicle

### WARNING

#### Accident hazard due to incorrect loading!

Incorrect loading can cause accidents and serious injury or death.

- ▶ Do not allow anyone to stay in the danger zone.
- ▶ Bear in mind the transport weight on the vehicle’s type label.
- ▶ Tie down the vehicle only at the indicated tie-down points.
- ▶ Observe the loading weight. Add the weight of subsequently installed accessories to the weight of the vehicle.

## Tie-down points

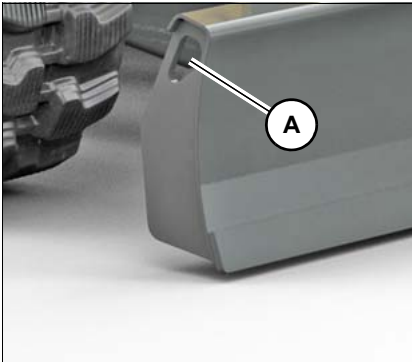

Fig. 184 (symbolic representation)

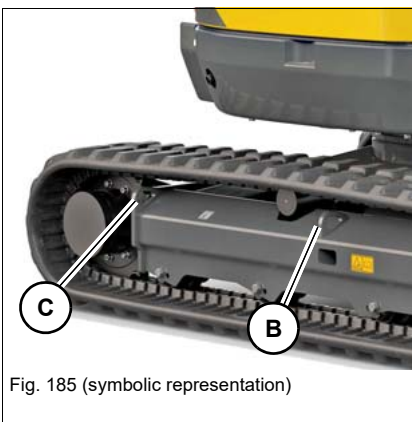

Fig. 185 (symbolic representation)

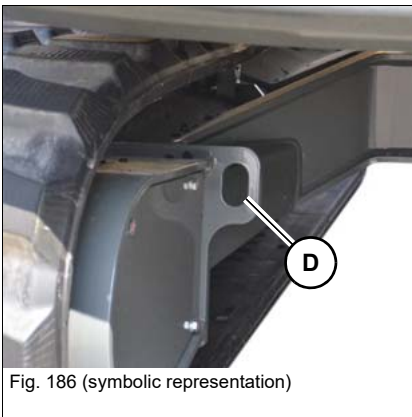

Fig. 186 (symbolic representation)

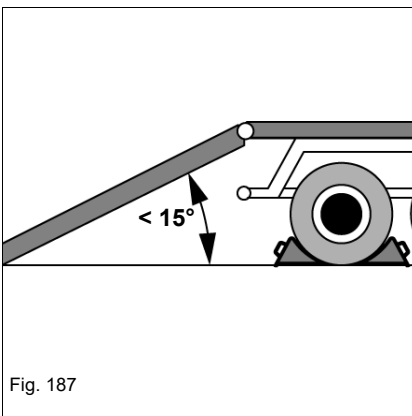
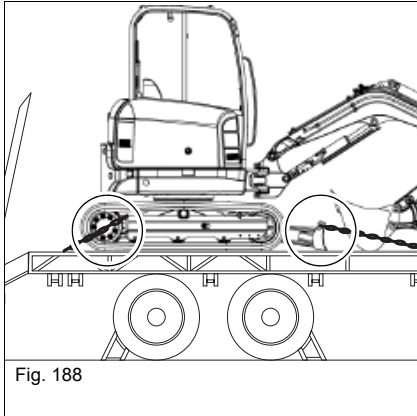

Fig. 187

Position		Quantity
<b>A</b>	Stabilizer blade	2
<b>B</b>	Front of travel gear	2
<b>C</b>	Rear of travel gear	2
<b>D</b>	Inside of travel gear	2

1. – see chapter “*Transportation*” on page 2-15
2. Secure the transport vehicle with chocks to prevent it from rolling.
3. Install access ramps at the smallest possible angle. Ensure that the grade does not exceed 15° (27%).
4. Use access ramps and transport surfaces with an anti-skid surface only.
5. Ensure that the loading area is clear and access to it is not obstructed, for example by superstructures.



6. Start the engine.
7. Raise the boom and the stabilizer blade to avoid touching the access ramps.
8. Carefully drive the vehicle onto the middle of the transport vehicle.
9. Move the vehicle to transport position:
  - Position the boom straight ahead at the center of the vehicle.
  - Lower the boom and the stabilizer blade.
10. Stop the engine
11. Raise the control lever base.
12. Remove the starting key and carry it with you.
13. Leave the cab, close and lock all doors, windows and covers.
14. Firmly secure the vehicle on the loading area with tie-down points with sling gear of appropriate size. Observe the legal regulations.



**Crane-lifting**

---

 **WARNING****Accident hazard due to incorrect loading!**

Incorrect loading can cause accidents and serious injury or death.

- ▶ Do not allow anyone to stay in the danger zone.
  - ▶ Bear in mind the transport weight on the vehicle's type label.
  - ▶ Observe the loading weight. Add the weight of subsequently installed accessories to the weight of the vehicle.
  - ▶ The vehicle may only be raised with suitable lifting gear.
- 

**NOTICE**

Possible damage to the vehicle due to incorrect loading.

- ▶ Bear in mind the transport weight on the vehicle's type label.
  - ▶ Observe the loading weight. Add the weight of subsequently installed accessories to the weight of the vehicle.
  - ▶ The vehicle may only be raised with suitable lifting gear.
-

**Lifting eyes**

The vehicle must only be raised using the lifting eyes indicated below.

**A:** Left and right lifting eyes on stabilizer blade

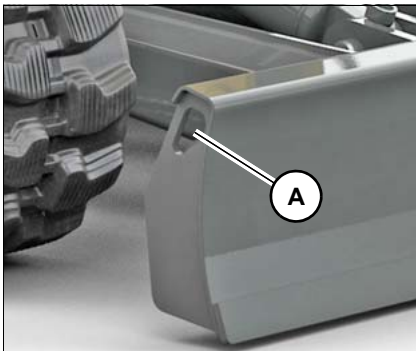

Fig. 189 (symbolic representation)

**B:** boom lifting eye

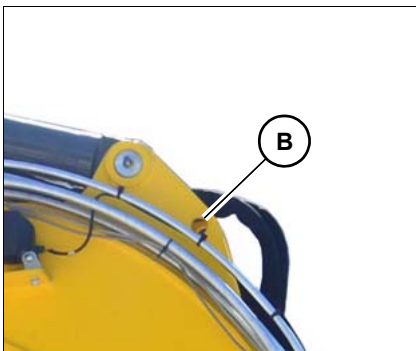

Fig. 190 (symbolic representation)

Ensure that the lifting gear has the required lengths **L1** and **L2**

Length	Dimensions
L1	1850 mm (73 in)
L2	3400 mm (11'-2")

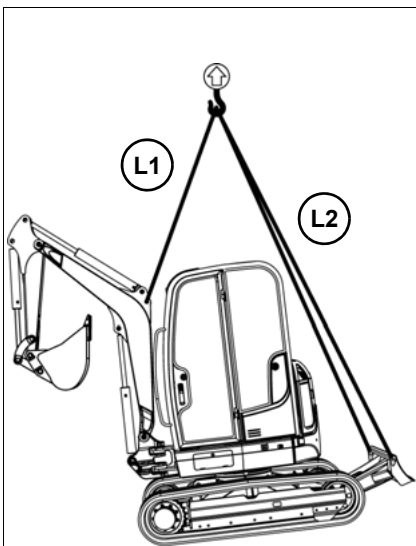
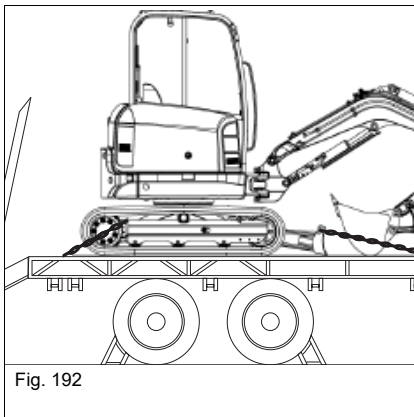

Fig. 191

### Loading process

1. Fit an empty bucket and lock it safely.
2. Remove all dirt from the vehicle.
3. Park the vehicle on firm, level, and horizontal ground.
4. Tilt in bucket.
5. Raise the loader unit completely.
6. Pull the stick toward the vehicle.
7. Raise the stabilizer blade completely.
8. Position the boom straight ahead at the center of the vehicle.
9. Rotate the upper carriage by 180° so that the stabilizer blade points to the rear.
10. Stop the engine
11. Raise the control lever base.
12. Remove the starting key and carry it with you.
13. Safely store all loose objects.
14. Leave the cab, and close and lock the vehicle doors, windows and covers.
15. Attach slings on the lifting eyes.
16. Slowly raise the vehicle until there is no more contact with the ground.
17. Let the vehicle swing until it comes to rest.
18. If the vehicle balance, and the condition and position of the slings is correct, slowly raise the vehicle to the required height and load it.

## 6.3 Transporting the vehicle



1. The driver of the transport vehicle must observe the following before departure:
  - Permitted overall height, width and weight of the transport vehicle including the excavator.
  - The legal regulations of the countries where transport is to take place.
2. Close the exhaust pipe before transporting the vehicle through wet weather.

### Information

The automatic swivel unit brake secures the upper carriage against rotation.



Notes:

## **7 Maintenance**

### **7.1 Information on maintenance**

- Maintenance and care significantly affect the functionality and service life of the vehicle.
- Daily and weekly maintenance work is to be performed by the driver in accordance with the maintenance plan.
- Maintenance with the note **authorized service center** must be performed only by the trained and qualified personnel of an authorized service center.
- Defective components must be repaired or replaced before putting the vehicle into operation. Safety-relevant components may only be repaired/replaced by an authorized service center.
- Observe all risk indications and safety instructions given in this Operator's Manual.
- Follow the maintenance and safety instructions given in the Operator's Manuals of the attachments.
- Wear protective equipment (for example hard hat, safety glasses, protective gloves, safety boots).
- Attach a warning label to the control elements (for example "**Machine being serviced, do not start**").
- Stop the vehicle (see **Preparing lubrication**).
- In order to avoid damage to electronic components, do not perform welding work on the vehicle, add-on parts or tools.
- Contact a Wacker Neuson service center.

## 7.2 Maintenance overview

### Maintenance label

Maintenance that has to be performed by the operator is indicated on the maintenance label.

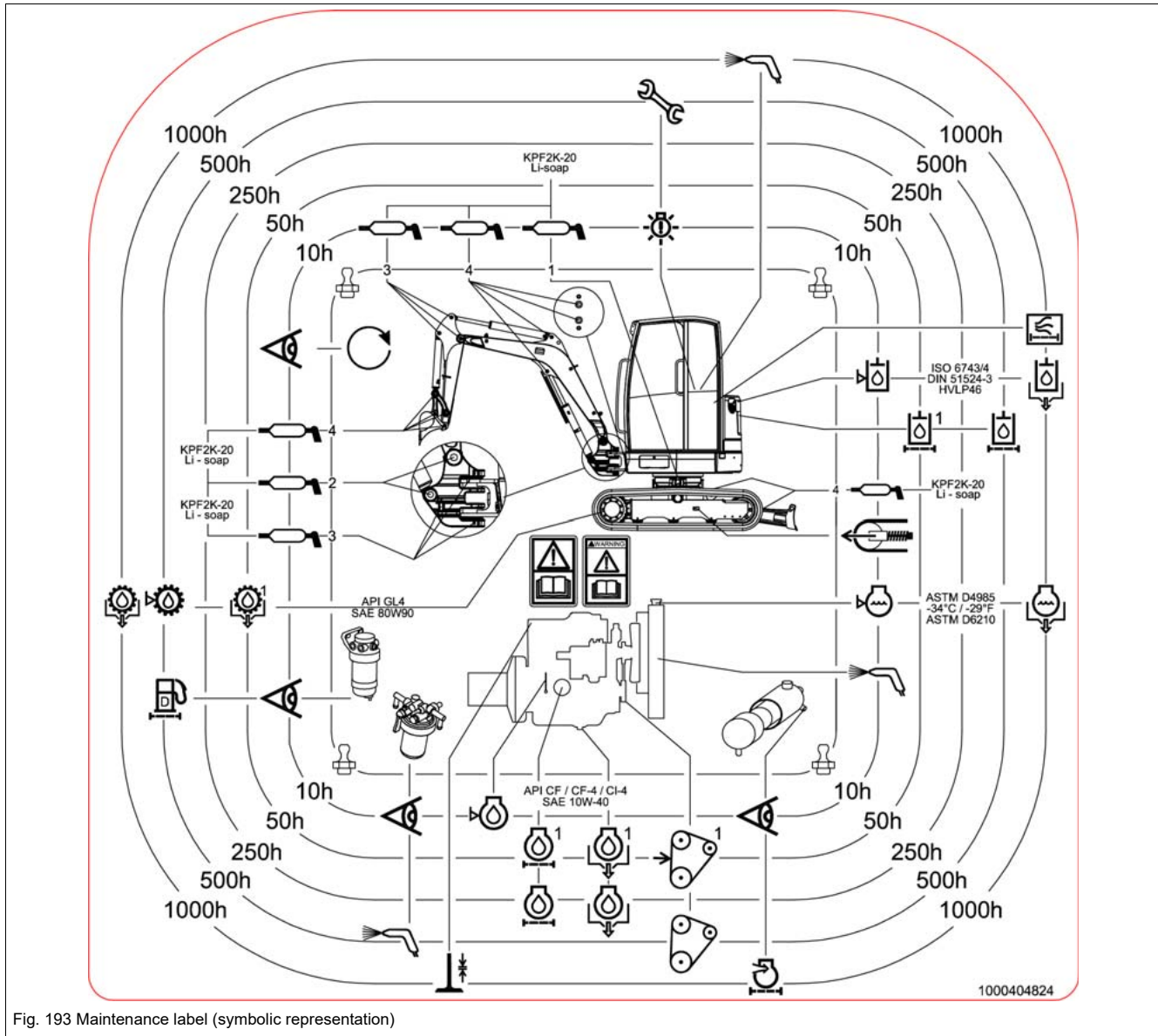

Fig. 193 Maintenance label (symbolic representation)

I = Top off and drain fluids, lubricants; Check vehicle functions.

















II = Check wear parts, seals, hoses, and screw connections.













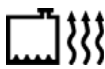

III = Check for damage, corrosion, and dirt.

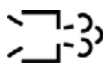
IV = Lubricate daily after the work shift.



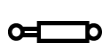



Superscript numbers, for example <sup>2</sup>: number of lubrication points

**Maintenance plan**

<b>Daily maintenance (operator)</b>		
<b>Symbol</b>	<b>Inspection work</b> (Check the following fluids and lubricants, check the oil levels after a test run and add oil if necessary)	<b>Page</b>
	Check the fluids and lubricants (engine oil, engine coolant, hydraulic oil)	<a href="#">7-29</a> ; <a href="#">7-31</a> ; <a href="#">7-37</a>
	Check the radiator and hydraulic oil cooler for dirt, clean them if necessary	<a href="#">7-32</a>
	Lubricate the vehicle according to the lubrication schedule	<a href="#">7-7</a>
	Check the dirt indicator on the air filter	<a href="#">7-33</a>
	Check the water separator and fuel filter on sight glass; drain water if necessary	<a href="#">7-25</a>
	Check the track tension and retension the tracks if necessary	<a href="#">7-42</a>
	Check the engine air intake	<a href="#">7-33</a>
	Check the pin locks	--
	Check line fixtures	--
	Check the indicator lights and acoustic warning devices	<a href="#">4-28</a> ; <a href="#">5-14</a>
	Check the swivel unit brake for correct function	<a href="#">5-19</a>
	Check the hydraulic couplings for dirt	--
	Check the threaded fittings of the protective structures (cabin, for example) for tightness	--
	Clean the lights/light system, signaling systems	--
	Safe load indicator: check the acoustic warning system	<a href="#">5-46</a>
	Hydraulic quickhitch (Easy Lock): check the acoustic warning system	<a href="#">5-28</a>

Daily maintenance (operator)		
	Lubricate the Powertilt according to the lubrication schedule	7-8
	Adjust the mirrors correctly, clean them and check them for damage, check the fastening screws and tighten them if necessary	--
<b>Leakage check</b>		
	Check for tightness, leaks and chafing: pipes, flexible lines and screw connections of the following assemblies and components. Repair if necessary	Page
	Engine and hydraulic system	--
	Travel drive	--
	Cooling systems, heating, and hoses (visual check)	--
	Hydraulic quickhitch (Easy Lock) and Powertilt (hoses, valve)	--
<b>Visual check</b>		
	Correct function; deformations, damage, surface cracks, wear and corrosion	Page
	Check the exhaust system for damage	--
	Check the insulating mats in the engine compartment for damage	--
	Check the cab and protective structures for damage (for example the Front Guard, FOPS)	--
	Check the tracks for damage	--
	Check the travel gear for damage (for example the track rollers, insert rolling bearings)	--
	Check the piston rods of the cylinders for damage	--
	Check the seat belt for damage	--
	Check the hydraulic hoses for damage	--
	Check the load hook, joint rod and lifting eyes	--



Daily maintenance (operator)		
	Check the hydraulic quickhitch (Easy Lock) for damage	--
	Check the Powertilt for damage	--
Weekly maintenance (every 50 operating hours) (operator)		Page
	Lubricate the vehicle according to the lubrication schedule	<a href="#">7-7</a>
	Check accesses and exits for dirt	--
	Replace the air filter <sup>1</sup>	--
	Actuate the Powertilt swivel device in the limit positions in both flow directions for one minute each to rinse the system	--
All steps for maintenance intervals once a day		--

1. Replace the air filter according to the multi-functional display, every 1000 o/h or once a year at the latest. When in extensive use in environments with acidic air (for example acid production facilities, steel and aluminum mills, chemical plants and other nonferrous-metal plants): replace after 50 o/h without regard to multi-functional display. Contact a Wacker Neuson service center.

Only once after the first 50 operating hours (Wacker Neuson service center)	
Change the engine oil	--
Replacing the engine oil filter	--
Replace the hydraulic oil filter	--
Replace the gearbox oil (traveling drive)	--
Check V-belt condition and tension	--
Check the threaded fittings for tightness	--
Check labels and Operator's Manual for completeness and condition	--
Reset the maintenance meter	--
All steps for maintenance once a day and once a week	--

**Other maintenance intervals (Wacker Neuson service center):**

- Every 250 operating hours
- Every 500 operating hours or annually
- Every 1000 operating hours
- Every 1500 operating hours

For additional details contact a Wacker Neuson service center.

**Information**

Maintenance with the note **authorized service center** must be performed only by the trained and qualified personnel of an authorized service center.

## Maintenance schedule of Lehnhoff mechanical quickhitch system

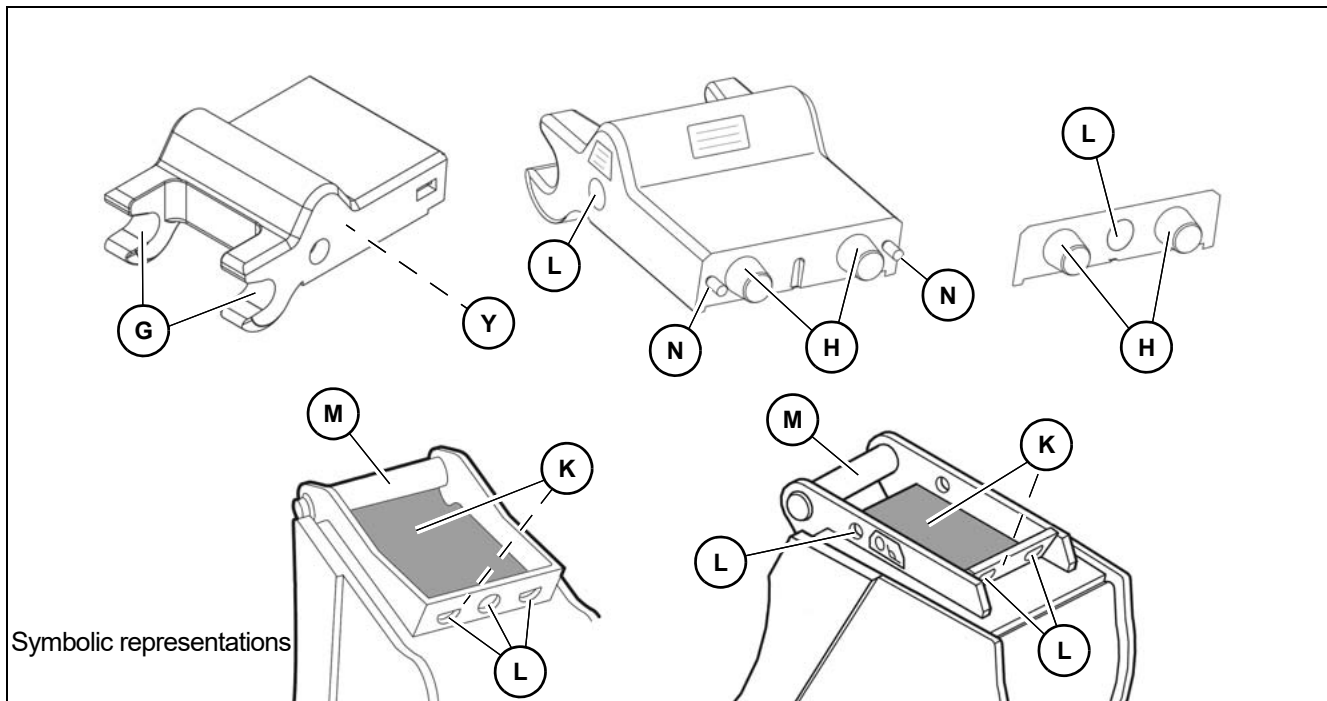

Quickhitch maintenance MS03/MS08/MS10 (operator)		Interval <sup>1</sup>
Perform visual inspection of the quickhitch system	--	10 hours of operation/ daily
Clean bolt guide	G	50 hours of operation/ weekly
Clean the bolt contact surface	H	50 hours of operation/ weekly
Clean bottom side of the quick coupler system	Y	50 hours of operation/ weekly
Clean contact surfaces of the attachment	K	50 hours of operation/ weekly
Clean the opening for the socket wrench and bores of the attachment support	L	50 hours of operation/ weekly
Clean bolt attachment support	M	50 hours of operation/ weekly
Clean centering pins (only MS10)	N	50 hours of operation/ weekly

1. For time specifications: the first achieved time specification is decisive. If the situation requires it, perform maintenance if necessary, even if the maintenance interval has not yet been reached.

### Other maintenance intervals (Wacker Neuson service center):

- Every 250 operating hours or semi-annually (MS03)
- Every 500 operating hours or annually (MS03)
- Every 500 operating hours or semi-annually (MS08/MS10)
- Every 1000 operating hours or annually (MS08/MS10)

For additional details contact a Wacker Neuson service center.

## Preparing lubrication

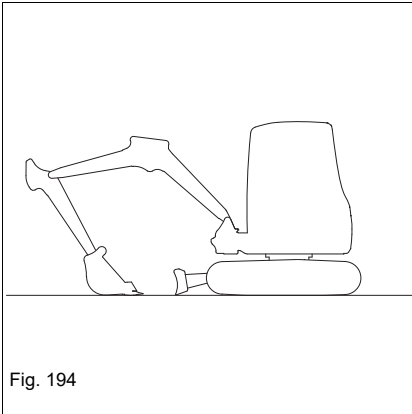

1. Stop the vehicle on firm, level, and horizontal ground.
2. Position the boom straight ahead at the center of the vehicle.
3. Lower the boom and the stabilizer legs to the ground.
4. Stop the engine
5. Operate the control lever repeatedly to release the pressure in the hydraulic system.
6. Raise the control lever base.
7. Remove the starting key and carry it with you.
8. Safely store all loose objects.
9. Close the windows and doors.
10. Close and lock all covers.
11. Attach a warning label to the control elements (for example “**Machine being serviced, do not start**”).

Wait at least 10 minutes after stopping the engine.



### **Information**

Keep all lubrication points clean and remove any escaping grease.

Lubrication plan

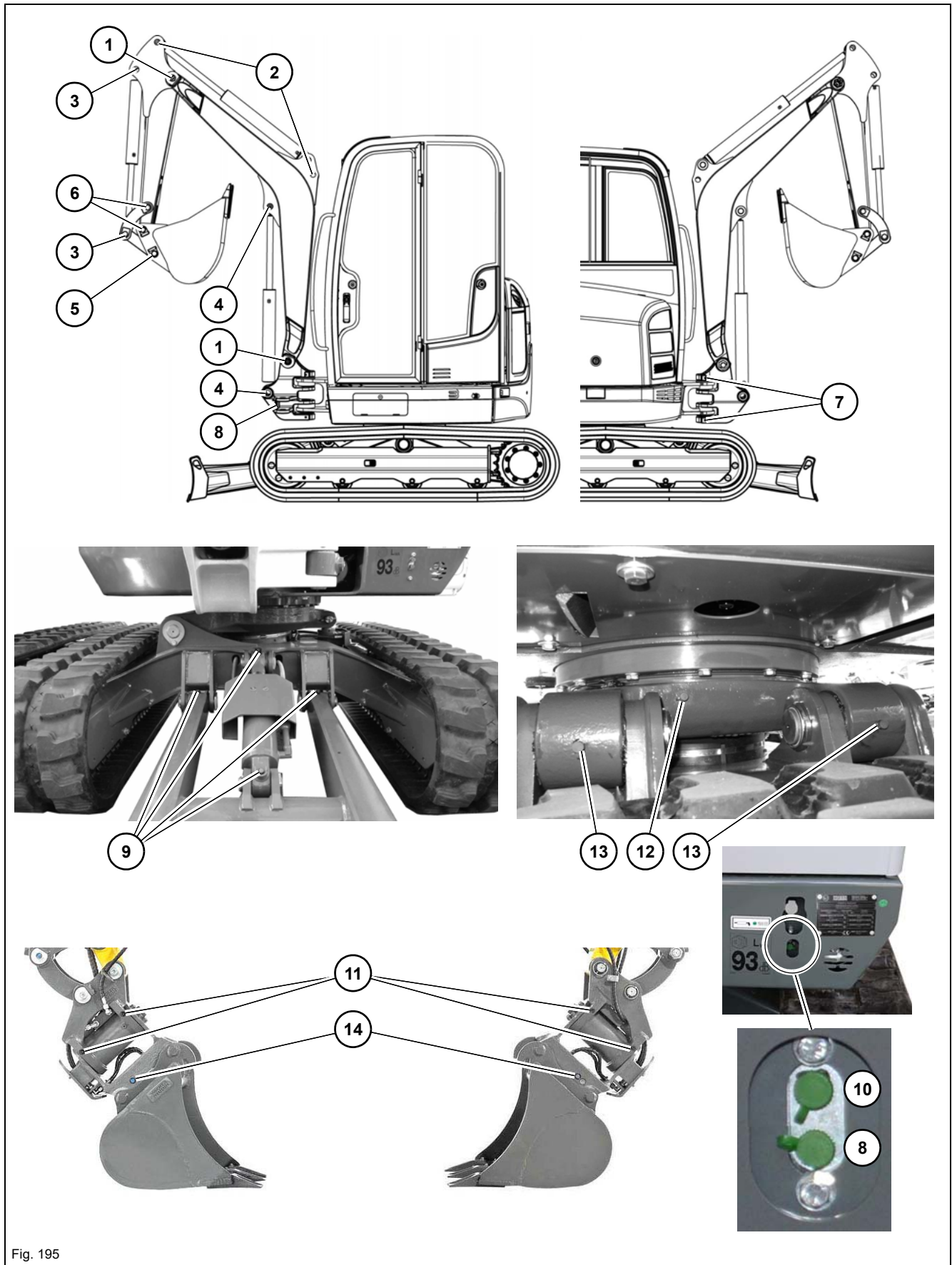
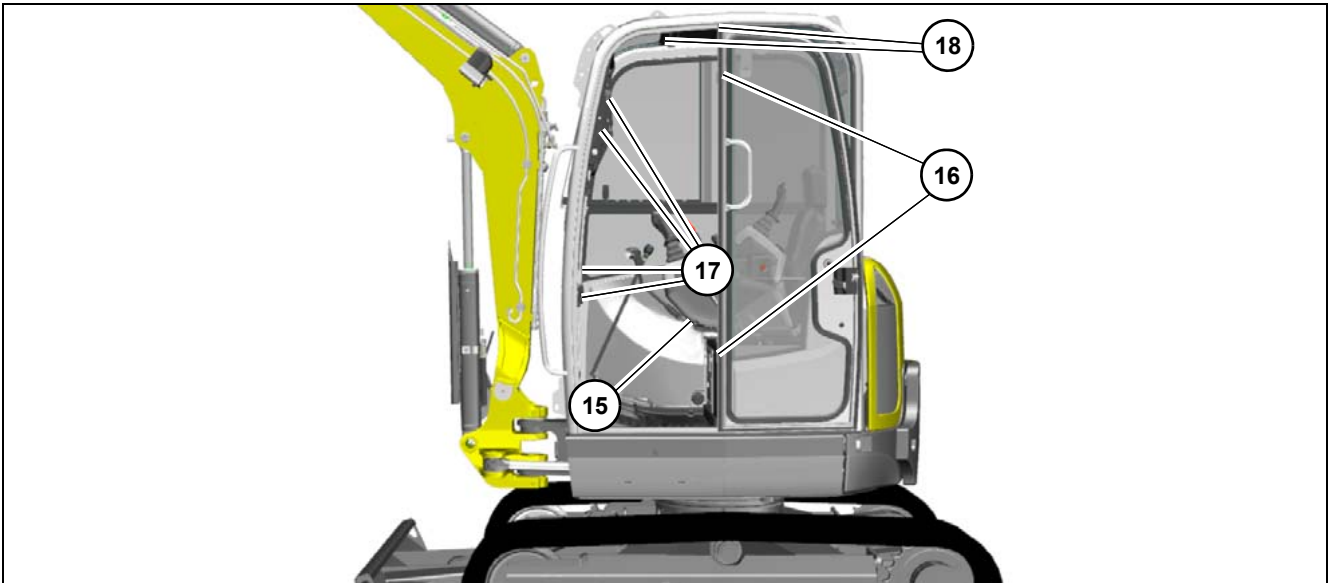

Fig. 195



Position	Lubrication point	Interval	Quantity
1.	Boom	Daily	2
2.	Stick cylinder	Daily	2
3.	Bucket cylinder	Daily	2
4.	Boom cylinder	Daily	2
5.	Joint rod	Daily	1
6.	Shovel arm	Daily	2
7.	Swiveling console	Daily	2
8.	Swiveling cylinder	Daily	2
9.	Stabilizer blade/cylinder	Daily	4
10.	Live ring (ball bearing)	Every week	1
11.	Powertilt	Daily <sup>12</sup>	4
12.	VDS live ring gear	Every week	1
13.	VDS	Every week	2
14.	Hydraulic quickhitch	Daily	2
	Attachment of the tool holder for the hydraulic quickhitch system	Every week	--
15.	Control lever base	Every week	3
16.	Door hinges	Every week	2
17.	Pin lock notch and lock	Every week	4
18.	Front window rail	Every week	2

1. 2 times a day when used in water; after use in water, lubricate grease nipples so that no water is left
2. The number and position of the greasing points depend on the Powertilt type

## Live ring (ball bearing)

### DANGER

#### Crushing hazard during lubrication!

Serious crushing hazard causing death or serious injury.

- ▶ No one must be in the danger zone during upper carriage rotation.
- ▶ Do not tilt the superstructure with the **VDS** option.

The lubrication points are located on the left on the superstructure.

1. Park the vehicle on firm, level, and horizontal ground.
2. Lower the boom and the stabilizer blade to the ground.
3. Stop the engine, remove the starting key and carry it with you.
4. Apply grease to lubrication point **A** with two strokes of the grease gun.

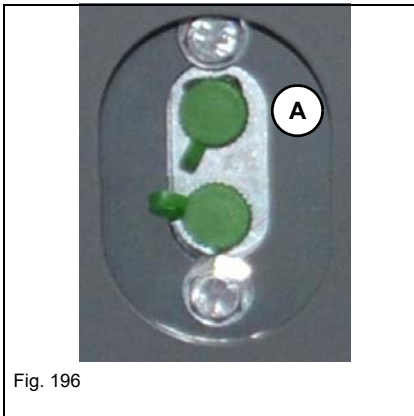

Fig. 196

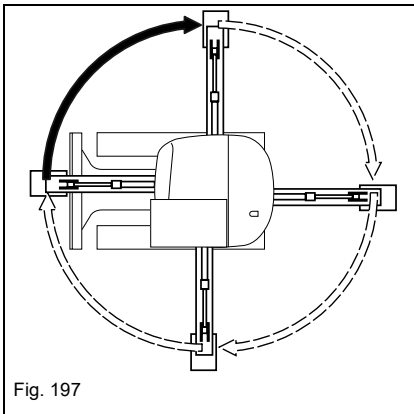

Fig. 197

5. Start the engine, raise the boom and the stabilizer blade.
6. Rotate the upper carriage by 90°.
7. Repeat steps 2-6 three times until the revolving upper carriage is back in its initial position.
8. Rotate the upper carriage several times by 360°.

**Teeth of live ring VDS**

**DANGER**
**Crushing hazard during lubrication!**

Serious crushing hazard causing death or serious injury.

- ▶ No one must be in the danger zone during upper carriage rotation.
- ▶ Do not tilt the superstructure with the **VDS** option.

The lubrication point is located at the right on the VDS console.

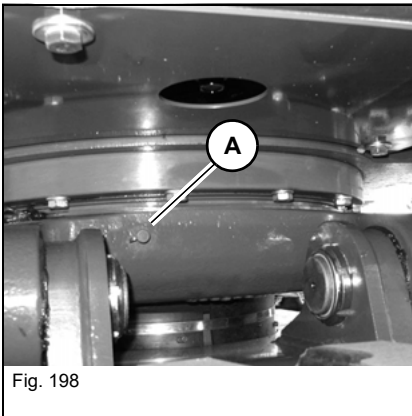

Fig. 198

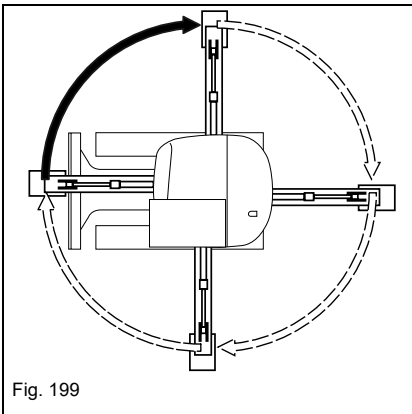

Fig. 199

1. Park the vehicle on firm, level, and horizontal ground.
2. Lower the boom and the stabilizer blade to the ground.
3. Stop the engine, remove the starting key and carry it with you.
4. Apply grease to lubrication point **A** with two strokes of the grease gun.
5. Start the engine, raise the boom and the stabilizer blade.
6. Rotate the upper carriage by 90°.
7. Repeat steps 2-6 three times until the revolving upper carriage is back in its initial position.

### Control lever base

---

 **CAUTION**

**Crushing hazard in the area of the moving parts of the control lever base!**

Injury hazard due to crushing of parts of body.

► Stay clear (extremities, clothing) of the moving parts.

---

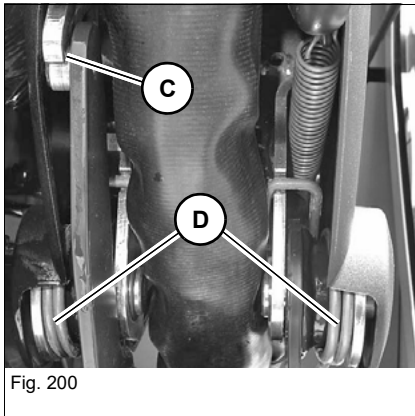

1. Raise the control lever base.
2. Spray fluid grease onto the guide lever in the area of **C**.
3. Spray fluid grease on both sides **D** of the double spring.

### Powertilt with Easy Lock – operation in water

- Apply grease to the lubrication points before using in water.
- After using in water, apply grease to the lubrication points to remove all water.



### 7.3 Fluids and lubricants

Application	Fluid/lubricant	Specification	Season/temperature	Capacities <sup>1</sup>
Engine	Diesel fuel <sup>2,3</sup>	ASTM D975 - 94: 1D 2D (USA)	Year-round <sup>4</sup>	36 liters (9.5 gal)
		EN 590 (EU)		
		ISO 8217 DMX (International)		
		BS 2869-A1, A2 (GB)		
		JIS K2204 (Japan)		
		KSM-2610 (Korea)		
	GB252 (China)			
Biodiesel	EN 14214			
	ASTM D-6751			
Coolant <sup>5</sup>	Distilled or deionised water and Fuchs Friconfin Maintain LL (orange)/Caltex DELO XLC (orange)	Year-round	4.5 liters (1.2 gal)	
Engine oil <sup>6</sup>	Fuchs Titan Truck Plus 15W-40/Caltex DELO Gold Ultra 15W-40	– see "Engine oil types" on page 7-15	About 3.4 l (0.9 gal)	
Hydraulic oil reservoir	Hydraulic oil <sup>7</sup>	Fuchs Renolin B 46 HVI Plus/Caltex RANDO MV 46 <sup>8</sup>	Year-round <sup>9</sup>	30 liters (7.9 gal)
Washer system	Cleaning agent	Glass cleaner and anti-freeze	Year-round	1.2 liters (0.3 gal)
Grease nipples	Roller and friction bearings	KPF 2 K-20 <sup>10</sup> ISO-L-X-BCEB 2 <sup>11</sup>	Year-round	As required
	Open transmissions live ring: ball bearing			
	Live ring gears			
	Grease nipples			
Battery terminals	Acid-proof grease <sup>12</sup>	FINA Marson L2	Year-round	As required
Control lever base	Adhesive fluid grease	Förch S401	Year-round	As required

- The capacities indicated are approximate values; the oil level check alone is relevant for the correct oil level. Capacities indicated are no system fills
- In countries where level IIIA (or higher) or Tier IV interim (or higher) exhaust emission regulations apply, use diesel fuels with a maximum sulfur content of 0.0015 % (= 15 mg/kg).
- Sulfur content below 0.05 %, cetane number over 45
- Summer or winter diesel depending on outside temperatures
- Do not mix engine coolant - check cooling compound table; contact authorized service center
- According to DIN 51511 (API CF, CF-4, CI-4; ACEA E3, E4, E5; JASO DH-1)
- According to DIN 51524 section 3, ISO-VG 46.
- Alternative hydraulic oil for high outside temperatures: Fuchs Renolin B 68 HVI Plus
- Depending on local conditions – see "Hydraulic oil types" on page 7-14.
- KPF 2 K-20 according to DIN 51502 lithium-saponified grease.
- ISO-L-X-BCEB 2 according to DIN ISO 6743-9, lithium-saponified grease.
- Standard acid-proof grease NGLI category 2.

## Hydraulic oil types

Viscosity class	Ambient temperature			
	min. °C	min. °F	max. °C	max. °F
ISO VG32	-20	-4	30	86
ISO VG46	-5	23	40	104
ISO VG68	5	41	50	122

### Replacement intervals

Replace the hydraulic oil and hydraulic oil filter depending on the percentage of hammer operation.

Percentage of hammer work	Hydraulic oil	Hydraulic oil filter
20 %	800 o/h	300 o/h
40%	400 o/h	
60%	300 o/h	100 o/h
Over 80%	200 o/h	

### Important information regarding operation with biodegradable hydraulic oil

- Use only the biodegradable oils that have been tested and released by Wacker Neuson.
- Add only biodegradable oil of the same type. In order to avoid misunderstandings, attach a clear label to the hydraulic oil filler neck providing clear information regarding the type of oil currently used. The joint use of two different biodegradable oils can affect the quality of one of the oil types. Therefore ensure that the remaining amount of biodegradable oil complies with the national and regional regulations. Observe the manufacturer's indications.
- Do not add mineral oil – the content of mineral oil should not exceed 2% of the system fill in order to avoid foaming problems and to ensure biological degradability.
- When running the vehicle with biodegradable oil, the same oil and filter replacement intervals are valid as for mineral oil.
- Always have the condensation water in the hydraulic oil reservoir drained by a Wacker Neuson service center before the cold season. The water content may not exceed 0.1% by weight.
- The instructions in this Operator's Manual concerning environmental protection are also valid for the use of biodegradable oil.
- Subsequent change from mineral oil to biodegradable oil may only be performed by a Wacker Neuson service center.

**Engine oil****Engine oil types**

Viscosity grade (SAE)	Ambient temperature			
	min. °C	min. °F	max. °C	max. °F
10W	-20	-4	10	50
20W	-10	14	10	50
10W40	-20	-4	40	104
15W40	-15	5	40	104
20	0	32	20	68
30	10	50	30	86
40	20	68	40	104



---

### 7.4 Maintenance accesses

---

 **WARNING**

**Injury hazard due to rotating parts!**

Rotating parts can cause serious injury or death.

- ▶ Open the engine cover only at engine standstill.
- 

 **CAUTION**

**Burn hazard due to hot surfaces!**

Can cause serious burns or death.

- ▶ Stop the engine and let hot surfaces cool down.
  - ▶ Wear protective equipment.
- 

 **CAUTION**

**Injury hazard due to open maintenance access!**

Can cause injury.

- ▶ Take care to avoid injuries when the maintenance access door is open.
-

## Opening the engine cover



1. Stop and park the vehicle Stop the engine  
- See "**Preparing lubrication**".
  2. Turn the starting key in lock **A** anticlockwise.
  3. Press lock **A** and open the engine hood.
- The engine cover is supported by a gas strut.

## Close the engine cover

1. Firmly press down the engine cover.
2. Turn the starting key in lock **A** clockwise.

## Fuse boxes

– see chapter "9.8 Electrical system" on page 9-3

## Maintenance flap

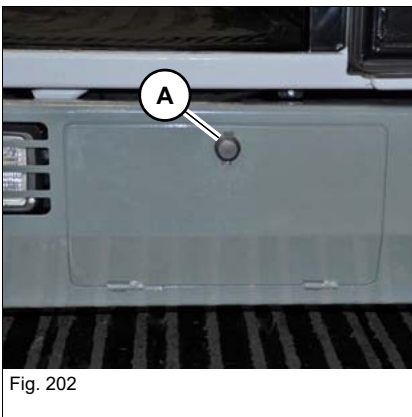

Behind the maintenance cover to the left on the chassis is the on-board tool kit.

### Unlocking:

Turn the starting key in lock **A** anticlockwise.

### Locking:

Turn the starting key in lock **A** clockwise.



### 7.5 Cleaning and maintenance

---

---

 **WARNING**

**Injury hazard due to rotating parts!**

Rotating parts can cause serious injury or death.

- ▶ Open the engine cover only at engine standstill.
- 

---

 **WARNING**

**Burn hazard due to hot surfaces!**

Hot surfaces can cause serious burns or death.

- ▶ Stop the engine and let it cool down.
  - ▶ Wear protective equipment.
- 

---

 **CAUTION**

**Health hazard due to cleaning agents!**

Cleaning agents can be harmful to health.

- ▶ Use only suitable cleaning agents.
  - ▶ Ensure sufficient ventilation.
-

---

**NOTICE**

Damage to rubber and electrical parts when cleaning with solvents.  
Do not use solvents, benzine, or other aggressive chemicals.

---

---

**NOTICE**

Damage to electrical components due to water jet.

- ▶ Clean the vehicle only when the engine is switched off.
  - ▶ Electronic components (e. g. relays, displays) must not be cleaned with a high-pressure cleaner.
  - ▶ A distance of at least 50 cm (20 in) to the nozzle of the high-pressure cleaner must be maintained from electrical components (e. g. headlights, rotating beacons)
  - ▶ Carefully dry electrical components with compressed air and spray with contact spray.
- 

**Environment**

In order to avoid damage to the environment, clean the vehicle only in wash bays and places authorized by the authorities.

---

Cleaning the vehicle is divided into three separate areas:

- Inside the cabin
- Exterior of the vehicle
- Engine compartment

### **Washing solvents**

- Ensure sufficient room ventilation.
- Wear suitable protective clothing.
- Do not use flammable liquids, such as gasoline or diesel.

### **Compressed air**

- Work carefully.
- Wear safety glasses and protective clothing.
- Do not aim the compressed air at the skin or at other people.
- Do not use compressed air for cleaning your clothing.

### **High-pressure cleaner**

- Clean the vehicle only when the engine is switched off.
- Cover electrical components.
- Do not direct the water jet under covers.
- Cover tank caps and filters.
- Keep sufficient distance from labels.
- Protect sensitive components from moisture and do not clean with a high-pressure cleaner (examples):
  - Engine compartment, engine components, insulating material.
  - Electrical components (e. g. alternator, control units, connector plugs on the wiring harness)
  - Covers and seals
  - Air filter, exhaust

### **Volatile and easily flammable anti-corrosion agents and sprays:**

- Ventilate rooms well.
- Fire, open flames and smoking is prohibited.

## **Inside the cabin**

Recommended aids:

- Vacuum cleaner, broom
- Moist cloths
- Brush
- Water with mild soap solution

## **On the outside of the vehicle**

Recommended aids:

- High-pressure cleaner
- Steam jet



## **Engine compartment**

1. Park the vehicle in a wash bay or place suitable for washing.
2. Stop the engine See "**Preparing lubrication**".
3. Clean the vehicle.

## **Seat belt**

Always keep the seat belt clean, as coarse dirt can impair the proper functioning of the seat belt buckle.

Clean the seat belt (while it remains fitted in the vehicle) with a mild soap solution only. Do not use chemical agents as they can destroy the fabric.

## **Cleaning in a saline environment**

1. Park the vehicle in a wash bay or place.
2. See "**Preparing lubrication**".
3. Check the vehicle for salt deposits or corrosion. Have corrosion removed by a Wacker Neuson service center.
4. Clean the vehicle with a high-pressure cleaner. Clean the vehicle ensuring that there are no salt deposits in places that are difficult to access.  
Bear in mind the information on cleaning and maintenance.
5. Lubricate the vehicle according to the lubrication plan.
6. Allow the vehicle to dry and check it again for salt deposits.

## **Loose threaded fittings and attachments**

Contact a Wacker Neuson service center.



### 7.6 Lubrication work

– see chapter “Preparing lubrication” on page 7-7

### 7.7 Fuel system

#### Important information regarding the fuel system



##### **Information**

In order to prevent the formation of condensation water, fill up the fuel tank nearly completely at the end of each working day.



##### **Information**

Do not run the fuel tank completely dry. Otherwise, air is drawn into the fuel system. This requires bleeding the fuel system.

#### Diesel fuel specification

##### **NOTICE**

Engine damage due to incorrect or dirty diesel fuel.

- ▶ Only use clean diesel fuel according to the **fluids and lubricants** list.
- ▶ Do not use any diesel fuel with additives.

– see “Fluids and lubricants” on page 7-13

## Refueling

---

 **WARNING****Explosion hazard due to flammable fuel/air mixtures!**

Fuels develop explosive and flammable mixtures with air that can cause serious burns or death.

- ▶ Fire, open flames and smoking is prohibited.
  - ▶ Open tank lock carefully to release the pressure in the fuel tank.
  - ▶ Keep the maintenance area clean.
  - ▶ Do not refuel in closed rooms.
  - ▶ Do not add gasoline to diesel fuel.
  - ▶ Let the engine cool down.
- 

 **CAUTION****Health hazard due to diesel fuel!**

Diesel fuel and fuel vapors are harmful to health.

- ▶ Avoid contact with the skin, eyes and mouth.
  - ▶ Seek medical attention immediately in case of accidents with diesel fuel.
  - ▶ Wear protective equipment.
- 

 **CAUTION****Fire hazard due to diesel fuel!**

Diesel fuel gives off flammable vapors. This can cause injury.

- ▶ Fire, open flames and smoking is prohibited.
  - ▶ Do not add gasoline to diesel fuel.
- 

 **CAUTION****Slipping/tripping hazard when refueling the vehicle!**

Can cause injury.

- ▶ Use safety-oriented ladders for refueling the vehicle.
  - ▶ Do not use vehicle parts or attachments as a climbing aid.
-

---

**NOTICE**

Do not refuel with cans in order to avoid dirt in the fuel.

---

**Refueling with a stationary fuel pump**

The fuel tank is located under the valve cover.

1. Stop the vehicle on firm, level, and horizontal ground.
  2. Position the boom straight ahead at the center of the vehicle.
  3. Lower the boom.
  4. Stop the engine
  5. Raise the control lever base.
  6. Open tank lock **C** carefully to release the pressure in the fuel tank.
  7. Refuel the vehicle.
  8. Close the tank lock **C**.
- 

**NOTICE**

Even the smallest particles of dirt can cause increased engine wear, malfunctions in the fuel system and reduced effectiveness of the fuel filters.

---

**Refueling from barrels**

- If refueling from barrels cannot be avoided, note the following points:
- Barrels must neither be rolled nor tilted before refueling.
- Protect the suction pipe opening of the barrel pump with a fine-mesh screen.
- Immerse the suction pipe opening down at least 15 cm (6 in) above the bottom of the barrel.
- Only fill the tank using refueling aids (funnels or filler pipes) with an integral microfilter.
- Keep all refueling containers clean.

## Fuel filter

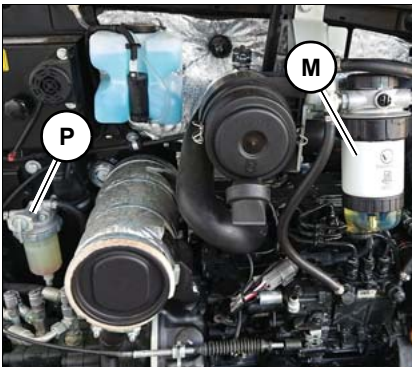

Fig. 204

The fuel prefilter **P** and fuel main filter **M** are located under the engine cover.

Both are equipped with a water separator.

## Empty the water separator (prefilter)

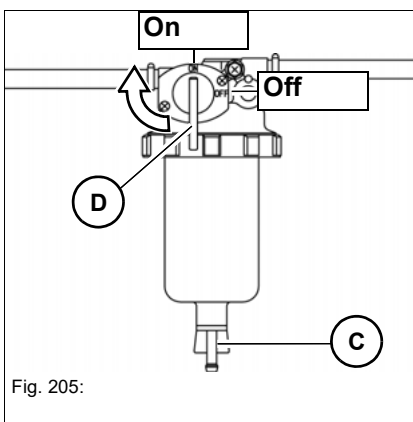

Fig. 205:

1. Stop and park the vehicle Stop the engine See "Preparing lubrication".
2. Open the engine cover.
3. Prepare a suitable container for collecting the fuel/water mixture.
4. Connect a drain hose to connection **C**. Place the hose into a container on the ground.
5. Turn ball valve **D** to the **OFF** mark.
  - ➔ Fuel supply is interrupted.
6. Unscrew connection **C**.
7. Collect the fuel/water mixture in a suitable container.
8. Screw connection **C** back on again.
9. Turn ball valve **D** to the **ON** mark.
  - ➔ Fuel supply is open.
10. Remove the hose.
11. Close and lock the engine cover.

## Empty the water separator (main filter)

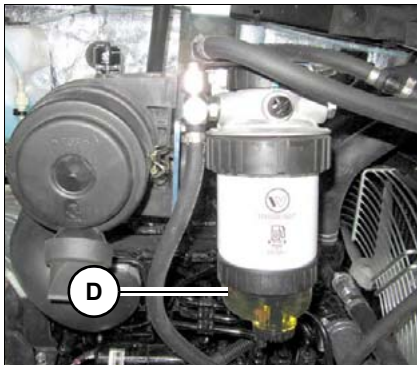

Fig. 206 (symbolic representation)

Empty the main filter if the fuel/water mixture rises to position **D**.

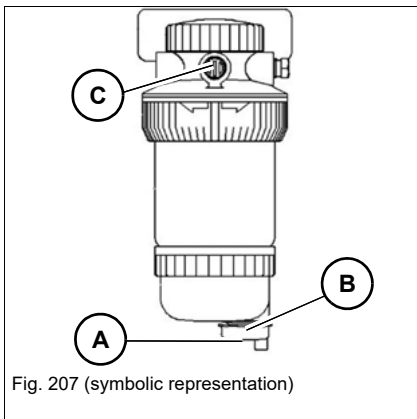

Fig. 207 (symbolic representation)

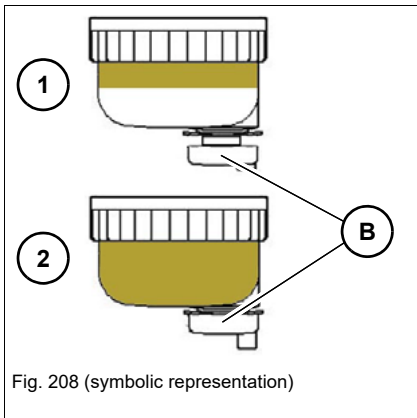

Fig. 208 (symbolic representation)

1. Stop and park the vehicle Stop the engine See “**Preparing lubrication**”.
2. Prepare a suitable container for collecting the fuel/water mixture.
3. Open the engine cover.
4. Connect a suitable hose to the drain device **A**.
5. Open drain valve **B**.
6. Loosen bleed screw **C**.
7. Drain the fuel/water mixture into a receptacle (1).
8. Tighten bleed screw **C**.
9. Close drain valve **B** if nothing but fuel is visible in the sight glass (2).
10. Remove the hose.
11. Close and lock the engine cover.



### Environment

Use a suitable container to collect fluids and lubricants as they flow out and dispose of them in an environmentally friendly manner.

## Bleeding the fuel system

Bleed the fuel system in the following cases:

- After removing and fitting the fuel filter, prefilter or the fuel lines back on again.
- If the vehicle is put into operation after having been out of operation for more than 30 days.

### **Bleed:**

1. Raise the control lever base.
2. Remove the starting key and carry it with you.
3. Fill up and close the fuel tank.
4. Turn the starting key to the first position.
5. Wait about 5 minutes while the fuel system bleeds itself automatically.
6. Start the engine.

If the engine runs smoothly for a while and then stops, or if it does not run smoothly:

1. Stop the engine
2. Raise the control lever base.
3. Remove the starting key and carry it with you.
4. Bleed the fuel system again as described above.
5. Check for leaks after starting the engine.
6. Have a Wacker Neuson service center perform a check if necessary.

### 7.8 Engine lubrication system

#### Important information regarding the engine lubrication system

---

##### **NOTICE**

Possible engine damage due to incorrect engine oil level.

- ▶ The oil level must be between the MIN and MAX marks.
- 

##### **NOTICE**

Damage due to wrong engine oil.

- ▶ Use engine oil according to **Fluids and lubricants** list.
  - ▶ Have the oil changed only by a Wacker Neuson service center.
- 

##### **NOTICE**

Possible engine damage due to adding engine oil too quickly.

- ▶ Add the engine oil slowly so it can go down without entering the intake system.
- 



##### **Information**

Check the oil level once a day. Wacker Neuson recommends checking before starting the engine. Check the oil level not less than five minutes after stopping the engine.

---



## Checking the engine oil level

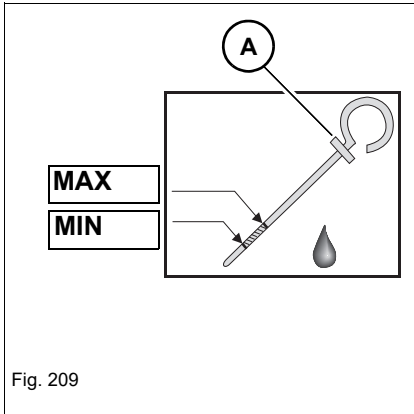

Fig. 209

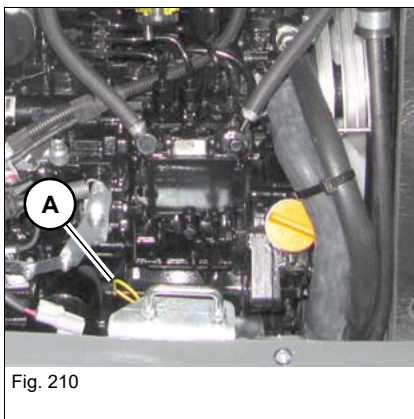

Fig. 210

1. Stop and park the vehicle Stop the engine See "Preparing lubrication".
2. Open the engine cover.
3. Wipe the area around oil dipstick **A** with a lint-free cloth.

4. Pull out oil dipstick **A** and wipe it with a lint-free cloth.
5. Slide in oil dipstick **A** completely.
6. Withdraw it and read off the oil level.
  - The oil level must be between the MIN and MAX marks.
  - Add engine oil if necessary.
7. Slide in oil dipstick **A** completely.
8. Close and lock the engine cover.

## Adding engine oil

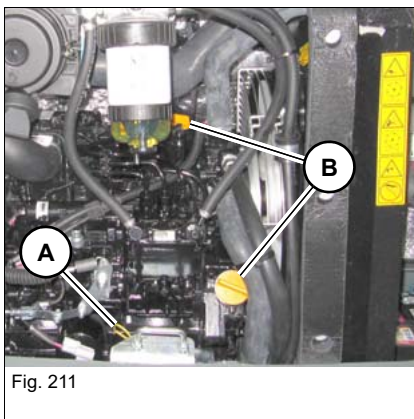

Fig. 211

1. Stop and park the vehicle Stop the engine See "Preparing lubrication".
2. Open the engine cover.
3. Wipe the area around the sealing push-in cap with a lint-free cloth.
4. Open filler cap **B**.
5. Raise oil dipstick **A** slightly to allow any trapped air to escape.
6. Add engine oil.
7. Wait at least five minutes until all the oil has run into the oil sump.
8. Check the oil level.
9. Add oil if necessary and check the oil level again.
10. Close filler cap **B**.
11. Slide in oil dipstick **A** completely.
12. Close and lock the engine cover.



### Environment

Use a suitable container to collect fluids and lubricants as they flow out and dispose of them in an environmentally friendly manner.

## 7.9 Cooling system

### Important information regarding the cooling system

The radiators are located on the right in the engine compartment.

---

 **WARNING**

**Poisoning hazard due to hazardous substances!**

Contact with hazardous substances can cause serious injury or death.

- ▶ Wear protective equipment.
  - ▶ Do not inhale or swallow coolant.
  - ▶ Avoid contact of the coolant or antifreeze with the skin and eyes.
- 

 **WARNING**

**Burn hazard due to coolant or antifreeze!**

The coolant and antifreeze are easily flammable fluids that can cause serious burns or death if they are brought into contact with fire or open flames.

- ▶ Wear protective equipment.
  - ▶ Only perform maintenance on an engine that has cooled down.
  - ▶ Fire, open flames and smoking is prohibited.
- 

 **WARNING**

**Burn hazard due to hot coolant!**

At high temperatures, the cooling system is under pressure and can cause burning of the skin.

- ▶ Wear protective equipment.
  - ▶ Let the engine cool down.
  - ▶ Carefully open the radiator cap.
- 

**NOTICE**

Possible engine damage due to wrong coolant.

- ▶ Observe the engine/vehicle fluid table or coolant compound table.
-

---

**NOTICE**

Possible engine damage due to low coolant level.

- ▶ Check the coolant level once a day.
- 

**i** **Information**

Check the coolant level once a day before starting the engine.  
Observe the coolant compound table.

---

**Check and top off the coolant**

Fig. 212

1. Preparations – see chapter “Parking the vehicle” on page 5-9
  2. Carefully unscrew the filler cap **A** and release the pressure.
  3. Check the coolant in the radiator **B**.
  4. Top off the coolant until the coolant reaches the filler inlet of the radiator **B**.
  5. Tighten filler cap **A**.
  6. Check the coolant level in the expansion tank **C**.
  7. Top off the coolant until the coolant reaches the mark **FULL** in the expansion tank **C**.
  8. Start the engine and let it warm up for about 5 – 10 minutes.
  9. Stop the engine
  10. Remove the starting key and carry it with you.
  11. Let the engine cool down.
  12. Check the coolant level again.
  13. If necessary, add coolant and repeat the procedure until the coolant level remains constant.
  14. Close and lock the engine cover.
- 

**i** **Information**

Check the coolant level once a day before starting the engine.  
Observe the coolant compound table.

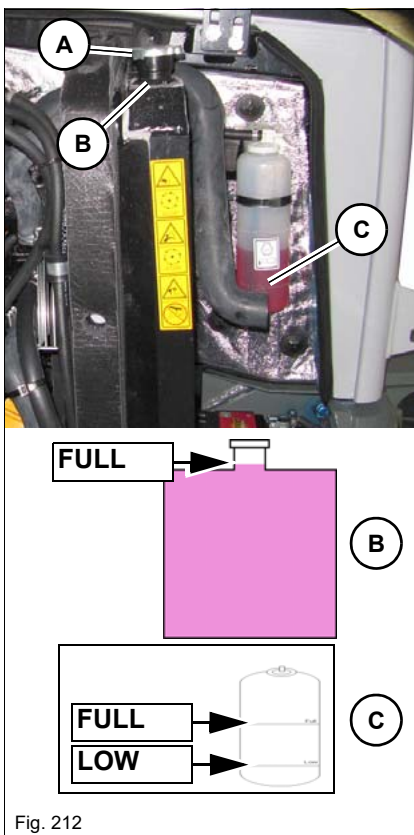
---

## Cleaning the radiator

---

### CAUTION

#### Burn hazard due to hot surfaces!

Hot radiators can cause burns.

- ▶ Stop the engine and let it cool down.
  - ▶ Wear protective equipment.
- 

### NOTICE

Possible engine damage or damage to the hydraulic system from dirty radiator fins.

- ▶ Check and if necessary clean the radiator once a day.
  - ▶ In dusty or dirty work conditions, clean more frequently than indicated in the maintenance plans.
- 

### NOTICE

Possible damage to radiator fins during cleaning.

- ▶ Keep a safe distance from the radiator.
  - ▶ Only use oil-free compressed air 2 bar (29 psi max.).
- 

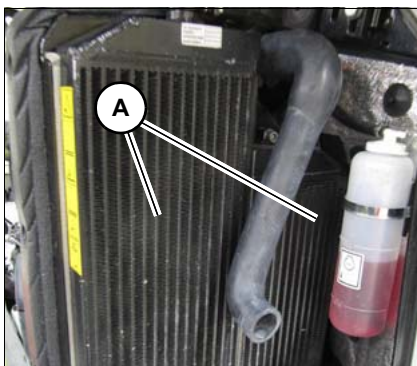

Fig. 213

Radiators **A** are located on the right in the engine compartment.

1. Stop and park the vehicle Stop the engine See "Preparing lubrication".
2. Open the engine cover.
3. Remove dust and other foreign bodies from the fins with compressed air.
4. Close and lock the engine cover.

## 7.10 Air filter

Have maintenance performed only by a Wacker Neuson service center.

### **NOTICE**

Possible engine damage due to intake of dirty air.

- ▶ Check the dirt indicator and air intake daily before commissioning.

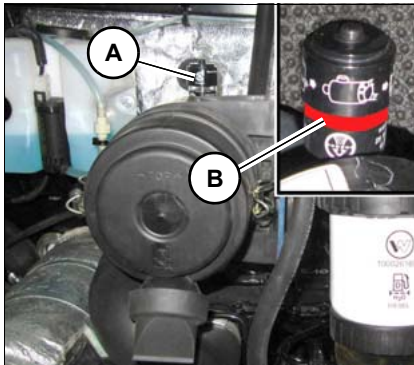

Fig. 214

With the contamination display **A**, if the red ring **B** appears, contact an authorized service center.

### Checking the air intake

### **NOTICE**

Possible engine damage due to intake of dirty air.

- ▶ Check once a day before putting the vehicle into operation.

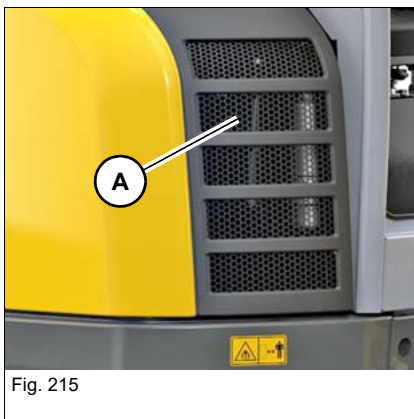

Fig. 215

1. Stop and park the vehicle Stop the engine See "Preparing lubrication".
2. Remove the starting key and carry it with you.
3. Check and if necessary clean ventilation grill **A**.

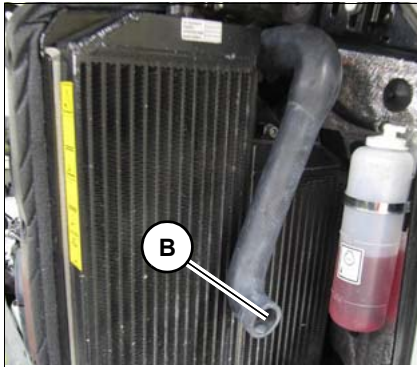

Fig. 216

4. Open the engine cover.
5. Check the air intake **B** and clean it if necessary.

### 7.11 V-belt

V-belt tension may be checked and the V-belt re-tensioned only by a Wacker Neuson service center.

## 7.12 Hydraulic system

### Important information on the hydraulic system

---

 **WARNING****Burn hazard due to hot hydraulic oil!**

Hot hydraulic oil can cause burning to the skin, serious injury or death.

- ▶ Release the pressure in the hydraulic system.
  - ▶ Let the engine cool down.
  - ▶ Wear protective equipment.
- 

 **WARNING****Injury hazard due to fluid escaping under pressure!**

Hydraulic oil escaping under pressure can penetrate the skin and cause serious injury or death.

- ▶ Do not operate the vehicle with leaking or damaged hydraulic system components.
  - ▶ Open the breather filter carefully to slowly release the pressure inside the reservoir.
  - ▶ Wear protective equipment. If hydraulic oil contacts the eye flush immediately with clean water and seek medical treatment.
  - ▶ Malfunctioning or leaking screw connections, hose connections and pressure lines must be immediately repaired by a Wacker Neuson service center. Search for hydraulic leaks with a piece of cardboard.
  - ▶ Always consult a doctor immediately, even if the wound seems insignificant. Hydraulic oil causes blood poisoning.
-

---

### **NOTICE**

Damage due to wrong hydraulic oil.

- ▶ Only use hydraulic oil according to the **fluids and lubricants** list.
  - ▶ Have the hydraulic oil only changed by an authorized service center.
- 

---

### **NOTICE**

Damage to hydraulic system due to incorrect hydraulic oil level.

- ▶ With a warm engine, the hydraulic oil must be about at the middle of the sight glass.
  - ▶ Check the hydraulic oil level once a day.
- 

---

### **NOTICE**

Possible damage to hydraulic system due to dirty hydraulic oil.

- ▶ Always add hydraulic oil using the filling screen.
  - ▶ If the hydraulic oil in the sight glass is cloudy, this indicates that water or air has penetrated the hydraulic system. Contact a Wacker Neuson service center.
  - ▶ Contact an authorized service center if the filter of the hydraulic system is dirty.
-



## Checking the hydraulic oil level

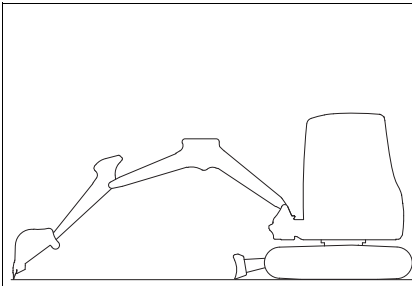

Fig. 217 (symbolic representation)

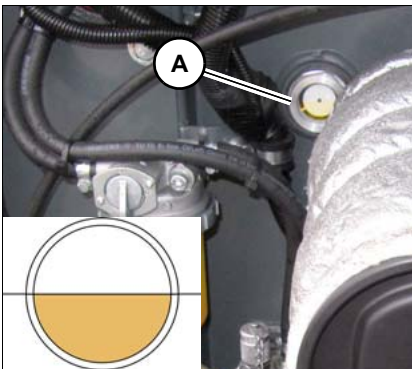

Fig. 218

1. Park the vehicle on firm, level, and horizontal ground.
2. Position the boom straight ahead at the center of the vehicle (see figure).
3. Lower the boom and the stabilizer blade to the ground.
4. Stop the engine
5. Operate the control lever repeatedly to release the pressure in the hydraulic system.
6. Remove the starting key and carry it with you.
7. Sight glass **A** is located in the engine compartment.
8. Check the oil level on sight glass **A**.
  - ➔ If the engine is warm, the oil level must be approximately at the middle of sight glass **A**.
9. Add hydraulic oil if the oil level is below this mark.

## Adding hydraulic oil

### CAUTION

#### Slipping/tripping hazard when adding hydraulic oil!

Can cause injury.

- ▶ Use a safety-oriented ladder to add hydraulic oil.
- ▶ Do not use vehicle parts or attachments as a climbing aid.

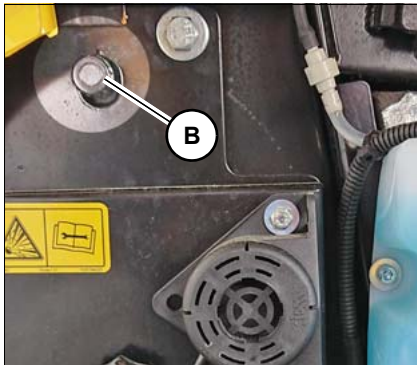

Fig. 219

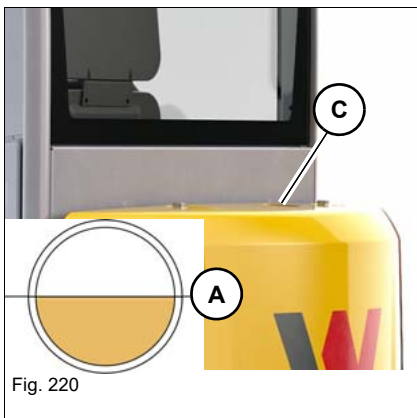

Fig. 220

1. Open the engine cover.
2. Open the reservoir ventilation **B** to release the pressure inside the hydraulic oil reservoir.

3. Slowly open cover **C**.
4. Add hydraulic oil up to the corresponding mark.
5. Check the hydraulic oil level on sight glass **A**.
6. Add if necessary and check again.
7. Screw on cover **C** and tank ventilation **B**.
8. Close and lock the engine cover.



### Environment

Use a suitable container to collect fluids and lubricants as they flow out and dispose of them in an environmentally friendly manner.

## Checking the hydraulic system and hoses

Check the hydraulic system and hydraulic lines daily for leaks and general condition.

### **NOTICE**

Damage to the hydraulic system due to leaks and damaged hydraulic lines.

- ▶ Leaks and damaged hydraulic lines must be immediately repaired at an authorized service center. This increases the operating safety of the vehicle and contributes to environmental protection.
- ▶ Do not operate the vehicle with leaking or damaged hydraulic lines.

Hydraulic hoses are subject to natural aging. Therefore, they must be checked regularly, even when there is no visible damage, which prevents safe operation.

Wacker Neuson recommends following schedule for checks:

Normal wear	12 months
Increased wear (longer operation duration, multi-shift operation, high outside temperatures, aggressive environmental conditions etc.)	6 months

### **Responsibility of checking hydraulic hose**

The vehicle operator must decide the intervals at which the hydraulic hose has to be checked and the decision will be based on the actual work situation.

To do this, the vehicle operator must appoint a qualified person, who will check the hydraulic hoses. If there is noticeable damage, the hydraulic hose must be replaced immediately. Do not start the vehicle. The findings from this check must be retained in writing by the vehicle operator till the next scheduled check.

### 7.13 Electrical system

#### Important information regarding the electrical system

Maintenance and repair work on the electrical system may be performed only by a Wacker Neuson service center!

- Malfunctioning parts of the electrical system must be replaced by an authorized service center.
- Light bulbs and fuses may be replaced by the operator.

#### Alternator

- Contact a Wacker Neuson service center if the alternator charge indicator light is malfunctioning.



#### **WARNING**

##### **Injury hazard due to malfunctioning batteries!**

Batteries give off explosive gases that can cause deflagrations if ignited.

- ▶ Wear protective equipment.
  - ▶ Fire, open flames and smoking is prohibited.
  - ▶ Do not jump start the engine if the battery is malfunctioning or frozen, or if the acid level is too low.
  - ▶ Do not place conductive articles on the battery – risk of short circuit.
- 

#### **NOTICE**

Possible damage to electrical components or engine electronics.

- ▶ Do not place conductive articles on the battery – risk of short circuit.
  - ▶ Do not interrupt voltage-carrying circuits at the battery terminals because of the sparking hazard.
  - ▶ Do not disconnect the battery while the engine is running.
- 



#### **Environment**

Dispose of old batteries in an environmentally friendly manner.

---

## Fuses and relays

– see chapter “9.8 Electrical system” on page 9-3

## Battery

The battery may be checked, disconnected, charged and replaced only by a Wacker Neuson service center.

## 7.14 Heating, ventilation and air conditioning system

### Checking/changing the cabin air filter

Have maintenance performed only by a Wacker Neuson service center.

## 7.15 Washer system

Only use glass cleaner and antifreeze for refilling.

### Checking the fluid level and adding fluid



#### **CAUTION**

#### **Burn hazard due to hot surfaces!**

Can cause serious burns or death.

- ▶ Stop the engine and let it cool down.
- ▶ Wear protective equipment.

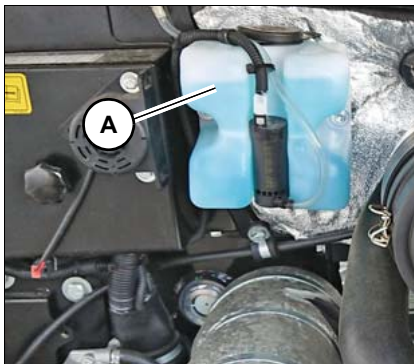

Fig. 221

The container **A** is located on the left in the engine compartment.

1. Stop and park the vehicle Stop the engine See “**Preparing lubrication**”.
2. Open the engine cover.
3. Check the fluid level in container **A** and add fluid if necessary.
4. Close and lock the engine cover.

## 7.16 Travel drive

Have maintenance performed only by a Wacker Neuson service center.

## 7.17 Braking system

Have maintenance performed only by a Wacker Neuson service center.

## 7.18 Tracks

### WARNING

**Crushing hazard during work under the vehicle!**

Working under the tracks can cause serious injury or death.

► Do not allow anyone to stay in the danger zone.

### Checking track tension

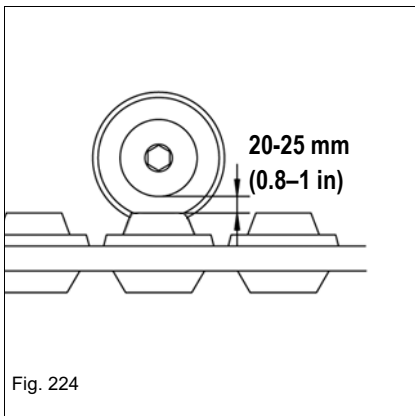
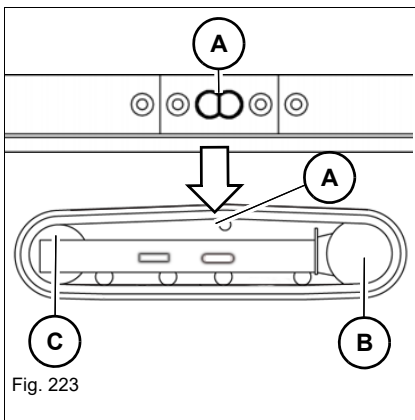
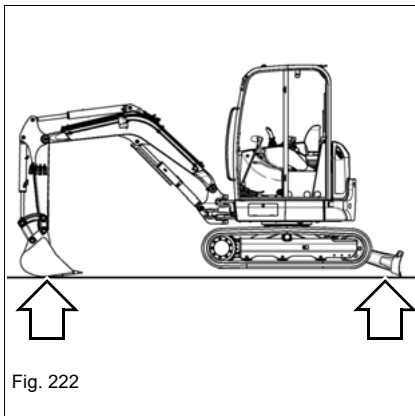

### Rubber tracks

1. Park the vehicle on firm, level, and horizontal ground.
2. Raise the vehicle evenly and horizontally by means of the boom and stabilizer blade.
3. Place the tracks so that mark **A** is in the middle between drive pinion **B** and track tension roller **C**.
4. Stop the engine
5. Operate the control lever repeatedly to release the pressure in the hydraulic system.
6. Raise the control lever base.
7. Remove the starting key and carry it with you.
8. Adjust the track tension if the play between the track roller and the track is not 20 – 25 mm (0.8 – 1 in).

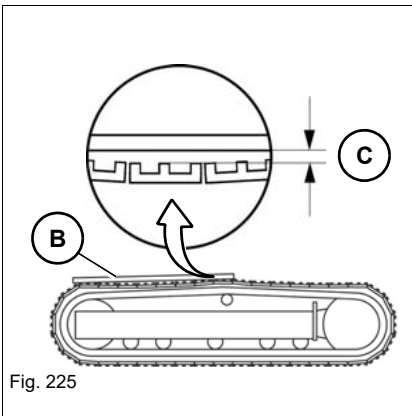

Fig. 225

### Correcting track tension

#### Steel track

Place a measuring rod **B** across the highest points of the track.

- ▶ Adjust the track tension if play **C** between the track roller and the track is not 20 - 25 mm (0.8 - 1 in).

---

#### **WARNING**

##### **Injury hazard due to grease escaping under pressure!**

Grease escaping under pressure can penetrate the skin and cause serious injury or death.

- ▶ Open the lubricating valve only very carefully and do not unscrew it more than one revolution.
- ▶ Wear protective equipment.
- ▶ Contact a Wacker Neuson service center if you are unable to reduce the track tension.

---

#### **NOTICE**

Possible damage to cylinders and tracks due to over-tightening.

- ▶ Tighten the tracks only up to the mandatory measuring distance.
-

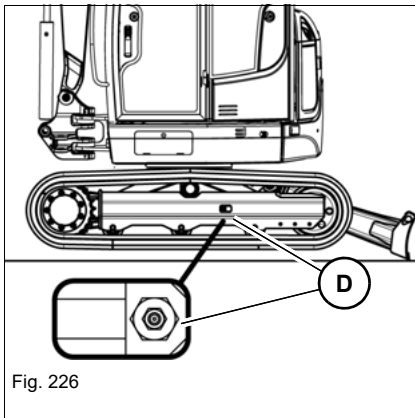

Fig. 226

### Tightening the tracks

1. Park the vehicle on firm, level, and horizontal ground.
2. Raise the vehicle evenly and horizontally by means of the boom and stabilizer blade.
3. Stop the engine
4. Operate the control lever repeatedly to release the pressure in the hydraulic system.
5. Pump grease with a grease gun through lubricating valve **D**.
6. Start the engine.
7. Lower the vehicle to the ground.
8. In order to check that the tension is correct:
  - Let it run at idling speed without any load
  - Slowly move the vehicle forward and reverse and switch it off again.
9. Check the track tension again.
  - If it is not correct:
10. Repeat steps 2–9. Contact a Wacker Neuson service center if track tension still is too low after pumping in more grease.

### Reducing tension

1. Place a suitable container underneath to collect the grease.
2. Slowly turn lubricating valve **D** a maximum of one revolution anticlockwise to release the grease.
  - The grease flows out of the groove of the lubricating valve.
3. Re-tighten lubricating valve **D**.
4. In order to check that the tension is correct:
  - Lower the vehicle to the ground,
  - Start the engine,
  - Let it run at idling speed without any load, then slowly move the vehicle forward and reverse, then turn it off again. Raise the vehicle again by means of the boom and stabilizer blade.
5. Check the track tension again.
  - If it is not correct:
6. Adjust again.

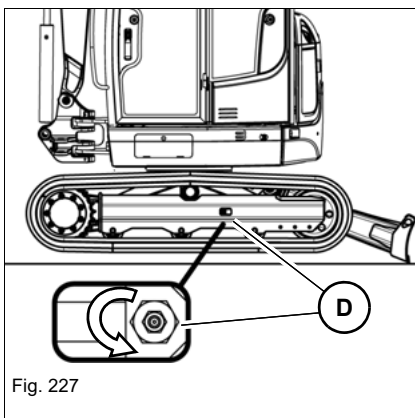

Fig. 227



### Environment

Use a suitable container to collect fluids and lubricants as they flow out and dispose of them in an environmentally friendly manner.



## **7.19 Maintenance of attachments**

### **Important information regarding maintenance of attachments**

Correct maintenance and service is absolutely necessary for smooth and continuous operation, and for an increased service life of the attachments. Please observe the lubrication and maintenance instructions in the Operator's Manuals of the attachments.

## **7.20 Maintenance of options**

Have a Wacker Neuson service center check all eyes regularly:

- Machine lifting eyes
- Attachment lifting eyes
- Attachment load hooks
- Tie-down points
- Towing eyes

Have eyes or load hooks with inadmissible wear, a defective spring mechanism, etc. immediately replaced by a Wacker Neuson service center.



### 7.21 Exhaust gas treatment

Not available

### 7.22 Machine preservation

Each vehicle gets a partly preservation at the factory (for example in the engine compartment). Operation in an aggressive environment (for example salt deposits) is prohibited.

## 8 Troubleshooting

### NOTICE

Contact a Wacker Neuson service center in case of malfunctions or signs that are not listed in the following tables or that persist after maintenance has been performed correctly.

### 8.1 Diesel engine malfunctions

Malfunction/sign	Possible cause	Remedy	See
Engine does not start or is not easy to start	Empty fuel tank	Refueling	<a href="#">7-23</a>
	Malfunctioning or empty battery	Contact a Wacker Neuson service center	--
	Malfunctioning fuse	Check the fuse	<a href="#">9-4</a>
Engine starts, but does not run smoothly or faultless	Air in fuel system	Bleeding the fuel system	<a href="#">7-27</a>
Engine overheats	Engine oil level too low	Adding engine oil	<a href="#">7-29</a>
	Dirty air filter	Contact a Wacker Neuson service center	--
	Dirty radiator fins	Cleaning the radiator	<a href="#">7-32</a>
	Coolant level too low	Adding coolant	<a href="#">7-31</a>
Engine does not have enough output	Dirty air filter	Contact a Wacker Neuson service center	--
Insufficient or no engine oil pressure	Engine oil level too low	Adding engine oil	<a href="#">7-27</a>
Black engine smoke	Dirty air filter	Contact a Wacker Neuson service center	--

### 8.2 Malfunctions

Malfunction/sign	Possible cause	Remedy	See
Machine does not stay on track, machine pulls to the right or left	Wrong track tension	Tighten tracks correctly	<a href="#">7-42</a>
	Foreign bodies stuck in track	Remove foreign bodies	--
	Uneven wear of tracks	Contact a service center	--

### 8.3 Malfunctions of the hydraulic system

Malfunction/sign	Possible cause	Remedy	See
Upper carriage is difficult to rotate, or does not rotate at all	Insufficient lubrication	Lubrication	<a href="#">7-27</a>
Machine does not work, or with reduced output	Hydraulic oil level too low	Adding hydraulic oil	<a href="#">7-27</a>
The display element emits a continuous acoustic warning	Malfunctioning pressure switch of safe load indicator	Stop the engine Contact a Wacker Neuson service center.	--

### 8.4 Malfunctions of attachments

#### Power tilt unit

Malfunction/sign	Possible cause	Remedy	See
Power tilt does not maintain its position	Internal release valve activated	Repeat the work operation with less load. Contact a Wacker Neuson service center if this problem persists	--
Lateral movement of the bucket	A little play due to necessary spacing between teeth is normal	--	--

## 9 Technical data

### 9.1 Models and trade names

– see chapter “Model designations and trade names” on page 3-2

### 9.2 Engine

Engine		
Manufacturer	Yanmar	
Type	3TNV76	3TNV80F
Design	Water-cooled 3-cylinder diesel engine	
fuel injection system	Indirect	
Displacement	1116 cm <sup>3</sup> (68.1 in <sup>3</sup> )	1266 cm <sup>3</sup> (77.3 in <sup>3</sup> )
power	15.7 kW at 2500 rpm (21 hp at 2500 rpm)	15.2 kW at 2500 rpm (20.4 hp at 2500 rpm)
Max. torque	66.1 Nm at 1800 rpm (48.8 ft.lbs. at 1800 rpm)	66.5 Nm at 1800 rpm (49 ft.lbs. at 1800 rpm)
Max. engine speed without load	2675 +/- 25 rpm	2700 +/- 25 rpm
Idling speed	1300 +/- 25 rpm	
Preheating system	Glow plugs	
Exhaust values according to:	China III	EPA tier IV final



#### Information

Over 800 m (2625 ft), the vehicle (3TNV80F) has a slightly lower hydraulic performance.

### 9.3 Traveling drive

Travel drive	
Version	Axial piston motor

### 9.4 Brake

See "Drive levers/accelerator pedals"

### 9.5 Tracks

Rubber track	
Track width	300 mm (12 in)

### 9.6 Steering system

See "Drive levers/accelerator pedals"

### 9.7 Work hydraulics

Work hydraulics	
Max. operating pressure	225 ±5 bar (3263 ±72 psi)
Oil flow	90.2 l/min (23.8 gal/min)
Rotation speed of upper carriage	10.25 rpm

### Maximum speed

Maximum speed	
Speed range 1	2.1 km/h (1.3 mph)
Speed range 2	3.8 km/h (2.3 mph)

## 9.8 Electrical system

---

 **WARNING**

**Fire hazard in case of incorrect handling of electric components!**

Can cause serious injury or death.

- ▶ Use only specified fuses.
  - ▶ Do not repair or bypass fuses.
  - ▶ If a replaced fuse is blown again directly, do not put the vehicle into operation and contact a Wacker Neuson service center.
- 

**NOTICE**

Explosion hazard in case of incorrect handling of fuses.

- ▶ Use only specified fuses.
  - ▶ Do not repair or bypass fuses.
  - ▶ If a replaced fuse is blown again directly, do not put the vehicle into operation and contact a Wacker Neuson service center.
- 

### Electrical components

Electrical components	
Alternator	12 V/40 A
Starter	12 V/1.1 kW (1.5 hp)
Battery	12 V/44 Ah

### Fuses/relays

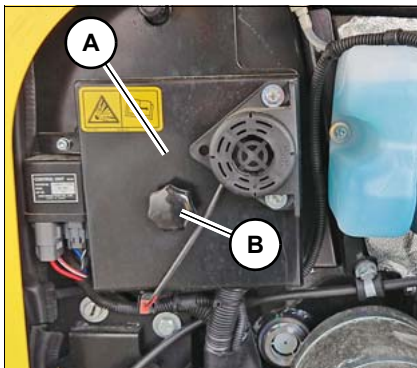

Fig. 228

The fuse box **A** is located on the left of the engine compartment.

**1. Opening:**

1. Stop and park the vehicle Stop the engine  
- See "Preparing lubrication".
2. Open the engine cover.
3. Loosen screw **B** and remove the cover.

**Closing:**

1. Install the cover and tighten screw **B**.

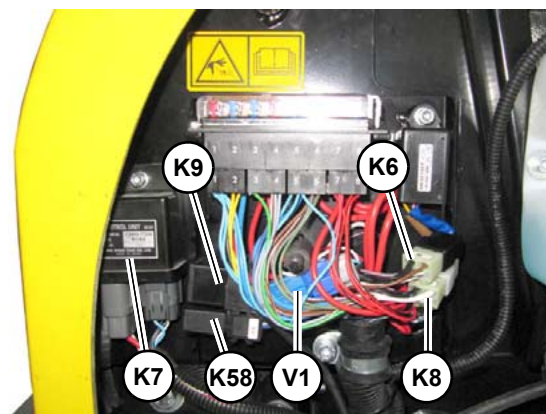
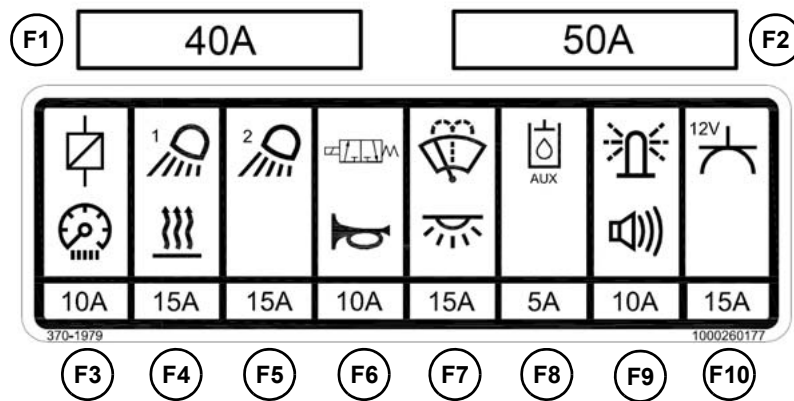

Fig. 229



**Assignment**

<b>Fuses</b>	
F1	Start, preheat, cutoff solenoid
F2	Starter, air-pressure sensor/output adaptation (Yanmar 3TNV80F-SNNS)
F3	Display, cutoff solenoid, relays, overload pressure switch
F4	Boom working light, heating
F5	Cabin roof lights
F6	Valves, horn, travel signal
F7	Wiper, interior light
F8	Proportional auxiliary hydraulics (AUX I) Proportional 3rd control circuit (AUX II)
F9	Rotating beacon, radio
F10	Socket, 12 V power outlet

**Relays**

<b>Relays</b>	
V1	Blocking diode
K6	Preheating time lag relay (blue)
K7	Starting relay
K8	Preheating time lag relay (brown)
K9	Cutoff solenoid
K58	Speed range 2

## Illuminants

<b>Bulbs</b>		
Working lights	LED lamp	-- <sup>1</sup>
Rotating beacon	LED lamp	-- <sup>1</sup>

1. LED lamps can not be changed.

## Powertilt

<b>Powertilt</b>	
Swiveling range	approx. 180° <sup>1</sup>

1. The actual angle can vary slightly from the indication made here.

## 9.9 Tightening torques

### General tightening torques

Property class	8.8	10.9	12.9	8.8	10.9
Screw dimensions	Screws according to DIN 912, DIN 931, DIN 933, etc.			Screws according to DIN 7984	
	Nm (ft.lbs.)	Nm (ft.lbs.)	Nm (ft.lbs.)	Nm (ft.lbs.)	Nm (ft.lbs.)
M5	5.5 (4)	8 (6)	10 (7)	5 (4)	7 (5)
M6	10 (7)	14 (10)	17 (13)	8.5 (6)	12 (9)
M8	25 (18)	35 (26)	42 (31)	20 (15)	30 (22)
M10	45 (33)	65 (48)	80 (59)	40 (30)	59 (44)
M12	87 (64)	110 (81)	147 (108)	69 (51)	100 (74)
M14	135 (100)	180 (133)	230 (170)	110 (81)	160 (118)
M16	210 (155)	275 (203)	350 (258)	170 (125)	250 (184)
M18	280 (207)	410 (302)	480 (354)	245 (181)	345 (254)
M20	410 (302)	570 (420)	690 (509)	340 (251)	490 (361)
M22	550 (406)	780 (575)	930 (686)	460 (339)	660 (487)
M24	710 (524)	1000 (738)	1190 (878)	590 (435)	840 (620)
M27	1040 (767)	1480 (1092)	1770 (1305)	870 (642)	1250 (922)
M30	1420 (1047)	2010 (1482)	2400 (1770)	1200 (885)	1700 (1254)

Tightening torques/fine-pitch thread					
Property class	8.8	10.9	12.9	8.8	10.9
Screw dimensions	Screws according to DIN 912, DIN 931, DIN 933, etc.			Screws according to DIN 7984	
	Nm (ft.lbs.)	Nm (ft.lbs.)	Nm (ft.lbs.)	Nm (ft.lbs.)	Nm (ft.lbs.)
M8X1.0	25 (18)	37 (28)	43 (32)	22 (16)	32 (24)
M10X1.0	50 (37)	75 (55)	88 (65)	43 (32)	65 (48)
M10X1.25	49 (36)	71 (52)	83 (61)	42 (31)	62 (46)
M12X1.25	87 (64)	130 (96)	150 (111)	75 (55)	110 (81)
M12X1.5	83 (61)	125 (92)	145 (107)	72 (53)	105 (77)
M14X1.5	135 (100)	200 (148)	235 (173)	120 (89)	175 (129)
M16X1.5	210 (155)	310 (229)	360 (266)	180 (133)	265 (195)
M18X1.5	315 (232)	450 (332)	530 (391)	270 (199)	385 (284)
M20X1.5	440 (325)	630 (465)	730 (538)	375 (277)	530 (391)
M22X1.5	590 (435)	840 (620)	980 (723)	500 (369)	710 (524)
M24X2.0	740 (546)	1070 (789)	1250 (922)	630 (465)	900 (664)
M27X2.0	1100 (811)	1550 (1143)	1800 (1328)	920 (679)	1300 (959)
M30X2.0	1500 (1106)	2150 (1586)	2500 (1844)	1300 (959)	1850 (1364)

## 9.10 Coolant Compound table

Outside temperature <sup>1</sup>	Distilled water	Coolant <sup>2</sup>
Up to °C (°F)	% by volume	% by volume
-37 (-34.6)	50	50

1. Use the 1:1 concentration for warm outside temperatures, too, to ensure protection against corrosion, cavitation, and deposits.
2. Do not mix the coolant with other coolants.

## 9.11 Noise emissions

Noise emissions	
Measured sound power level LwA <sup>1</sup>	93 dB (A)
Guaranteed sound power level LwA <sup>1</sup>	93 dB (A)

1. According to ISO 6395 (EC Directives 2000/14/EC and 2005/88/EC)



### Information

Measurements performed on asphalted surface.

## 9.12 Vibrations

Vibration <sup>1</sup>	
Effective acceleration value for the upper extremities of the body (hand-arm vibration)	< Trigger value < 2.5 m/s <sup>2</sup>
Effective acceleration value for the body (whole-body vibration)	< 0.5 m/s <sup>2</sup>

1. Uncertainty of measurement as per DIN EN 474-1:2014-03

## 9.13 Weights

Base vehicle	Transport weight <sup>1</sup> kg (lbs)	Operating weight <sup>2</sup> kg (lbs)
EZ25 (canopy)	2760 (6,085)	2860 (6,305)

1. Transport weight: basic vehicle (one-piece boom, short stick, rubber tracks) + 10 % fuel tank capacity
2. Operating weight: basic machine + full fuel tank + bucket (400 mm/16 in) + operator (75 kg/165 lbs)



### Information

Weight indications can vary by +/- 2%.

## Determining the loading weight

The basis for calculating the loading weight is the shipping weight indicated on the vehicle nameplate. Add subsequently installed options and attachments (e.g. bucket, Easy Lock, breaker console) to the shipping weight. Add fuel depending on the tank capacity.

Option <sup>1</sup>	kg (lbs)
VDS	279 (616)
Extra weight	120 (251)
Cab	86 (190)
Front Guard	35 (77)
Safe load indicator	25 (53)
3rd control circuit with proportional controls	18 (40)
Powertilt preparation	17 (37)
Grab control circuit	12 (26)
Quickhitch-ready	11 (24)
Long stick	10 (22)
Full fuel tank	30 (66)

1. The weight indications for options exclusively refer to Wacker Neuson original accessories.



### Information

The given weights are exemplary. In order to determine the actual weight, the vehicle must be weighed before transportation.

### Weight of attachments

– see chapter “*Technical data of attachments*” on page 9-11

### Fields of application and use of attachments

---



#### **WARNING**

##### **Accident hazard due to unauthorized attachments!**

If unauthorized attachments are used, the vehicle can tip over, which can lead to serious injury or death.

- ▶ Only use attachments released by Wacker Neuson.
- 

#### **NOTICE**

Machine can be damaged due to unreleased attachments.

- ▶ Only use the attachments specified in the table.
- 

Compare the weight of the attachment and its maximum payload with the indications in the relevant lift capacity table or load diagram. Never exceed the maximum payload stated in the lift capacity table or load diagram.

---



#### **Information**

Please refer to the Operator's Manual and maintenance manual of the attachment manufacturer for operating and maintenance instructions for attachments such as hammers, grabs, hydraulic quickhitches, etc.

---

## Technical data of attachments

The specified weights are exemplary and only serve as a guide. The actual weight may be lower or higher. In order to determine the actual weight, the attachment must be weighed.

Not all attachments are available for every vehicle.

There may be additional bucket widths that are not specified in this operator's manual.

Only use attachments released by Wacker Neuson. For more information, contact a Wacker Neuson sales partner.

Observe the national and regional regulations.

<b>Vehicle class 2-3 tons</b>		
<b>Bucket</b>	<b>Width mm (in)</b>	<b>Weight kg (lbs)</b>
Bucket	250 (10)	40-55 (90-125)
	300 (12)	45-60 (100-135)
	400 (16)	55-70 (125-155)
	500 (20)	60-80 (135-180)
	600 (24)	70-90 (155-200)
	700 (28)	75-100 (165-220)
Ditch cleaning bucket	850 (33)	65-75 (145-165)
	1000 (39)	75-105 (165-235)
	1200 (47)	85-120 (190-265)
	1400 (55)	130-145 (290-320)
Offset bucket	850 (33)	105-120 (235-265)
	1000 (39)	115-155 (255-345)
	1200 (47)	125-175 (280-390)

<b>Accessories of the vehicle class 2-3 tons</b>	<b>Weight kg (lbs)</b>
Consoles (Easy Lock, Lehnhoff system, etc.)	30-60 (70-135)
Hydraulic hammer	110-260 (245-575)
Powertilt (consoles, Easy Lock etc.)	70-150 (155-335)

## Excavator forces

According to ISO 6015

Max. tearout force (short stick)	15.3 kN (3440 lbf)
Max. tearout force (long stick)	13.6 kN (3057 lbf)
Max. breakout force at bucket tooth	22.5 kN (5058 lbf)

## Ground clearance/ground pressure

	without VDS	with VDS
Ground clearance	280 mm (11 in)	285 mm (11 in)
Ground pressure	> 0.27 kg/cm <sup>2</sup> (3.8 lbs/in <sup>2</sup> )	
Steel chain ground pressure	> 0.28 kg/cm <sup>2</sup> (4 lbs/in <sup>2</sup> )	

## 9.14 Lift capacity/load

### Safety instructions lift capacity tables

Observe the values of the lift capacity tables in normal operation (for example excavating).

Observe the values of the load diagrams in lifting gear applications.

#### **DANGER**

##### **Crushing hazard due to tipping over of vehicle!**

The vehicle causes serious injury or death when it tips over.

- ▶ The weight of the attachment and load must be subtracted from the weight specified in the corresponding column in the table.
- ▶ Pay attention to the density of the load.
- ▶ Do not exceed the weights indicated in the lift capacity tables.

#### **NOTICE**

If the weight is exceeded, there is a risk of damage to property if the vehicle tips over.

- ▶ Do not exceed the weights indicated in the load diagrams.

#### **Information**

The indications are only approximate values. Uneven ground or poor ground conditions affect vehicle stability. The operator must take these influences into account.



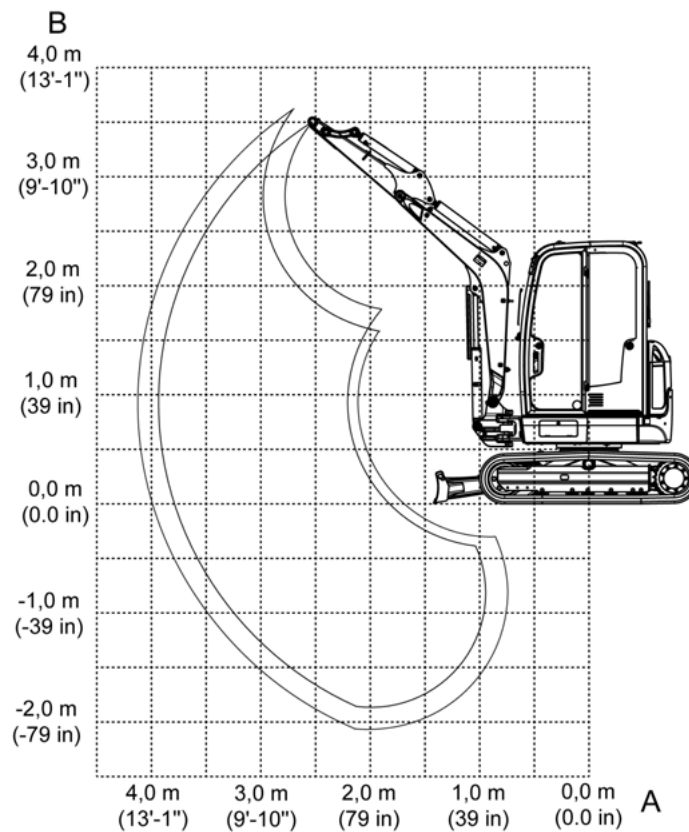

Designation	Explanation
A	Reach from live ring center
B	Load hook height
max	Authorized lift capacity with horizontal boom
I	Vehicle in travel direction, front dozer blade, dozer blade down, loss of dozer blade contact with ground
II	Vehicle 90° to travel direction, dozer blade up
III	Vehicle in travel direction, front dozer blade, dozer blade up, loss of front axle contact with ground

All table values are specified in kg (lbs), in horizontal position on firm and level ground without bucket or attachment (for example a hammer).

The vehicle's lift capacity is restricted by the settings of the pressure limiting valves, the hydraulic output and the hydraulic system's stabilizing features.

Neither 75% of the static tilt load nor 87% of the hydraulic lift capacity is exceeded.

Calculation basis according to ISO 10567

Setting pressure on boom cylinder: 22,500 kPa (3263 psi)

The lift capacity applies to vehicles under the following conditions:

- Lubricants and engine/vehicle fluids at the mandatory levels
- Full fuel tank
- Cabin or canopy
- Machine at operating temperature
- Operator weight 75 kg (165 lbs)

## Lift capacity tables

### 01 canopy, short stick

A \ B	2 m (79")			2.5 m (98")			3 m (9'-10")			3.5 m (11'-6")			max		
	I	II	III	I	II	III	I	II	III	I	II	III	I	II	III
3.0 m (9.8 ft)	-	-	-	-	-	-	505 (1113)	402 (886)	450 (992)	-	-	-	521 (1150)	365 (804)	408 (901)
2.0 m (6.6 ft)	-	-	-	603 (1329)	528 (1165)	597 (1317)	538 (1187)	390 (860)	438 (965)	505 (1113)	299 (660)	335 (739)	502 (1107)	261 (576)	293 (646)
1.0 m (3.3 ft)	-	-	-	895 (1973)	464 (1023)	530 (1168)	681 (1501)	356 (784)	402 (886)	569 (1255)	281 (620)	316 (698)	507 (1118)	231 (510)	260 (574)
0.0 m (0.0 ft)	1398 (3083)	608 (1342)	712 (1569)	992 (2188)	432 (952)	496 (1093)	750 (1654)	333 (733)	378 (833)	597 (1316)	267 (589)	302 (666)	517 (1141)	239 (526)	269 (593)
-1.0 m (-3.3 ft)	1105 (2437)	622 (1371)	726 (1600)	826 (1822)	436 (961)	500 (1103)	622 (1371)	335 (739)	381 (839)	-	-	-	512 (1128)	302 (666)	342 (753)

### 02 canopy, long stick

A \ B	2 m (79")			2.5 m (98")			3 m (9'-10")			3.5 m (11'-6")			max		
	I	II	III	I	II	III	I	II	III	I	II	III	I	II	III
3.0 m (9.8 ft)	-	-	-	-	-	-	434 (957)	407 (899)	434 (957)	-	-	-	470 (1035)	318 (701)	356 (786)
2.0 m (6.6 ft)	-	-	-	-	-	-	486 (1071)	393 (866)	441 (972)	462 (1019)	300 (661)	336 (741)	459 (1012)	236 (521)	265 (585)
1.0 m (3.3 ft)	-	-	-	832 (1835)	468 (1033)	535 (1179)	641 (1414)	356 (784)	402 (887)	541 (1192)	279 (615)	314 (693)	466 (1027)	210 (463)	237 (522)
0.0 m (0.0 ft)	1436 (3167)	599 (1321)	702 (1549)	985 (2172)	427 (941)	491 (1082)	739 (1630)	328 (723)	373 (823)	591 (1303)	262 (577)	297 (654)	478 (1054)	215 (475)	243 (537)
-1.0 m (-3.3 ft)	1199 (2645)	606 (1337)	710 (1566)	875 (1930)	425 (936)	488 (1077)	664 (1464)	324 (715)	370 (815)	-	-	-	482 (1062)	264 (582)	299 (659)

**03 canopy, short stick, additional weight**

A \ B	2 m (79")			2.5 m (98")			3 m (9'-10")			3.5 m (11'-6")			max		
	I	II	III	I	II	III	I	II	III	I	II	III	I	II	III
3.0 m (9.8 ft)	-	-	-	-	-	-	505 (1113)	457 (1008)	505 (1114)	-	-	-	521 (1150)	417 (919)	466 (1028)
2.0 m (6.6 ft)	-	-	-	603 (1329)	599 (1321)	603 (1330)	538 (1187)	445 (982)	499 (1101)	505 (1113)	345 (760)	385 (849)	502 (1107)	303 (668)	339 (747)
1.0 m (3.3 ft)	-	-	-	895 (1973)	535 (1179)	609 (1343)	681 (1501)	411 (906)	463 (1022)	569 (1255)	327 (720)	367 (808)	507 (1118)	271 (597)	303 (669)
0.0 m (0.0 ft)	1398 (3083)	706 (1556)	823 (1815)	992 (2188)	503 (1108)	575 (1268)	750 (1654)	388 (856)	439 (969)	597 (1316)	313 (690)	352 (777)	517 (1141)	280 (617)	314 (693)
-1.0 m (-3.3 ft)	1105 (2437)	719 (1585)	837 (1846)	826 (1822)	507 (1117)	579 (1277)	622 (1371)	391 (861)	442 (975)	-	-	-	512 (1128)	352 (776)	397 (875)

**04 canopy, long stick, additional weight**

A \ B	2 m (79")			2.5 m (98")			3 m (9'-10")			3.5 m (11'-6")			max		
	I	II	III	I	II	III	I	II	III	I	II	III	I	II	III
3.0 m (9.8 ft)	-	-	-	-	-	-	434 (957)	434 (957)	434 (957)	-	-	-	470 (1035)	365 (806)	408 (900)
2.0 m (6.6 ft)	-	-	-	-	-	-	486 (1071)	448 (988)	486 (1072)	462 (1019)	345 (761)	386 (851)	459 (1012)	275 (607)	308 (679)
1.0 m (3.3 ft)	-	-	-	832 (1835)	539 (1188)	614 (1354)	641 (1414)	411 (906)	464 (1022)	541 (1192)	325 (716)	365 (804)	466 (1027)	247 (545)	278 (612)
0.0 m (0.0 ft)	1436 (3167)	697 (1536)	814 (1795)	985 (2172)	497 (1097)	570 (1257)	739 (1630)	383 (845)	435 (958)	591 (1303)	307 (677)	347 (765)	478 (1054)	254 (560)	286 (630)
-1.0 m (-3.3 ft)	1199 (2645)	704 (1552)	822 (1812)	875 (1930)	495 (1092)	568 (1252)	664 (1464)	380 (837)	431 (951)	-	-	-	482 (1062)	310 (683)	349 (770)

**05 cab, short stick**

A \ B	2 m (79")			2.5 m (98")			3 m (9'-10")			3.5 m (11'-6")			max		
	I	II	III	I	II	III	I	II	III	I	II	III	I	II	III
3.0 m (9.8 ft)	-	-	-	-	-	-	505 (1113)	420 (926)	473 (1042)	-	-	-	521 (1150)	382 (843)	430 (948)
2.0 m (6.6 ft)	-	-	-	603 (1329)	552 (1217)	603 (1330)	538 (1187)	409 (901)	461 (1016)	505 (1113)	314 (693)	354 (780)	502 (1107)	275 (607)	310 (684)
1.0 m (3.3 ft)	-	-	-	895 (1973)	488 (1075)	559 (1233)	681 (1501)	374 (825)	425 (937)	569 (1255)	296 (654)	335 (739)	507 (1118)	244 (539)	276 (609)
0.0 m (0.0 ft)	1398 (3083)	641 (1413)	753 (1661)	992 (2188)	456 (1005)	525 (1158)	750 (1654)	351 (774)	401 (884)	597 (1316)	283 (623)	321 (707)	517 (1141)	252 (556)	286 (630)
-1.0 m (-3.3 ft)	1105 (2437)	654 (1442)	767 (1692)	826 (1822)	460 (1013)	529 (1167)	622 (1371)	354 (780)	403 (890)	-	-	-	512 (1128)	319 (703)	362 (798)

**06 cab, long stick**

A \ B	2 m (79")			2.5 m (98")			3 m (9'-10")			3.5 m (11'-6")			max		
	I	II	III	I	II	III	I	II	III	I	II	III	I	II	III
3.0 m (9.8 ft)	-	-	-	-	-	-	434 (957)	426 (939)	434 (957)	-	-	-	470 (1035)	334 (736)	376 (828)
2.0 m (6.6 ft)	-	-	-	-	-	-	486 (1071)	411 (906)	464 (1022)	462 (1019)	315 (695)	355 (782)	459 (1012)	249 (550)	281 (620)
1.0 m (3.3 ft)	-	-	-	832 (1835)	492 (1085)	564 (1244)	641 (1414)	374 (825)	425 (937)	541 (1192)	294 (649)	333 (735)	466 (1027)	223 (491)	252 (556)
0.0 m (0.0 ft)	1436 (3167)	632 (1393)	744 (1640)	985 (2172)	450 (993)	520 (1147)	739 (1630)	346 (763)	396 (873)	591 (1303)	277 (611)	315 (695)	478 (1054)	228 (503)	259 (571)
-1.0 m (-3.3 ft)	1199 (2645)	639 (1409)	751 (1657)	875 (1930)	448 (988)	518 (1142)	664 (1464)	343 (756)	393 (866)	-	-	-	482 (1062)	279 (616)	318 (700)

**07 cab, short stick, additional weight**

A \ B	2 m (79")			2.5 m (98")			3 m (9'-10")			3.5 m (11'-6")			max		
	I	II	III	I	II	III	I	II	III	I	II	III	I	II	III
3.0 m (9.8 ft)	-	-	-	-	-	-	505 (1113)	476 (1049)	505 (1114)	-	-	-	521 (1150)	434 (957)	487 (1075)
2.0 m (6.6 ft)	-	-	-	603 (1329)	603 (1330)	603 (1330)	538 (1187)	464 (1023)	522 (1151)	505 (1113)	360 (794)	404 (890)	502 (1107)	317 (699)	356 (785)
1.0 m (3.3 ft)	-	-	-	895 (1973)	558 (1231)	638 (1408)	681 (1501)	430 (947)	486 (1072)	569 (1255)	342 (754)	385 (849)	507 (1118)	284 (626)	319 (704)
0.0 m (0.0 ft)	1398 (3083)	738 (1628)	865 (1907)	992 (2188)	526 (1160)	604 (1333)	750 (1654)	407 (896)	462 (1019)	597 (1316)	328 (724)	371 (818)	517 (1141)	294 (647)	331 (730)
-1.0 m (-3.3 ft)	1105 (2437)	751 (1657)	879 (1938)	826 (1822)	530 (1169)	609 (1342)	622 (1371)	409 (902)	465 (1025)	-	-	-	512 (1128)	369 (813)	417 (920)

**08 cab, long stick, additional weight**

A \ B	2 m (79")			2.5 m (98")			3 m (9'-10")			3.5 m (11'-6")			max		
	I	II	III	I	II	III	I	II	III	I	II	III	I	II	III
3.0 m (9.8 ft)	-	-	-	-	-	-	434 (957)	434 (957)	434 (957)	-	-	-	470 (1035)	381 (840)	428 (943)
2.0 m (6.6 ft)	-	-	-	-	-	-	486 (1071)	466 (1029)	486 (1072)	462 (1019)	361 (795)	405 (892)	459 (1012)	288 (636)	324 (715)
1.0 m (3.3 ft)	-	-	-	832 (1835)	563 (1241)	643 (1418)	641 (1414)	429 (947)	486 (1073)	541 (1192)	340 (749)	383 (845)	466 (1027)	260 (573)	293 (645)
0.0 m (0.0 ft)	1436 (3167)	729 (1608)	855 (1886)	985 (2172)	521 (1149)	599 (1322)	739 (1630)	402 (886)	457 (1009)	591 (1303)	322 (711)	365 (806)	478 (1054)	267 (588)	301 (665)
-1.0 m (-3.3 ft)	1199 (2645)	736 (1624)	863 (1903)	875 (1930)	519 (1144)	597 (1317)	664 (1464)	398 (878)	454 (1001)	-	-	-	482 (1062)	325 (716)	368 (811)

**09 cab, short stick, VDS**

A B	2 m (79")			2.5 m (98")			3 m (9'-10")			3.5 m (11'-6")			max		
	I	II	III	I	II	III	I	II	III	I	II	III	I	II	III
3.0 m (9.8 ft)	-	-	-	-	-	-	495 (1093)	464 (1022)	495 (1091)	-	-	-	516 (1137)	403 (889)	444 (978)
2.0 m (6.6 ft)	-	-	-	628 (1385)	599 (1322)	628 (1385)	549 (1212)	448 (987)	494 (1090)	508 (1121)	348 (767)	382 (843)	501 (1105)	303 (667)	333 (733)
1.0 m (3.3 ft)	-	-	-	912 (2010)	536 (1181)	601 (1325)	690 (1522)	413 (910)	458 (1010)	573 (1264)	329 (726)	363 (801)	507 (1119)	275 (606)	303 (667)
0.0 m (0.0 ft)	1366 (3013)	715 (1578)	821 (1809)	979 (2159)	509 (1121)	572 (1261)	743 (1638)	392 (865)	437 (963)	589 (1299)	317 (699)	351 (773)	517 (1141)	289 (637)	319 (703)
-1.0 m (-3.3 ft)	1044 (2302)	731 (1612)	838 (1847)	783 (1727)	516 (1137)	580 (1278)	579 (1276)	399 (879)	444 (978)	-	-	-	506 (1116)	375 (827)	416 (917)

**10 cab, long stick, VDS**

A B	2 m (79")			2.5 m (98")			3 m (9'-10")			3.5 m (11'-6")			max		
	I	II	III	I	II	III	I	II	III	I	II	III	I	II	III
3.0 m (9.8 ft)	-	-	-	-	-	-	430 (948)	430 (948)	430 (948)	-	-	-	466 (1027)	356 (785)	391 (863)
2.0 m (6.6 ft)	-	-	-	-	-	-	498 (1098)	450 (992)	497 (1096)	468 (1031)	348 (767)	383 (845)	458 (1011)	275 (607)	303 (668)
1.0 m (3.3 ft)	-	-	-	855 (1885)	539 (1189)	605 (1333)	654 (1441)	412 (909)	458 (1010)	547 (1206)	327 (720)	361 (796)	466 (1028)	251 (553)	277 (610)
0.0 m (0.0 ft)	1410 (3109)	705 (1555)	810 (1787)	977 (2155)	503 (1108)	566 (1249)	736 (1623)	387 (853)	431 (951)	587 (1295)	311 (685)	344 (760)	478 (1055)	262 (577)	289 (638)
-1.0 m (-3.3 ft)	1145 (2524)	715 (1578)	821 (1811)	840 (1851)	504 (1110)	567 (1251)	635 (1399)	387 (853)	431 (951)	-	-	-	479 (1055)	328 (722)	363 (801)

**11 cab, short stick, additional weight, VDS**

A \ B	2 m (79")			2.5 m (98")			3 m (9'-10")			3.5 m (11'-6")			max		
	I	II	III	I	II	III	I	II	III	I	II	III	I	II	III
3.0 m (9.8 ft)	-	-	-	-	-	-	495 (1093)	495 (1091)	495 (1091)	-	-	-	516 (1137)	454 (1002)	497 (1096)
2.0 m (6.6 ft)	-	-	-	628 (1385)	628 (1385)	628 (1385)	549 (1212)	504 (1112)	549 (1211)	508 (1121)	394 (869)	431 (949)	501 (1105)	345 (760)	376 (829)
1.0 m (3.3 ft)	-	-	-	912 (2010)	608 (1340)	677 (1492)	690 (1522)	469 (1035)	517 (1140)	573 (1264)	376 (828)	411 (907)	507 (1119)	315 (695)	344 (758)
0.0 m (0.0 ft)	1366 (3013)	815 (1797)	927 (2045)	979 (2159)	581 (1280)	648 (1429)	743 (1638)	449 (990)	496 (1093)	589 (1299)	363 (801)	399 (879)	517 (1141)	331 (731)	363 (800)
-1.0 m (-3.3 ft)	1044 (2302)	830 (1831)	944 (2082)	783 (1727)	588 (1296)	656 (1446)	579 (1276)	455 (1004)	502 (1108)	-	-	-	506 (1116)	428 (944)	471 (1039)

**12 cab, long stick, additional weight, VDS**

A \ B	3.5 m (11'-6")			3.0 m (9'-10")			2.5 m (98")			2 m (79")			max		
	I	II	III	I	II	III	I	II	III	I	II	III	I	II	III
3.0 m (9.8 ft)	-	-	-	-	-	-	430 (948)	430 (948)	430 (948)	-	-	-	466 (1027)	403 (888)	440 (970)
2.0 m (6.6 ft)	-	-	-	-	-	-	498 (1098)	498 (1098)	498 (1098)	468 (1031)	394 (870)	431 (951)	458 (1011)	315 (694)	344 (757)
1.0 m (3.3 ft)	-	-	-	855 (1885)	611 (1347)	681 (1501)	654 (1441)	469 (1034)	517 (1139)	547 (1206)	373 (823)	409 (902)	466 (1028)	289 (637)	316 (696)
0.0 m (0.0 ft)	1410 (3109)	805 (1774)	917 (2022)	977 (2155)	575 (1267)	642 (1416)	736 (1623)	443 (978)	490 (1081)	587 (1295)	357 (788)	393 (866)	478 (1055)	302 (665)	330 (728)
-1.0 m (-3.3 ft)	1145 (2524)	815 (1797)	928 (2046)	840 (1851)	576 (1269)	643 (1418)	635 (1399)	443 (977)	490 (1081)	-	-	-	479 (1055)	376 (828)	413 (911)



---

## Safety instructions load diagrams

Observe the values of the load diagrams in lifting gear applications.

---

### **DANGER**

#### **Crushing hazard due to tipping over of vehicle!**

The vehicle causes serious injury or death when it tips over.

- ▶ Do not exceed the weights indicated in the load diagrams.
  - ▶ Subtract the weight of the attachment from the weight specified in the relevant load diagram.
  - ▶ Use the vehicle for lifting gear applications only if the mandatory lifting gear and safety equipment is installed, functional and enabled.
  - ▶ Do not tilting the upper carriage.
- 

### **NOTICE**

If the weight is exceeded, there is a risk of damage to property if the vehicle tips over.

- ▶ Do not exceed the weights indicated in the load diagrams.
- 

### **Information**

The indications are only approximate values. Attachments, uneven ground and soft or bad ground conditions affect the vehicle's stability, and thus the weight and mass it can handle. The operator must take these influences into account.

---

**Legend**

Designation	Explanation
X	Reach from live ring center
Z	Load hook height in the respective range
max	Authorized lift capacity with horizontal boom
L	Stick short/long

Authorized lift capacity applies to entire swiveling range of 360°.

All table indications in kg (lbs.) and horizontal position on firm and level ground without bucket or exchangeable attachment.

The vehicle's lift capacity is restricted by the settings of the pressure limiting valves, the hydraulic output and the hydraulic system's stabilizing features.

Neither 75% of the static tilt load nor 87% of the hydraulic lift capacity is exceeded.

Calculation basis: according to ISO 10567

Setting pressure on boom cylinder: 22,500 kPa (3,263 psi)

Lift capacities apply to vehicles under the following conditions:

- Lubricants and engine/vehicle fluids at the mandatory levels
- Full fuel tank
- Cabin or canopy
- Machine at operating temperature
- Operator weight 75 kg (165 lbs.)

Canopy/cabin

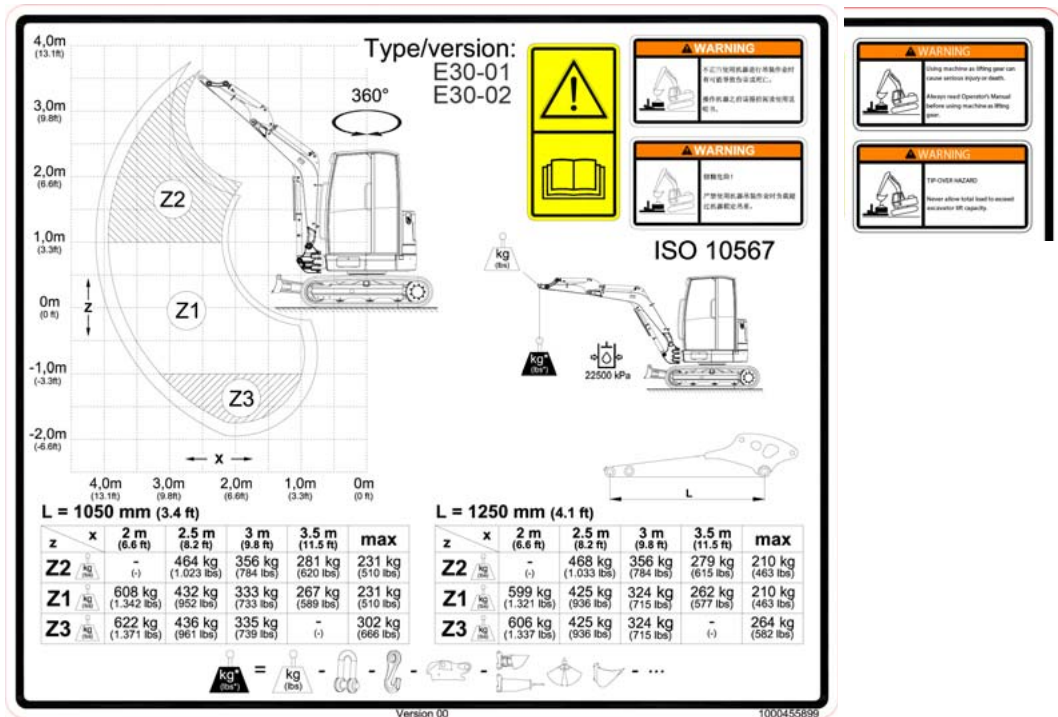

Symbolic representation

Canopy/cabin with extra weight

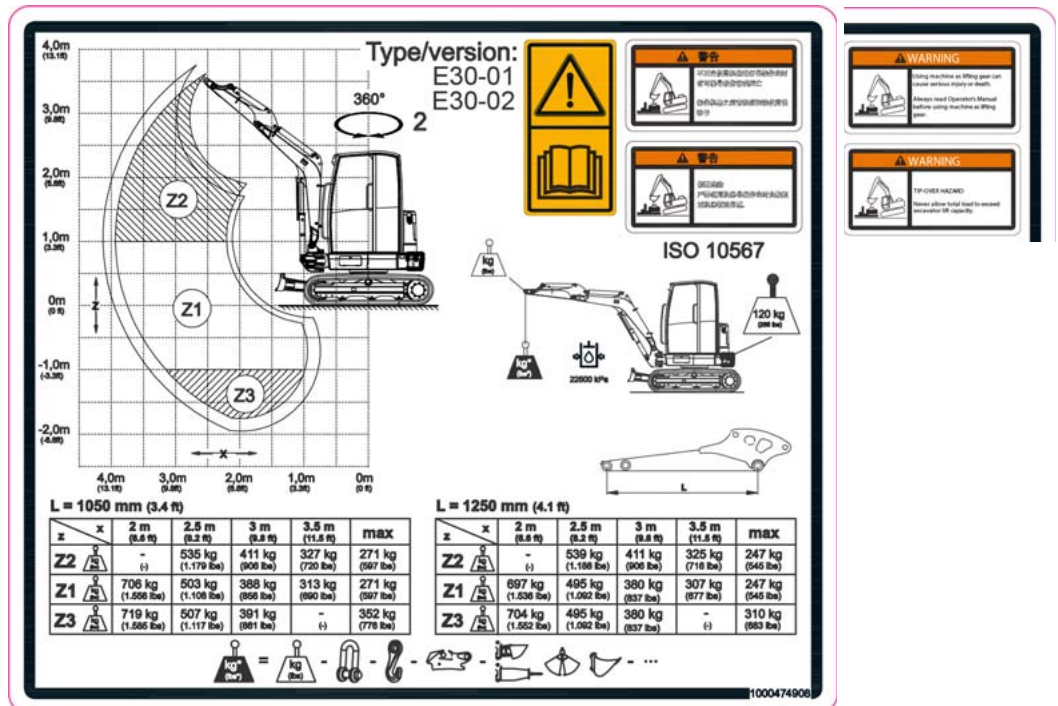

Symbolic representation

## 9.15 Dimensions

### EZ25

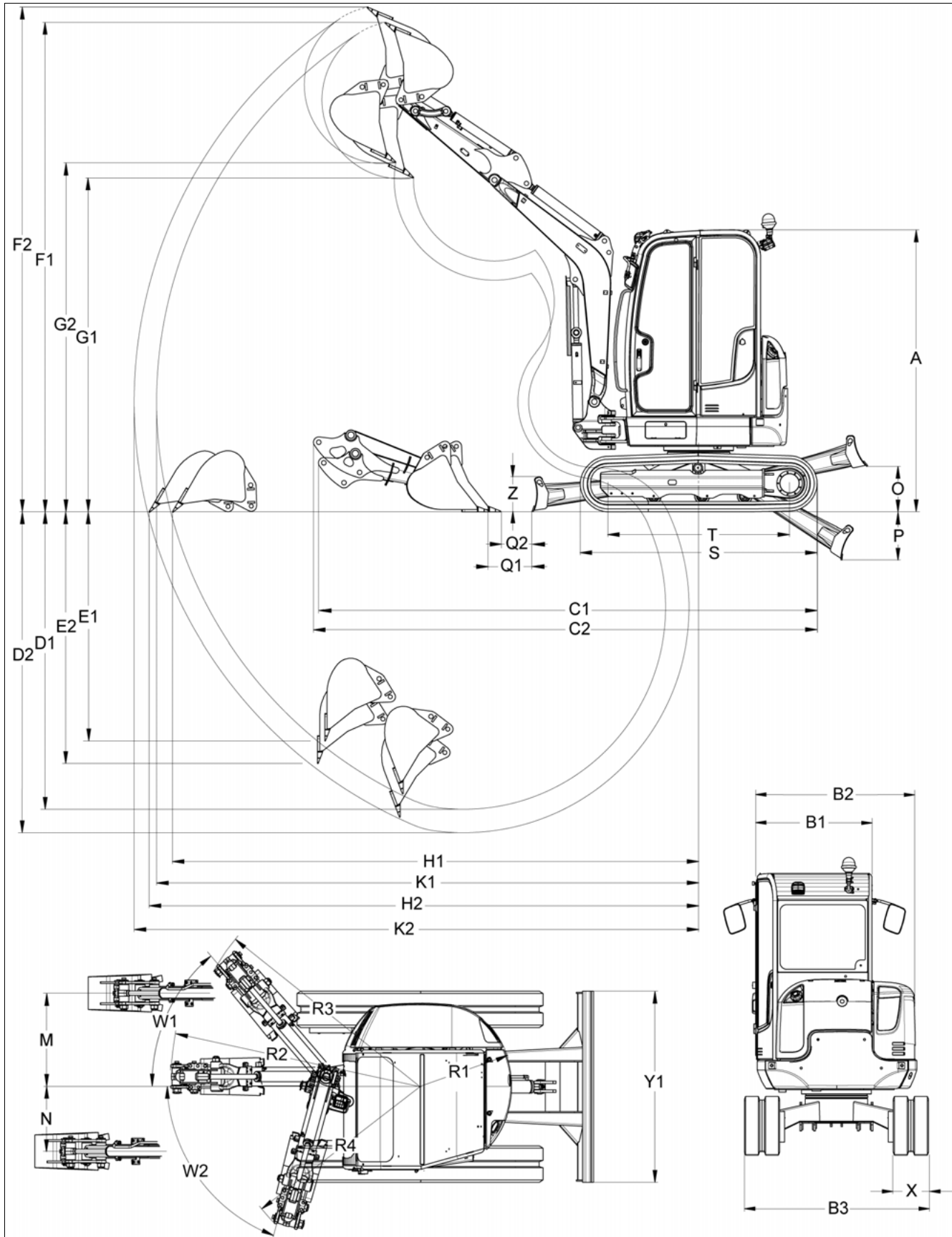



<b>EZ25</b>		
A	Height	2414 mm (95 in)
B1	Cabin width	986 mm (39 in)
B2	Upper carriage width	1366 mm (54 in)
B3	Travel gear width	1570 mm (62 in)
C1	Transport length (short stick)	4266 mm (14')
C2	Transport length (long stick)	4290 mm (14'-1")
D1	Max. digging depth (short stick)	2537 mm (8'-4" in)
D2	Max. digging depth (long stick)	2737 mm (9'-0")
E1	Max. vertical digging depth (short stick)	1949 mm (77 in)
E2	Max. vertical digging depth (long stick)	2139 mm (84 in)
F1	Max. digging height (short stick)	4176 mm (13'-8")
F2	Max. digging height (long stick)	4306 mm (14'-2")
G1	Max. tilt-out height (short stick)	2847 mm (9'-4")
G2	Max. tilt-out height (long stick)	2977 mm (9'-9")
H1	Max. reach at ground level (short stick)	4490 mm (14'-9")
H2	Max. reach at ground level (long stick)	4690 mm (15'-5")
K1	Max. digging radius (short stick)	4624 mm (15'-2")
K2	Max. digging radius (long stick)	4816 mm (15'-10")
M	Max. boom displacement to bucket center (right side)	765 mm (30 in)
N	Max. boom displacement to bucket center (left side)	531 mm (21 in)
O	Max. lift height of stabilizer blade over ground	387 mm (15 in)
P	Max. scraping depth of stabilizer blade below ground surface	412 mm (16 in)
Q1	Distance between bucket and stabilizer blade (short stick)	363 mm (14 in)
Q2	Distance between bucket and stabilizer blade (long stick)	267 mm (11 in)
R1	Min. tail end swiveling radius	770 mm (30 in)
R2	Boom swivel radius (center)	2082 mm (82 in)
R3	Boom swivel radius (right)	1964 mm (77 in)
R4	Boom swivel radius (left)	1660 mm (65 in)
S	Total running gear length	2021 mm (80 in)
T	Running gear length (Turas front idler)	1548 mm (61 in)
W1	Max. tilting angle of boom to the right	50°
W2	Max. tilting angle of boom to the left	75°
X	Track width	300 mm (12 in)
Y1	Stabilizer blade width	1570 mm (62 in)
Z	Stabilizer blade height	300 mm (12 in)

EZ25 VDS

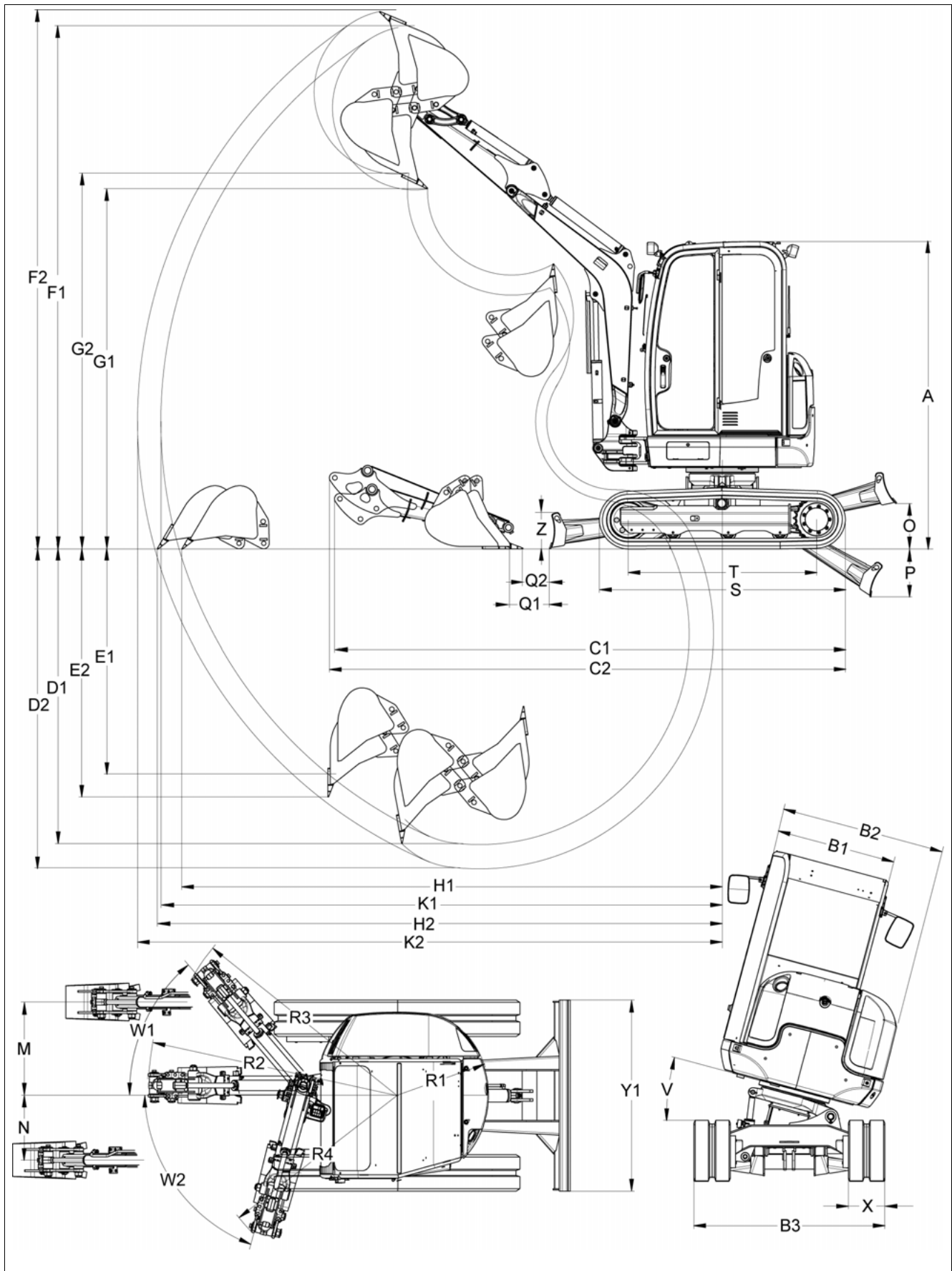

EZ25 VDS		
A	Height	2524 mm (99 in)
B1	Cabin width	980 mm (39 in)
B2	Upper carriage width	1340 mm (53 in)
B3	Travel gear width	1570 mm (62 in)
C1	Transport length (short stick)	4211 mm (13'-10")
C2	Transport length (long stick)	4253 mm (13'-11")
D1	Max. digging depth (short stick)	2427 mm (96 in)
D2	Max. digging depth (long stick)	2627 mm (8'-7")
E1	Max. vertical digging depth (short stick)	1839 mm (72 in)
E2	Max. vertical digging depth (long stick)	2029 mm (80 in)
F1	Max. digging height (short stick)	4286 mm (14'-0")
F2	Max. digging height (long stick)	4416 mm (14'-6")
G1	Max. tilt-out height (short stick)	2957 mm (9'-8")
G2	Max. tilt-out height (long stick)	3087 mm (10'-2")
H1	Max. reach at ground level (short stick)	4473 mm (14'-8")
H2	Max. reach at ground level (long stick)	4673 mm (15'-4")
K1	Max. digging radius (short stick)	4630 mm (15'-2")
K2	Max. digging radius (long stick)	4820 mm (15'-10")
M	Max. boom displacement to bucket center (right side)	765 mm (30 in)
N	Max. boom displacement to bucket center (left side)	535 mm (21 in)
O	Max. lift height of stabilizer blade over ground	390 mm (15 in)
P	Max. scraping depth of stabilizer blade below ground surface	410 mm (16 in)
Q1	Distance between bucket and stabilizer blade (short stick)	331 mm (13 in)
Q2	Distance between bucket and stabilizer blade (long stick)	233 mm (9 in)
R1	Min. tail end swiveling radius	760 mm (30 in)
R2	Boom swivel radius (center)	2080 mm (82 in)
R3	Boom swivel radius (right)	1960 mm (77 in)
R4	Boom swivel radius (left)	1660 mm (65 in)
S	Total running gear length	2020 mm (80 in)
T	Running gear length (Turas front idler)	1550 mm (61 in)
V	Angle of inclination VDS	15°
W1	Max. tilting angle of boom to the right	50°
W2	Max. tilting angle of boom to the left	75°
X	Track width	300 mm (12 in)
Y1	Stabilizer blade width	1570 mm (62 in)
Z	Stabilizer blade height	300 mm (12 in)



Notes:



# Index

## Numerisch

12 V connection ..... 4-22

## A

Abbreviations ..... 1-3  
 Adding engine oil ..... 7-29  
 Adding hydraulic oil ..... 7-38  
 Additional control circuit – AUX I ..... 5-17, 5-25  
 Adjusting the seat belt ..... 4-11  
 Air conditioning ..... 7-41  
 Air filter ..... 7-33  
 Air intake ..... 7-33  
 Arm rest ..... 4-15  
 Attachments ..... 5-37, 9-10  
     Picking up ..... 5-37  
     Setting down ..... 5-38  
 Automatic engine speed setting ..... 5-3  
 AUX V ..... 5-36

## B

Battery ..... 7-41  
 Battery master switch ..... 4-43  
 Bleeding the fuel system ..... 7-27  
 Boom light ..... 5-11  
 Brake ..... 5-3, 9-2  
     Hydraulic brake ..... 5-3  
     Mechanical brake ..... 5-3  
 Brief description of the vehicle ..... 3-2  
 Bucket operation ..... 5-36  
 Bucket position when digging ..... 5-54  
 Bulbs ..... 9-6

## C

Cab ..... 4-1  
 Cabin number ..... 3-7  
 Cabin overview ..... 4-24  
 Charge indicator light ..... 4-29  
 Check and top off the coolant ..... 7-31  
 Check belt tension ..... 7-35  
 Check lists for starting/operation/parking ..... 4-32  
 Check the hydraulic oil level ..... 7-37  
 Checking the engine-oil level ..... 7-29  
 Checking the fluid level ..... 7-41  
 Checking the water separator ..... 7-25  
 Cleaning and maintenance ..... 7-18  
 Cleaning the radiator ..... 7-32  
 Control lever base ..... 4-37  
 Conversion table ..... 1-7  
 Coolant  
     Compound table ..... 9-8  
 Cooling system ..... 7-30  
 Crane-lifting ..... 6-5

## D

Danger zone ..... 5-42

Danger zone during lifting-gear applications ..... 5-43  
 Designated use ..... 3-4  
 Diesel engine malfunctions ..... 8-1  
 Diesel fuel specification ..... 7-22  
 Differential lock ..... 5-9  
 Dimensions  
     EZ25 ..... 9-24  
     EZ25 VDS ..... 9-26  
 Display element ..... 4-28  
 Displaying coolant temperature ..... 4-29  
 Displaying fuel level indicator ..... 4-30  
 Disposal ..... 5-63  
 Document box ..... 4-22  
 Downhill vehicle operation ..... 5-8  
 Drive interlock ..... 5-58

## E

Electrical components ..... 9-3  
 Electrical system ..... 7-40  
 Emergency exit ..... 4-8  
 Emergency lowering ..... 5-57  
 Empty the water separator (main filter) ..... 7-26  
 Empty the water separator (prefilter) ..... 7-25  
 Engine data ..... 9-1  
 Engine lubrication system ..... 7-28  
 Engine oil pressure ..... 4-29  
 Engine start  
     Starting aid ..... 4-39  
 Excavator forces ..... 9-12  
 Explanation of symbols ..... 1-2

## F

Fire extinguisher ..... 4-15  
 Fluids and lubricants ..... 7-13  
 Foreword ..... 1-1  
 Front Guard emergency exit ..... 4-8  
 Fuel system ..... 7-22  
 Functional check  
     Control lever base ..... 4-37  
     Swivel unit brake ..... 5-19

## G

Getting on and off ..... 4-2  
 Glossary ..... 1-4  
     Right/left/front/rear ..... 1-5  
 Grab operation ..... 5-36  
 Grading ..... 5-55  
 Ground clearance ..... 9-12  
 Ground pressure ..... 9-12

## H

Hammer ..... 5-22  
 Hammer operation ..... 5-22  
     Job site ..... 5-23  
 Heating ..... 7-41  
 Horizontal seat adjustment ..... 4-10

Horn .....	5-11	Machine travel position .....	5-4
Hydraulic connections .....	5-40	Maintenance	
Hydraulic oil changing intervals for hammer operation 7-14		Maintenance meter .....	4-30
Hydraulic oil types .....	7-14	Maintenance accesses .....	7-16
Hydraulic quickhitch .....	5-28	Maintenance flap .....	7-17
Picking up an attachment .....	5-29	Maintenance label .....	7-2
Setting down an attachment .....	5-33	Maintenance of attachments .....	7-45
Hydraulic swivel unit brake .....	5-19	Maintenance of the electrical system .....	7-40
Hydraulic system .....	7-35	Maintenance plan .....	7-3
Hydraulics		Mechanical quickhitch .....	7-6
Checking the hydraulic system and hoses .....	7-39	Malfunction .....	8-1
<b>I</b>		Malfunctions of the hydraulic system .....	8-2
Ignition lock .....	4-36	Manual throttle .....	5-2
Inadmissible work procedures .....	5-51	Maximum speed .....	9-2
Indicator lights and warning lights (overview) .....	4-28	Mechanical quickhitch	
Information and regulations on use .....	3-4	Picking up an attachment .....	5-48
Information before putting into operation .....	4-31	Setting down an attachment .....	5-50
Information label .....	3-12	Mechanical quickhitch (option) .....	5-47
Information on this Operator's Manual .....	1-1	Model designations and trade names .....	3-2
Information regarding operation with bio-hydraulic oil .. 7-14		<b>N</b>	
Interior light .....	5-11	Noise emissions .....	9-8
Introduction .....	3-1	<b>O</b>	
ISO/SAE controls (option) .....	5-16	Opening/closing the engine hood .....	7-17
<b>L</b>		Opening/closing the front window .....	4-4
Labels .....	3-5	Opening/closing the side window .....	4-7
Letting the engine warm up .....	4-38	Operating limits .....	5-5
Lift capacity tables .....	9-12	Operating Pattern A/B .....	5-16
Lift capacity/load .....	9-12	Operating temperature range .....	5-5
Lift capacity tables .....	9-15	Operation .....	5-1
Lifting eyes .....	6-6	Operation in water .....	5-53
Lifting gear applications		Operation near the sea .....	5-53
Safe load indicator .....	5-45	Options .....	5-58
Lights .....	5-10	Overview of control elements .....	4-23
Load diagrams .....	9-21	<b>P</b>	
Loading .....	6-2	Parking the vehicle .....	5-9
Loading material .....	5-55	Parking the vehicle on slopes .....	5-9
Loading the vehicle .....	6-2	Permanently putting out of operation .....	5-63
Loading vehicles .....	5-55	Powertilt .....	9-6
Locking/unlocking the door on the left .....	4-31	Preheating .....	4-29
Low-load operation .....	4-42	Preparations for starting the engine .....	4-36
Lubrication		Preparatory work for putting into operation .....	4-31
Control lever base .....	7-12	Proportional controls .....	5-25
Live ring (ball bearing) .....	7-10	Protective structures .....	4-16
Lubrication plan .....	7-8	Putting back into operation .....	5-62
Machine operation in water .....	7-12	Putting into operation for the first time and running-in period .....	4-35
Preparatory work .....	7-7	Putting out of operation temporarily .....	5-61
Teeth of live ring VDS .....	7-11	<b>R</b>	
Vehicle lubrication plan .....	7-8	Reducing track tension .....	7-44
<b>M</b>		Re-equipping .....	5-41
Machine overview .....	3-1	Refueling .....	7-23
Machine travel .....	5-4	Refueling with a stationary fuel pump .....	7-24
Starting vehicle travel and stopping .....	5-4	Release the pressure of the work hydraulics .....	5-39
Machine travel and stopping .....	5-4	Replacing the cabin air filter .....	7-41
		Requirements for the operating personnel .....	4-32

Rotating beacon .....	5-12	Working lights .....	5-10
Rotating the upper carriage .....	5-18	Working on slopes .....	5-56
<b>S</b>		Working with a hydraulic hammer .....	5-23
Safe load indicator			
Functional check .....	5-46		
Seat .....	4-9		
Adjusting the backrest .....	4-10		
Adjusting the weight .....	4-10		
Serial .....	3-5		
Shovel bucket operation .....	5-60		
Signaling system .....	5-10		
Stabilizer blade .....	5-21		
Starting aid .....	4-39		
Starting and stopping the engine .....	4-36		
Starting vehicle travel and stopping .....	5-4		
Starts the engine .....	4-37		
Steering system .....	5-1, 9-2		
Stop the engine .....	4-42		
Switches .....	4-26		
Swivel unit brake .....	5-19		
Swiveling the boom .....	5-17		
<b>T</b>			
Tie-down points .....	6-3		
Tightening torques .....	9-7		
Tilt the superstructure with VDS .....	5-59		
Towing .....	6-1		
Transportation .....	6-1		
Transporting the vehicle .....	6-7		
Travel drive .....	7-41, 9-2		
Troubleshooting on the Powertilt unit .....	8-2		
Type labels .....	3-5		
<b>U</b>			
Unlocking and locking the door .....	4-3		
Uphill vehicle operation .....	5-8		
<b>V</b>			
V-belt .....	7-34		
VDS .....	5-59		
Ventilation .....	7-41		
Vertical Digging System .....	5-59		
Vibration .....	9-9		
Visual aids .....	4-13		
<b>W</b>			
Warning label .....	3-8		
Warranty and liability .....	1-8		
Washer system .....	5-13, 7-41		
Weight			
Attachments .....	9-11		
Loading weight .....	9-9		
vehicle .....	9-9		
Wiper/wash system .....	5-13		
Work hydraulics .....	5-15, 9-2		
Work operation .....	5-42		
Work position of vehicle .....	5-54		
Working alongside trenches .....	5-54		



Wacker Neuson Linz GmbH keep abreast of the latest technical developments and constantly improve their products. For this reason, we may from time to time need to make changes to figures and descriptions in this documentation that do not reflect products that have already been delivered and that will not be implemented on these vehicles.

Technical data, dimensions and weights are only given as an indication. Responsibility for errors or omissions not accepted.

No reproduction or translation of this publication, in whole or in part, without the written consent from Wacker Neuson Linz GmbH.

All rights under the provision of the Copyright Act are reserved.

Wacker Neuson Linz GmbH

Flughafenstr. 7

A-4063 Hörsching

Austria



**WACKER  
NEUSON**

**Wacker Neuson (China)  
Machinery Co., Ltd.**

No.1688 Xinkai Road, Pinghu Economic  
Development Zone  
Pinghu City, Zhejiang Province, P.R Chi-  
na  
Zip code: 314200

Phone: +86 (0) 0573 - 85820666  
Fax: +86 (0) 0573 - 85820555  
E-mail: [china@wackerneuson.com](mailto:china@wackerneuson.com)  
[www.wackerneuson.com](http://www.wackerneuson.com)

Order no. 1000488864  
Language en