

STIHL[®]

STIHL BT 130

Instruction Manual



Contents

Guide to Using this Manual	2
Safety Precautions and Working Techniques	2
Assembling the Unit	7
Adjusting the Throttle Cable	7
4-MIX Engine	8
Fuel	8
Fueling	9
Auger Brake	10
Fitting the Auger	11
Starting / Stopping the Engine	11
Operating Instructions	14
Releasing a Trapped Auger	14
Replacing the Air Filter	15
Adjusting the Carburetor	15
Spark Plug	16
Engine Running Behavior	17
Lubricating the Gearbox	17
Rewind Starter	17
Storing the Machine	18
Inspections and Maintenance by Dealer	18
Maintenance and Care	19
Minimize Wear and Avoid Damage	21
Main Parts	22
Specifications	23
Special Accessories	24
Maintenance and Repairs	24
Disposal	24
EC Declaration of Conformity	25

Dear Customer,

Thank you for choosing a quality engineered STIHL product.

It has been built using modern production techniques and comprehensive quality assurance. Every effort has been made to ensure your satisfaction and troublefree use of the product.

Please contact your dealer or our sales company if you have any queries concerning this product.

Your



Dr. Nikolas Stihl

STIHL®

This instruction manual is protected by copyright. All rights reserved, especially the rights to reproduce, translate and process with electronic systems.

Guide to Using this Manual

Pictograms

Pictograms that appear on the machine are explained in this Instruction Manual.

Depending on the machine and equipment version, the following pictograms may appear on the machine.



Fuel tank; fuel mixture of gasoline and engine oil

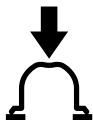

Actuate fuel pump



Auger brake

Symbols in text



WARNING

Warning where there is a risk of an accident or personal injury or serious damage to property.



NOTICE

Caution where there is a risk of damaging the machine or its individual components.

Engineering improvements

STIHL's philosophy is to continually improve all of its products. For this reason we may modify the design, engineering and appearance of our products periodically.

Therefore, some changes, modifications and improvements may not be covered in this manual.

Safety Precautions and Working Techniques



Special safety precautions must be observed when working with this power tool because of its high torque and the high speed of the auger in certain applications, and because the augers have sharp edges.



It is important that you read the instruction manual before first use and keep it in a safe place for future reference. Non-observance of the instruction manual may result in serious or even fatal injury.



Observe all applicable local safety regulations, standards and ordinances.

If you have not used this type of power tool before: Have your dealer or other experienced user show you how to operate your unit or attend a special course in its operation.

Minors should never be allowed to use a power tool.

Keep bystanders, especially children, and animals away from the work area.

When the power tool is not in use, shut it off so that it does not endanger others. Secure it against unauthorized use.

The user is responsible for avoiding injury to third parties or damage to their property.

Do not lend or rent your power tool without the instruction manual. Be sure that anyone using it understands the information contained in this manual.

The use of noise emitting power tools may be restricted to certain times by national or local regulations.

To operate the power tool you must be rested, in good physical condition and mental health.

If you have any condition that might be aggravated by strenuous work, check with your doctor before operating a power tool.

Persons with pacemakers only: The ignition system of your power tool produces an electromagnetic field of a very low intensity. This field may interfere with some pacemakers. STIHL recommends that persons with pacemakers consult their physician and the pacemaker manufacturer to reduce any health risk.

Do not operate the power tool if you are under the influence of any substance (drugs, alcohol) which might impair vision, dexterity or judgment.

Use your power tool only for drilling holes in soil and wood – depending on the drilling tool mounted. Select drilling axis so that the auger brake lever is always in a position to be activated by the operator's thigh.

Do not use your power tool for any other purpose.

Before drilling, make sure there are no buried power cables or supply pipes in the work area (e.g. for gas, water, electricity):

- Contact your local utility company for information on cable and pipe locations.
- Where necessary, confirm actual location with cable detectors and/or by carefully dug trenches.

Only use drilling tools and accessories that are explicitly approved for this power tool by STIHL or are technically identical. If you have any questions in this respect, consult a servicing dealer. Use only high quality tools and accessories. In order to avoid the risk of accidents and damage to the machine.

STIHL recommends the use of genuine STIHL tools and accessories. They are specifically designed to match the product and meet your performance requirements.

Never attempt to modify your unit in any way since this may increase the risk of personal injury. STIHL excludes all liability for personal injury and damage to property caused while using unauthorized attachments.

Do not use a pressure washer to clean the unit. The solid jet of water may damage parts of the unit.

Clothing and Equipment

Wear proper protective clothing and equipment.



Clothing must be sturdy but allow complete freedom of movement. Wear snug-fitting clothing, an overall and jacket combination, do not wear a work coat.

Avoid clothing that could get caught on branches or brush or moving parts of the machine. Do not wear a scarf, necktie or jewelry.



Tie up and confine long hair (e.g. with a hair net, cap, hard hat, etc.).



Wear sturdy shoes with non-slip soles.



Wear safety glasses or other suitable eye protection. Wear hearing protection, e.g. earplugs or ear muffs.

Wear a safety hard hat where there is a danger of head injuries from falling objects.



Wear heavy-duty work gloves made of durable material (e.g. leather).

STIHL offers a comprehensive range of personal protective clothing and equipment.

Transporting the Power Tool

Always turn off the engine.

Remove the auger before transporting the power tool long distances. **To reduce the risk of burn injury**, carry the unit by the handle frame with hot parts of the machine (e.g. gearbox) away from your body.

In vehicles: Properly secure your power tool to prevent turnover, fuel spillage and damage.

Fueling



Gasoline is an extremely flammable fuel. Keep clear of naked flames. Do not spill any fuel – do not smoke.

Always **shut off the engine** before refueling.

Do not fuel a hot engine – **fuel may spill and cause a fire.**

Open the fuel cap carefully to allow any pressure build-up in the tank to release slowly and avoid fuel spillage.

Fuel your power tool only in well-ventilated areas. If you spill fuel, wipe the machine immediately – if fuel gets on your clothing, change immediately.



After fueling, tighten down the screw-type fuel cap as securely as possible.

This reduces the risk of unit vibrations causing the fuel cap to loosen or come off and spill quantities of fuel.



Check for leakage. To reduce the **risk of serious of fatal burn injuries**, do not start or run the engine until leak is fixed.

Before Starting

Check that your power tool is properly assembled and in good condition – refer to appropriate chapters in the instruction manual.

- Check the fuel system for leaks, paying special attention to visible parts such as the tank cap, hose connections and the manual fuel pump (on machines so equipped). If there are any leaks or damage, do not start the engine – **risk of fire**. Have your machine repaired by a servicing dealer before using it again.
- Slide control / stop switch must move easily to **STOP** or **0**.
- Auger brake in good working order.
- Smooth action of throttle trigger and throttle trigger lockout – throttle trigger must return automatically to idle position.
- Check that the spark plug boot is secure – a loose boot may cause arcing that could ignite combustible fumes **and cause a fire**.
- Never attempt to modify the controls or safety devices in any way.
- Keep the handles dry and clean – free from oil and dirt – for safe control of the power tool.

To reduce the risk of accidents, do not operate your power tool if it is damaged or not properly assembled.

Starting the Engine

Start the engine at least 3 meters from the fueling spot, outdoors only.

Place the unit on level ground, make sure you have secure footing, hold the unit securely. Check that the drilling tool is not touching the ground or any other object since it may begin to rotate when the engine starts.

Your power tool is designed to be operated by one person only. Do not allow other persons in the work area – even when starting. **To reduce the risk of injury**, avoid contact with the drilling tool.

Do not drop start the power tool – start the engine as described in the instruction manual.

Check idle speed setting: The drilling tool must not rotate when the engine is idling with the throttle trigger released.

To reduce the risk of fire, keep hot exhaust gases and hot muffler away from easily combustible materials (e.g. wood chips, bark, dry grass, fuel).

Holding and Controlling the Unit

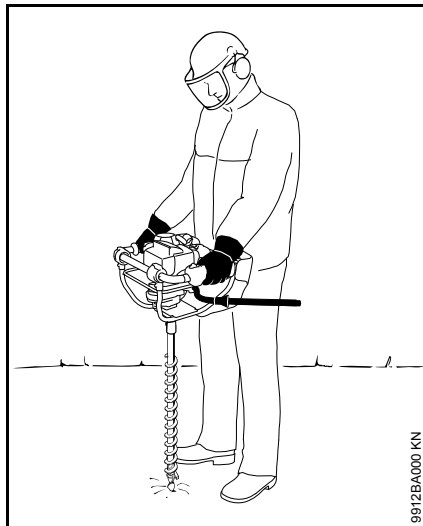

Always hold the power tool firmly with both hands on the handles.

Make sure you always have good balance and secure footing – auger brake lever against your left thigh.

Wrap your fingers and thumbs tightly around the handles – left hand on the control handle.

During Operation

In the event of impending danger or in an emergency, switch off the engine immediately by moving the slide control / stop switch to **0** or **STOP**.

Do not allow any other persons in the work area. To **reduce the risk of injury**, keep a sufficiently safe distance away from other persons.

The correct engine idle speed is important to ensure that the drilling tool stops rotating when you let go of the throttle trigger. If the drilling tool continues to rotate when the engine is idling, have the machine checked by your servicing dealer. Check and correct the idle speed setting regularly.

Take special care in slippery conditions (ice, wet ground, snow), on slopes or uneven ground.

Watch out for obstacles: Roots, tree stumps or holes which **could cause you to trip or stumble**.

Make sure you always have good balance and secure footing.

Be particularly alert and cautious when wearing hearing protection because your ability to hear warnings (shouts, alarms, etc.) is restricted.

To reduce the risk of accidents, take a break in good time to avoid tiredness or exhaustion.

Work calmly and carefully – in daylight conditions and only when visibility is good. Stay alert so as not to endanger others.



Your power tool produces toxic exhaust fumes as soon as the engine is running. These fumes may be colorless and odorless and contain unburned hydrocarbons and benzol. Never run the engine indoors or in poorly ventilated locations, even if your model is equipped with a catalytic converter.

Ensure proper ventilation when working in trenches, hollows or other confined locations. **This reduces the risk of serious or fatal injury from breathing toxic fumes.**

To reduce the risk of accidents, stop work immediately in the event of nausea, headache, visual disturbances (e.g. reduced field of vision), problems with hearing, dizziness, deterioration in ability to concentrate. Apart from other possibilities, these symptoms may be caused by an excessively high concentration of exhaust gases in the work area.

Operate your power tool so that it produces a minimum of noise and emissions – do not run the engine unnecessarily, accelerate the engine only when working.

The dusts (e.g. sawdust), vapor and smoke produced during operation may be dangerous to health. If dust levels are very high, wear a suitable respirator.

To reduce the risk of fire, do not smoke while operating or standing near your power tool. Note that combustible fuel vapor may escape from the fuel system.

If your power tool is subjected to unusually high loads for which it was not designed (e.g. heavy impact or a fall), always check that it is in good condition before continuing work – see also "Before Starting". Check the fuel system in particular for leaks and make sure the safety devices are working properly. Do not continue operating your power tool if it is damaged. In case of doubt, consult your servicing dealer.

Do not operate your power tool in the starting throttle position – engine speed cannot be controlled in this position.

To reduce the risk of injury, do not touch the auger or drilling spindle unless the engine is stopped and the auger is at a standstill.



Avoid contact with electrical cables or wires – **risk of electric shock**.

Hold the machine firmly in order to control sudden jolts and reactive forces – keep feed pressure relatively low.



Work particularly carefully in rocky ground or ground with a heavy root structure.

Cover and clearly mark boreholes.

To reduce the risk of injury, shut off the engine and engage the auger brake before changing the auger.

To avoid serious burn injuries, avoid touching hot parts of the machine, especially the muffler.

Before leaving the power tool unattended: Shut off the engine.

Check condition of augers regularly. Replace damaged or dull augers immediately.

Vibrations

Prolonged use of the power tool may result in vibration-induced circulation problems in the hands (whitefinger disease).

No general recommendation can be given for the length of usage because it depends on several factors.

The period of usage is prolonged by:

- Hand protection (wearing warm gloves)
- Work breaks

The period of usage is shortened by:

- Any personal tendency to suffer from poor circulation (symptoms: frequently cold fingers, tingling sensations).
- Low outside temperatures.
- The force with which the handles are held (a tight grip restricts circulation).

Continual and regular users should monitor closely the condition of their hands and fingers. If any of the above symptoms appear (e.g. tingling sensation in fingers), seek medical advice.

Maintenance and Repairs

Service the machine regularly. Do not attempt any maintenance or repair work not described in the instruction manual. Have all other work performed by a servicing dealer.

STIHL recommends that you have servicing and repair work carried out exclusively by an authorized STIHL servicing dealer. STIHL dealers are regularly given the opportunity to attend training courses and are supplied with the necessary technical information.

Only use high-quality replacement parts in order to avoid the risk of accidents and damage to the machine. If you have any questions in this respect, consult a servicing dealer.

STIHL recommends the use of genuine STIHL replacement parts. They are specifically designed to match your model and meet your performance requirements.

To reduce the risk of injury, **always shut off the engine** before carrying out any maintenance or repairs or cleaning the machine. – Exception: Carburetor and idle speed adjustments.

Do not turn the engine over on the starter with the spark plug boot or spark plug removed unless the slide control / stop switch is on **STOP** or **0** since there is otherwise a **risk of fire** from uncontained sparking.

To reduce the **risk of fire**, do not service or store your machine near open flames.

Check the fuel filler cap for leaks at regular intervals.

Use only a spark plug of the type approved by STIHL and make sure it is in good condition – see "Specifications".

Inspect the ignition lead (insulation in good condition, secure connection).

Check the condition of the muffler.

To reduce the **risk of fire and damage to hearing**, do not operate your machine if the muffler is damaged or missing.

Do not touch a hot muffler since **burn injury** will result.

Vibration behavior is influenced by the condition of the AV elements – check the AV elements at regular intervals.

Assembling the Unit

Fitting activating lever for auger brake

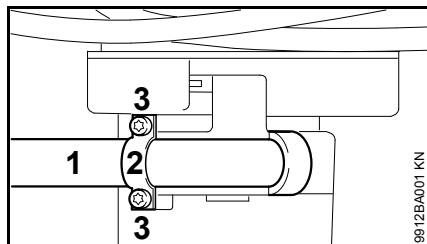

- Insert the activating lever (1) into the clamp
- Place the holder (2) onto the activating lever
- Screw in the fastening screws (3) and tighten

Fit the padding

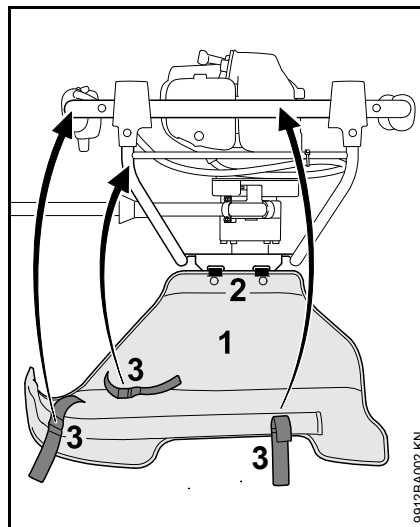

- Hook the padding (1) with the tabs (2) into the oblong holes in the handle frame
- Fold up the padding

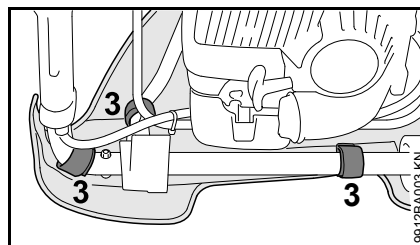

- Secure the padding to the handlebar with the cling strips (3) – do not jam the throttle cable

Adjusting the Throttle Cable

The correct throttle cable setting is a prerequisite for the correct operation of the warm start, idling and full throttle.

Only set the throttle cable when the machine is fully installed – the control handle must be in the working position.

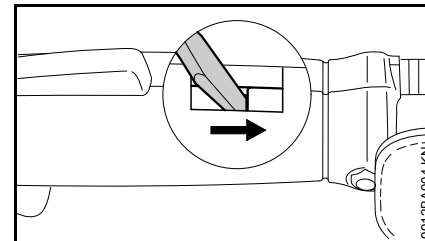

- Use a tool to press the detent on the control handle onto the end of the groove

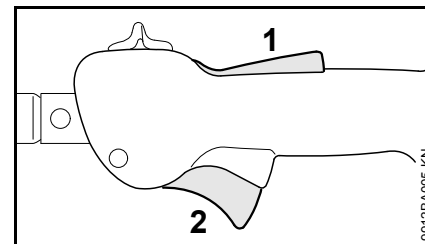

- Open the throttle trigger lockout (1) and throttle trigger (2) wide (full throttle setting) – this sets the throttle cable properly

4-MIX Engine

The **STIHL 4-MIX engine** features mixture lubrication and must be run on a **fuel mixture** of gasoline and engine oil.

It operates otherwise on the 4-stroke principle.

Fuel

Your engine requires a mixture of gasoline and engine oil.



For health reasons, avoid direct skin contact with gasoline and avoid inhaling gasoline vapor.

STIHL MotoMix

STIHL recommends the use of STIHL MotoMix. This ready-to-use fuel mix contains no benzol or lead, has a high octane rating and ensures that you always use the right mix ratio.

STIHL MotoMix uses STIHL HP Ultra two-stroke engine oil for an extra long engine life.

MotoMix is not available in all markets.

Mixing Fuel



Unsuitable fuels or lubricants or mix ratios other than those specified may result in serious damage to the engine.

Poor quality gasoline or engine oil may damage the engine, sealing rings, hoses and the fuel tank.

Gasoline

Use only high-quality **brand-name** gasoline with a minimum octane rating of 90 – leaded or unleaded.

If your machine is equipped with a catalytic converter, you must use unleaded gasoline.



A few tankfuls of leaded gasoline will greatly reduce the efficiency of the catalytic converter.

Gasoline with an ethanol content of more than 10% can cause running problems in engines with a manually adjustable carburetor and should not be used in such engines.

Engines equipped with M-Tronic deliver full power when run on gasoline with an ethanol content of up to 25% (E25).

Engine oil

Use only high-quality two-stroke engine oil – preferably **STIHL HP, HP Super or HP Ultra, which are specially formulated for use in STIHL engines. HP Ultra guarantees high performance and a long engine life.**

These engine oils are not available in all markets.

Use only **STIHL 50:1 two-stroke engine oil** for the fuel mix in models with a catalytic converter.

Mix Ratio

STIHL 50:1 two-stroke engine oil: 50 parts gasoline to 1 part oil

Examples

Gasoline Liters	STIHL engine oil 50:1 Liters (ml)
1	0.02 (20)
5	0.10 (100)
10	0.20 (200)
15	0.30 (300)
20	0.40 (400)
25	0.50 (500)

- Use a canister approved for storing fuel. Pour oil into canister first, then add gasoline and mix thoroughly.

Storing Fuel

Store fuel only in approved safety-type fuel canisters in a dry, cool and safe location protected from light and the sun.

Fuel mix ages – only mix sufficient fuel for a few weeks work. Do not store fuel mix for longer than 30 days. Exposure to light, the sun, low or high temperatures can quickly make the fuel mix unusable.

STIHL MotoMix may be stored for up to 2 years without any problems.

- Thoroughly shake the mixture in the canister before fueling your machine.

WARNING

Pressure may build up in the canister – open it carefully.

- Clean the fuel tank and canister from time to time.

Dispose of remaining fuel and cleaning fluid properly in accordance with local regulations and environmental requirements.

Fueling



Preparing the machine

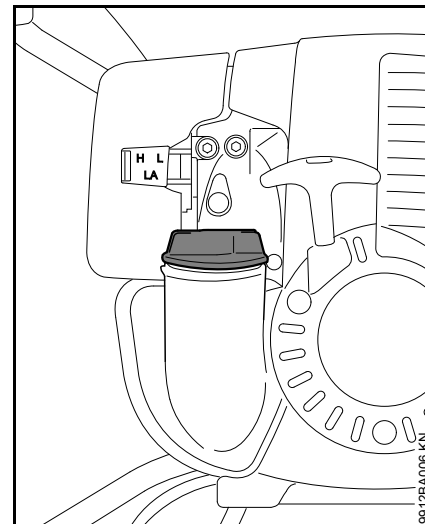

- Before fueling, clean the filler cap and the area around it so that dirt cannot fall into the tank
- Always position the machine so that the filler cap is facing upwards

Refuelling

Take care not to spill fuel while fueling and do not overfill the tank. STIHL recommends use of the STIHL filling system for fuel (special accessory).

- Opening the twist lock
- Refuelling
- Closing the filler cap

WARNING

After fueling, tighten down the filler cap by hand as securely as possible.

Auger Brake

Activating the auger brake

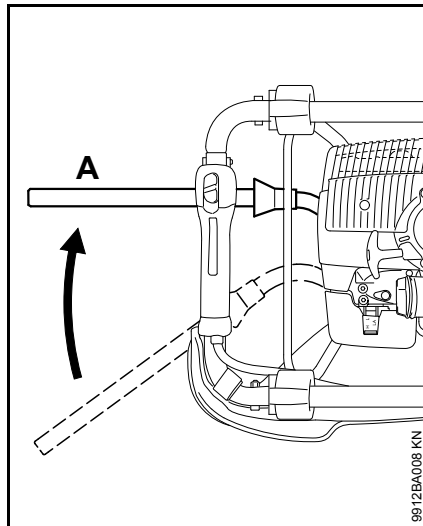

- Set the activating lever to A
 - when starting
 - when idling
 - to unscrew a secured auger

If the auger catches in the drilled hole (e. g. on roots or stones), the auger moves counterclockwise – the activating lever is pushed against the thigh of the operator and the auger brake is triggered.

Releasing the auger brake

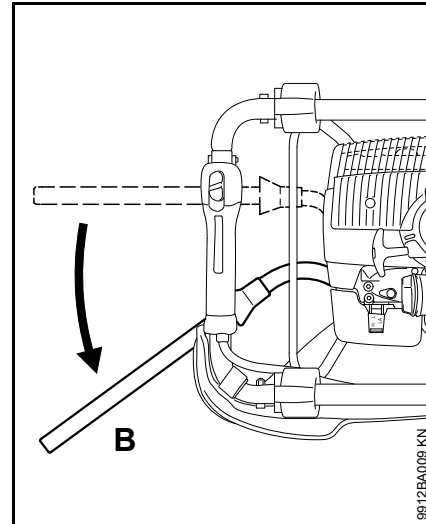

- Set the activating lever to B

Checking the auger brake for proper functioning

The auger brake is subject to normal wear. Before starting work and after releasing a jammed auger, check regularly if it is fulfilling its function.

Each time before starting work and after releasing a jammed auger

- When idling, activate the auger brake and open the throttle wide for a brief period (max. 3 seconds) – the auger must not rotate.

If the auger brake fails, it must be repaired immediately by a servicing dealer – STIHL recommends the STIHL dealer.

Fitting the Auger

- Switch off the motor and activate the auger brake – see "Auger brake"
- Put down the auger – drilling spindle facing upwards

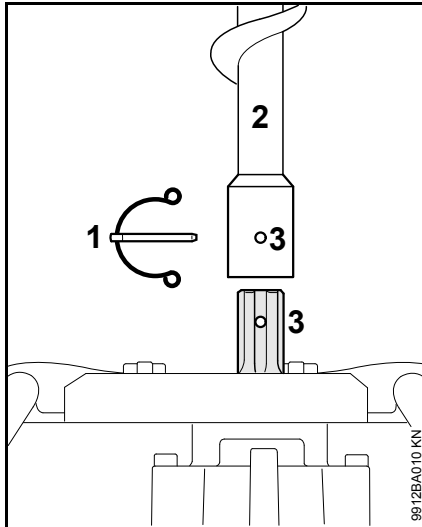

- Pull the retaining pin (1) out of the auger shaft
- Push the auger (2) onto the drilling spindle until the holes (3) align
- Insert the retaining pin into the hole
- Fold down the spring clip of the retaining pin so that it encloses the auger shaft

Starting / Stopping the Engine

Engaging the Auger Brake

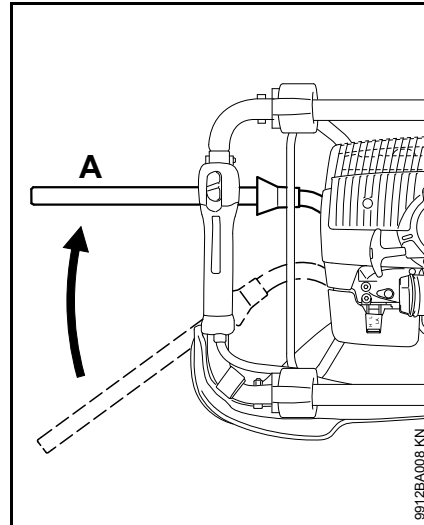

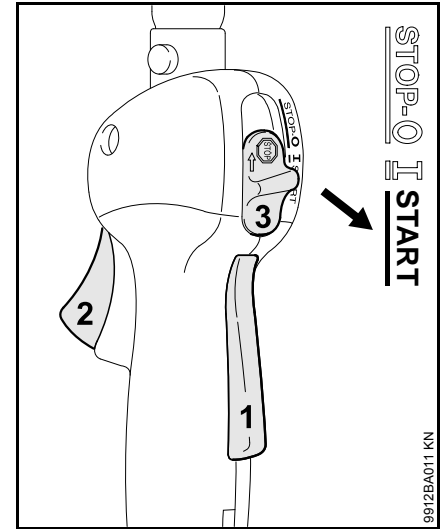

- Move the activating lever to position **A** .

Starting

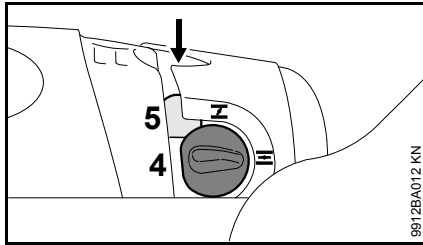

- Press down the trigger lockout lever (1), then squeeze the throttle trigger (2)
- and hold them in that position.
- Move the slide control (3) to **START** and hold it there.
- Now release the throttle trigger, slide control and trigger lockout in that order. This is the **starting throttle position**.



- Set the choke knob (4) to:
 -  if the engine is cold
 -  for warm start – also use this position if the engine has been running but is still cold.
- Press the manual fuel pump bulb (5) at least five times.

Cranking

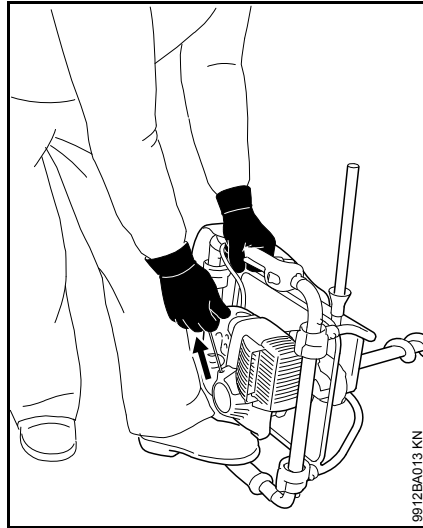

- Place the unit on the ground so that it is secure.
- Put your left foot on the handle frame.
- Left hand on the handle frame.
- Pull the starter grip slowly with your right hand until you feel it engage and then give it a brisk strong pull.

NOTICE

Do not pull out the starter rope all the way – it **might otherwise break**.

- Do not let the starter grip snap back. Guide it slowly back into the housing so that the starter rope can rewind properly.
- Continue cranking.

When engine begins to fire

- Set the choke knob to  and
- continue cranking until the engine runs.

As soon as the engine runs

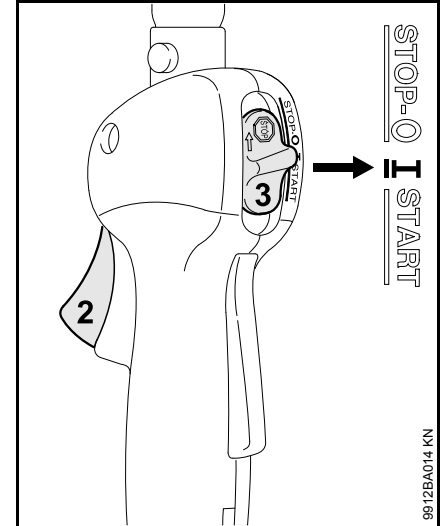

- Blip the throttle trigger (2) – the slide control (3) moves to the run position I and the engine settles down to idling speed.

NOTICE

Since the auger brake is still engaged, the engine must be returned to idling speed **immediately** – or the clutch might otherwise be damaged.

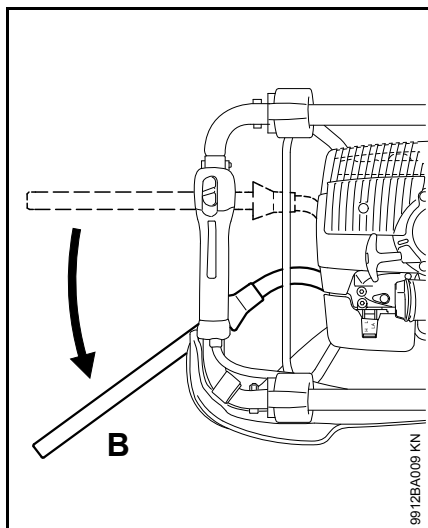

- Stand the unit on the tip of the auger.
- Disengage the auger brake by moving the activating lever to position **B**. Your earth auger is now ready for operation.

Make sure the carburetor is correctly adjusted. The auger must not rotate when the engine is idling.

Stopping the Engine

- Move the slide control to **STOP-0**.

At very low outside temperatures

- When the engine starts, blip the throttle trigger to disengage the **starting throttle position** – the slide control moves to the run position **I** and the engine settles down to idling speed.
- Open the throttle slightly.
- Warm up the engine for a short period.

If engine does not start

If you did not move the choke knob quickly enough to $\overline{\text{I}}$ after the engine began to fire, the engine is flooded.

- Set the choke knob to $\overline{\text{I}}$ and
- Set the slide control, trigger lockout and throttle trigger to the starting throttle position.
- Start the engine by pulling the starter rope briskly – 10 to 20 pulls may be necessary.

If the engine still does not start

- Move the slide control to **STOP-0**.
- Remove the spark plug – see "Spark Plug".
- Dry the spark plug.
- Crank the engine several times with the starter to clear the combustion chamber.

- Refit the spark plug – see "Spark Plug".
- Move the slide control to **START**.
- Set the choke knob to $\overline{\text{I}}$ – even if the engine is cold.
- Now start the engine.

Throttle cable adjustment

- Check adjustment of throttle cable – see chapter on "Adjusting the Throttle Cable".

If fuel tank has been run completely dry and then refueled

- After refueling, press the manual fuel pump bulb at least five times – even if the bulb is filled with fuel.
- Set the choke knob according to engine temperature.
- Now start the engine.

Operating Instructions

During break-in period

A factory-new machine should not be run at high revs (full throttle off load) for the first three tank fillings. This avoids unnecessary high loads during the break-in period. As all moving parts have to bed in during the break-in period, the frictional resistances in the engine are greater during this period. The engine develops its maximum power after about 5 to 15 tank fillings.

During Operation

After a long period of full throttle operation, allow the engine to run for a short while at idle speed so that engine heat can be dissipated by the flow of cooling air. This protects engine-mounted components (ignition, carburetor) from thermal overload.

After Finishing Work

Storing for a short period: Wait for the engine to cool down. To avoid condensation, fill the fuel tank and keep the machine in a dry place, well away from sources of ignition, until you need it again. For longer out-of-service periods – see "Storing the Machine".

Working with shaft extension (special accessory)

Do not fit the shaft extension until the full length of the auger is in the hole.

! WARNING

Starting a hole with the shaft extension fitted increases the risk of personal injury because the unit is then at chest height and cannot be controlled properly. For the same reason the shaft extension must be removed before the auger is pulled out of the hole.

Inspection by a specialist

If the machine is used commercially, it must be inspected at least once a year by a specialist.

Specialists are persons with the technical training and experience necessary to assess the safe working condition of the earth auger.

Releasing a Trapped Auger

If the auger is jammed in the drilling hole

- Switch off the engine immediately
- Set the slide control to **STOP-0**

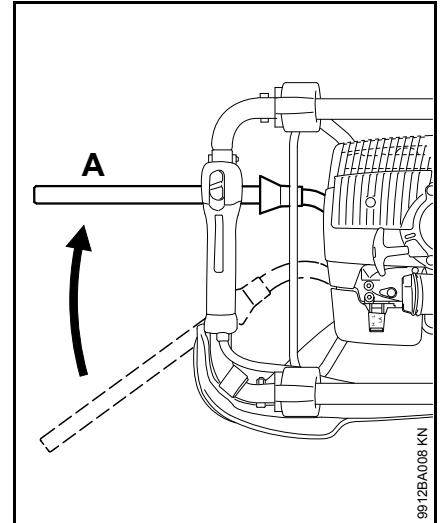

- Set the activating lever to **A** – the auger brake is activated
- Turn the whole auger counterclockwise to the left until the auger is released again
- Once the jammed auger is released, check that the auger brake functions properly – see "Auger brake"

Replacing the Air Filter

If there is a noticeable loss of engine power

- Remove the padding on the handle frame

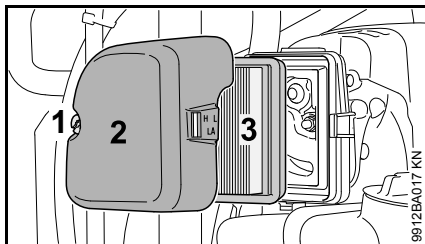

- Unscrew the screw (1) and remove the filter cover (2) – screw is fastened in the filter cover so that it is secured against loss
- Remove coarse dirt from inside the filter cover (2) and around the air filter (3)
- Remove and examine the air filter (3) – replace if soiled or damaged
- Fit the air filter (3)
- Fit the filter cover (2)
- Screw in the screw (1) and tighten
- Fit the padding – see “Assembling the machine”

Adjusting the Carburetor

The carburetor of the machine has been adjusted for optimum performance and fuel efficiency in all operating states at the factory.

Setting the idle speed

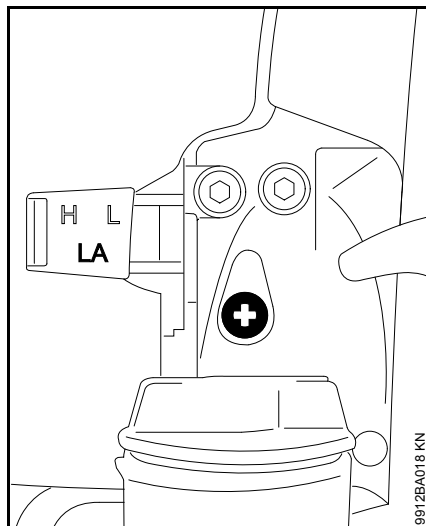

Engine stops when idling

- Turn the idle speed adjusting screw (LA) slowly clockwise until the engine runs smoothly.

Auger turns when idling

- Turn the idle speed adjusting screw (LA) slowly counterclockwise until the auger stops turning

! WARNING

If the auger continues to keep moving in idle even after adjustment, have the machine checked by a servicing dealer.

Spark Plug

- If the engine is down on power, difficult to start or runs poorly at idle speed, first check the spark plug.
- Fit a new spark plug after about 100 operating hours – or sooner if the electrodes are badly eroded. Install only suppressed spark plugs of the type approved by STIHL – see "Specifications".

Removing the spark plug

- Set the slide control to **STOP-0**

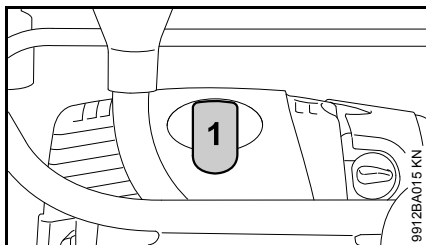

- Unplug spark plug boot (1)
- Unscrew spark plug

Checking the spark plug

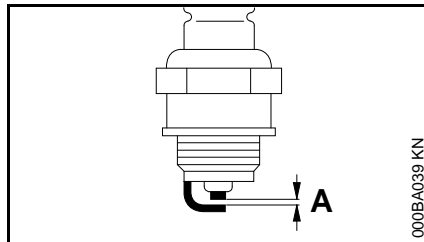

- Clean dirty spark plug.
- Check electrode gap (A) and readjust if necessary – see "Specifications".
- Rectify the problems which have caused fouling of the spark plug.

Possible causes are:

- Too much oil in fuel mix.
- Dirty air filter.
- Unfavorable running conditions.

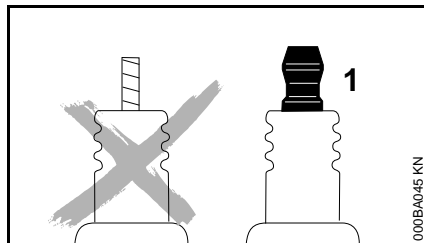

WARNING

If the spark plug comes with a detachable adapter nut (1), screw the adapter onto the thread and tighten it down **firmly** to reduce the **risk of arcing and fire**.

Installing the spark plug

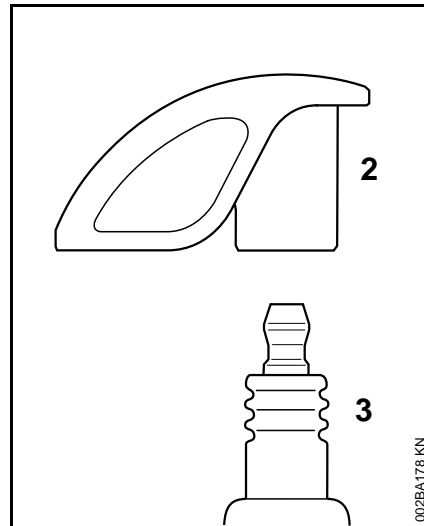

- Screw the spark plug (3) into the cylinder and fit the boot (2) (press it down firmly).

Engine Running Behavior

If engine running behavior is still unsatisfactory after the air filter has been serviced and the carburetor and throttle cable have been adjusted correctly, the cause may also be in the muffler.

Have the muffler checked for contamination (coking) by a servicing dealer!

STIHL recommends that maintenance and repair work be carried out only by authorized STIHL dealers.

Lubricating the Gearbox

- Check the lubricant filling periodically – approx. every 50 hours of operation

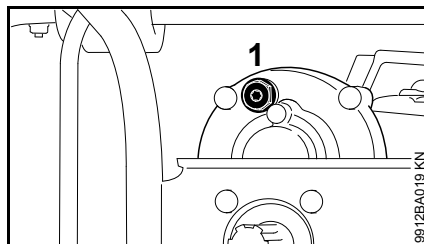

- Remove the screw plug (1)

If no grease can be seen on the inside of the screw plug:

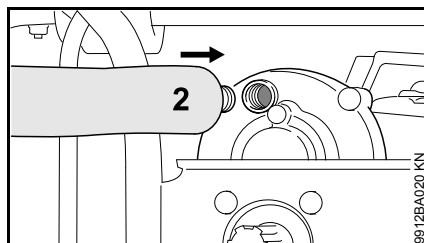

- Apply tube (2) of gear lubricant
- Squeeze grease into the gear housing – approx. 5 to 10 g
- Do not completely fill the gear housing with grease
- Refit locking screw and tighten securely

Rewind Starter

To help prolong the wear life of the starter rope, observe the following points:

- Pull the starter rope only in the direction specified.
- Do not pull the rope over the edge of the guide bushing.
- Do not pull out the rope more than specified.
- Do not allow the starter grip to snap back, guide it back into the housing slowly – see chapter on "Starting / Stopping the Engine."

Have a damaged starter rope replaced by your dealer before it breaks completely. STIHL recommends that you have servicing and repair work carried out exclusively by an authorized STIHL servicing dealer.

Storing the Machine

For periods of 3 months or longer

- Remove the drilling tool.
- Drain and clean the fuel tank in a well ventilated area.
- Dispose of fuel properly in accordance with local environmental requirements.
- Run the engine until the carburetor is dry – this helps prevent the carburetor diaphragms sticking together.
- Thoroughly clean the machine – pay special attention to the cylinder fins and air filter.
- Store the machine in a dry, high or locked location, out of the reach of children and other unauthorized persons.

Inspections and Maintenance by Dealer

Maintenance work

STIHL recommends that maintenance and repair work be carried out only by authorized STIHL dealers.

Fuel pickup body in tank

- Have the fuel pickup body in the fuel tank changed once every year

Spark arrestor in muffler

- If engine performance deteriorates, have the spark arresting screen in the muffler checked

Maintenance and Care

The following intervals apply to normal operating conditions only. If your daily working time is longer or operating conditions are difficult (very dusty work area, etc.), shorten the specified intervals accordingly.		before starting work	after finishing work or daily	after each refueling stop	weekly	monthly	every 12 months	if problem	if damaged	as required
Complete machine	Visual inspection (condition, leaks)	X		X						
	Clean		X							
Auger brake	Check operation	X		X						
	Have serviced by dealer ¹⁾									X
Control handle	Check operation	X		X						
Air filter	Replace								X	X
Manual fuel pump (if fitted)	Check	X								
	Have repaired by servicing dealer ¹⁾								X	
Pickup body in fuel tank	Have checked by servicing dealer ¹⁾							X		
	Have replaced by servicing dealer ¹⁾						X			X
Fuel tank	Clean					X				
Carburetor	Check idle adjustment – drilling spindle must not rotate	X								
	Readjust idle									X
Spark plug	Readjust electrode gap							X		
	Replace after every 100 operating hours									
Spark arrestor in muffler	Have checked by servicing dealer ¹⁾							X		
	Have cleaned or replaced by servicing dealer ¹⁾								X	X
All accessible screws and nuts (not adjusting screws)	Retighten									X
Anti-vibration elements	Check	X						X		X
	Have replaced by servicing dealer ¹⁾								X	
Gearbox	Re-lubricate									X

The following intervals apply to normal operating conditions only. If your daily working time is longer or operating conditions are difficult (very dusty work area, etc.), shorten the specified intervals accordingly.		before starting work	after finishing work or daily	after each refueling stop	weekly	monthly	every 12 months	if problem	if damaged	as required
Drilling spindle	Clean		X							
Auger	Check	X								
	Replace									X
Safety labels	Replace								X	

1) STIHL recommends an authorized STIHL servicing dealer.

Minimize Wear and Avoid Damage

Observing the instructions in this manual helps reduce the risk of unnecessary wear and damage to the power tool.

The power tool must be operated, maintained and stored with the due care and attention described in this owner's manual.

The user is responsible for all damage caused by non-observance of the safety precautions, operating and maintenance instructions in this manual. This includes in particular:

- Alterations or modifications to the product not approved by STIHL.
- Using tools or accessories which are neither approved or suitable for the product or are of a poor quality.
- Using the product for purposes for which it was not designed.
- Using the product for sports or competitive events.
- Consequential damage caused by continuing to use the product with defective components.

Maintenance Work

All the operations described in the "Maintenance Chart" must be performed on a regular basis. If these maintenance operations cannot be performed by the owner, they should be performed by a servicing dealer.

STIHL recommends that you have servicing and repair work carried out exclusively by an authorized STIHL servicing dealer. STIHL dealers are regularly given the opportunity to attend training courses and are supplied with the necessary technical information.

If these maintenance operations are not carried out as specified, the user assumes responsibility for any damage that may occur. Among other parts, this includes:

- Damage to the engine due to neglect or deficient maintenance (e.g. air and fuel filters), incorrect carburetor adjustment or inadequate cleaning of cooling air inlets (intake ports, cylinder fins).
- Corrosion and other consequential damage resulting from improper storage.
- Damage to the machine resulting from the use of poor quality replacement parts.

Parts Subject to Wear and Tear

Some parts of the power tool are subject to normal wear and tear even during regular operation in accordance with instructions and, depending on the type and duration of use, have to be replaced in good time. Among other parts, this includes:

- Clutch
- Augers
- Filters (air, fuel)
- Rewind starter
- Spark plug
- Damping elements of anti-vibration system

Main Parts

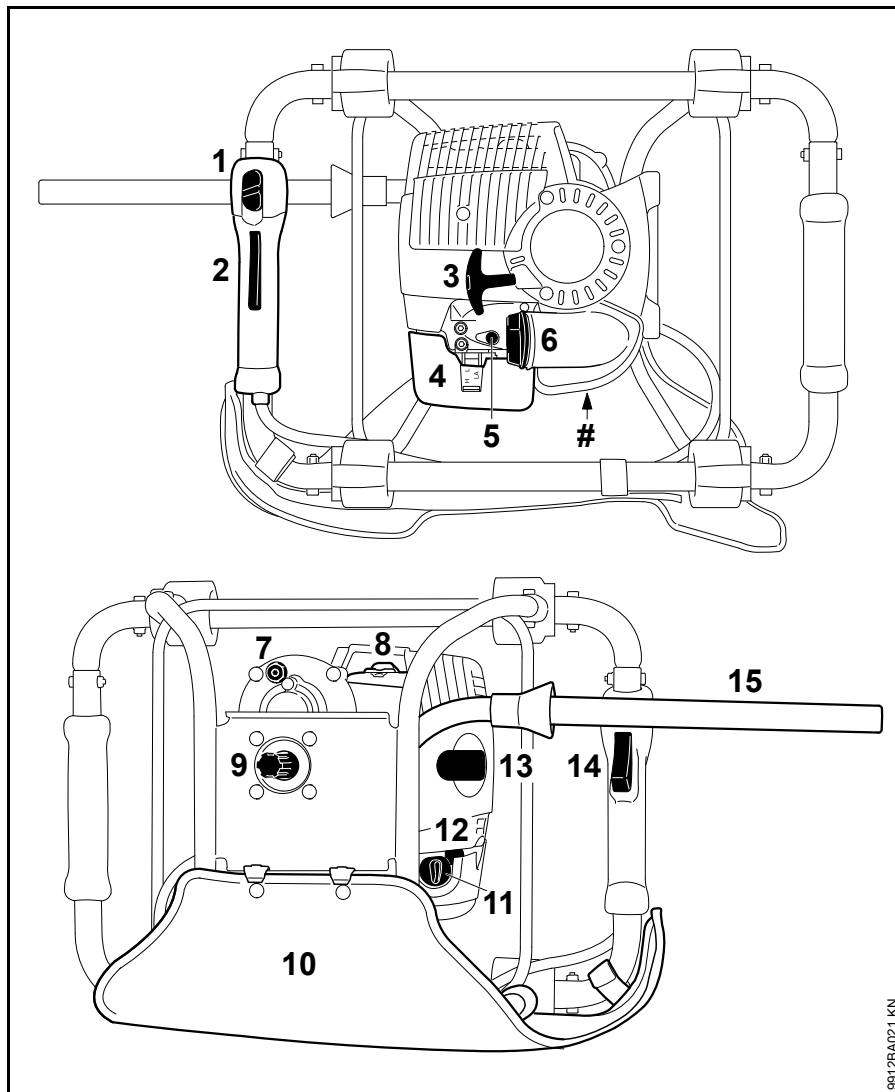

- 1 Slide control
- 2 Throttle trigger lockout
- 3 Starter grip
- 4 Filter cover
- 5 Carburetor adjusting screws
- 6 Tank cap
- 7 Screw plug
- 8 Muffler with spark arresting screen
- 9 Drilling spindle
- 10 Padding
- 11 Choke knob
- 12 Manual fuel pump
- 13 Spark plug boot
- 14 Throttle trigger
- 15 Auger brake lever
- # Serial number

Specifications

Engine

STIHL single cylinder four-stroke engine with mixture lubrication

Displacement:	36.3 cc
Bore:	43 mm
Stroke:	25 mm
Engine power to ISO 7293:	1.4 kW (1.9 bhp) at 8,500 rpm
Idle speed:	2,800 rpm
Cut-off speed:	9,500 rpm
Valve clearance, inlet:	0.10 mm
Valve clearance, exhaust:	0.10 mm

Ignition System

Electronic (breakerless) magneto ignition

Spark plug (resistor type):	NGK CMR 6H
Electrode gap:	0.5 mm

Fuel System

All position diaphragm carburetor with integral fuel pump

Fuel tank capacity:	530 cc (0.53 l)
---------------------	-----------------

Drilling gear

Two-stage spur gear drive

Gear ratio:	47.5:1
Max. spindle speed:	200 rpm
Max. torque at drilling spindle:	81 Nm
Lubrication:	STIHL gear lubricant for brushcutters

Weight

Dry, without drilling tool (auger):	9.9 kg
-------------------------------------	--------

Dimensions

Length with handle frame:	400 mm
Width with handle frame:	530 mm
Height without drilling tool (auger):	365 mm

Sound and vibration levels

When determining sound and vibration levels, idling and the nominal maximum engine speed are taken into account in a ratio of 1:4.

For further details concerning compliance with the Physical Agents Directive Vibration 2002/44/EC, see www.stihl.com/vib

Sound pressure level L_{peq} to ISO 11201

92 dB(A)

Sound power level L_{weq} to ISO 3744

100 dB(A)

Vibration level $a_{hv,eq}$ to ISO 20643

Earth auger 90 mm

Left handle:	1.5 m/s ²
Right handle:	2.2 m/s ²

The K-factor in accordance with Directive 2006/42/EC is 2.5 dB(A) for the sound pressure level and sound power level; the K-factor in accordance with Directive 2006/42/EC is 2.0 m/s² for the vibration measurement.

REACH

REACH is an EC regulation and stands for the Registration, Evaluation, Authorisation and Restriction of Chemical substances.

For information on compliance with the REACH regulation (EC) No. 1907/2006 see www.stihl.com/reach.

Special Accessories

Earth augers

Diameter: 40, 60, 90, 120,
150, 200 mm

Length: 695 mm

Planting auger

Diameter: 150 mm

Length: 525 mm

Planting hole auger

Diameter: 260 mm

Length: 660 mm

Other special accessories

Shaft extension: 250, 450 mm

Chuck for spiral drills: Diameters up to
13 mm

Contact your STIHL dealer for more information on these and other special accessories.

Maintenance and Repairs

Users of this machine may only carry out the maintenance and service work described in this user manual. All other repairs must be carried out by a servicing dealer.

STIHL recommends that you have servicing and repair work carried out exclusively by an authorized STIHL servicing dealer. STIHL dealers are regularly given the opportunity to attend training courses and are supplied with the necessary technical information.

When repairing the machine, only use replacement parts which have been approved by STIHL for this power tool or are technically identical. Only use high-quality replacement parts in order to avoid the risk of accidents and damage to the machine.

STIHL recommends the use of original STIHL replacement parts.

Original STIHL parts can be identified by the STIHL part number, the **STIHL** logo and the STIHL parts symbol  (the symbol may appear alone on small parts).

Disposal

Observe all country-specific waste disposal rules and regulations.

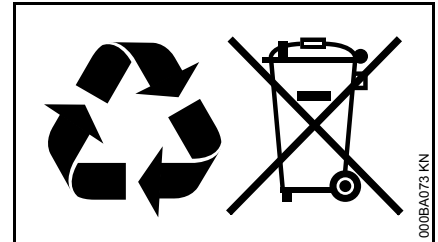

STIHL products must not be thrown in the garbage can. Take the product, accessories and packaging to an approved disposal site for environment-friendly recycling.

Contact your STIHL servicing dealer for the latest information on waste disposal.

EC Declaration of Conformity

ANDREAS STIHL AG & Co. KG
Badstr. 115
D-71336 Waiblingen

hereby confirms that

Model: Earth Auger
Make: STIHL
Type: BT 130

Serial identification
number: 4313

Displacement: 36.3 cm³

conform to the specifications of
Directives 2006/42/EC and
2004/108/EC and have been developed
and built in compliance with the following
standards:

EN ISO 12100, EN 55012,
EN 61000-6-1

The technical documentation has been
retained by:

ANDREAS STIHL AG & Co. KG
Product approval

The year of construction and the serial
number are shown on the machine.

Waiblingen, 01.07.2013

ANDREAS STIHL AG & Co. KG

p p.



Thomas Elsner

Head of Product Group Management



0458-429-0121-A

englisch



www.stihl.com



0458-429-0121-A