



# Bobcat®

---

## Operation & Maintenance Manual S70 Skid-Steer Loader

---

S/N A3W611001 & Above  
S/N A3W711001 & Above  
S/N B38V11001 & Above

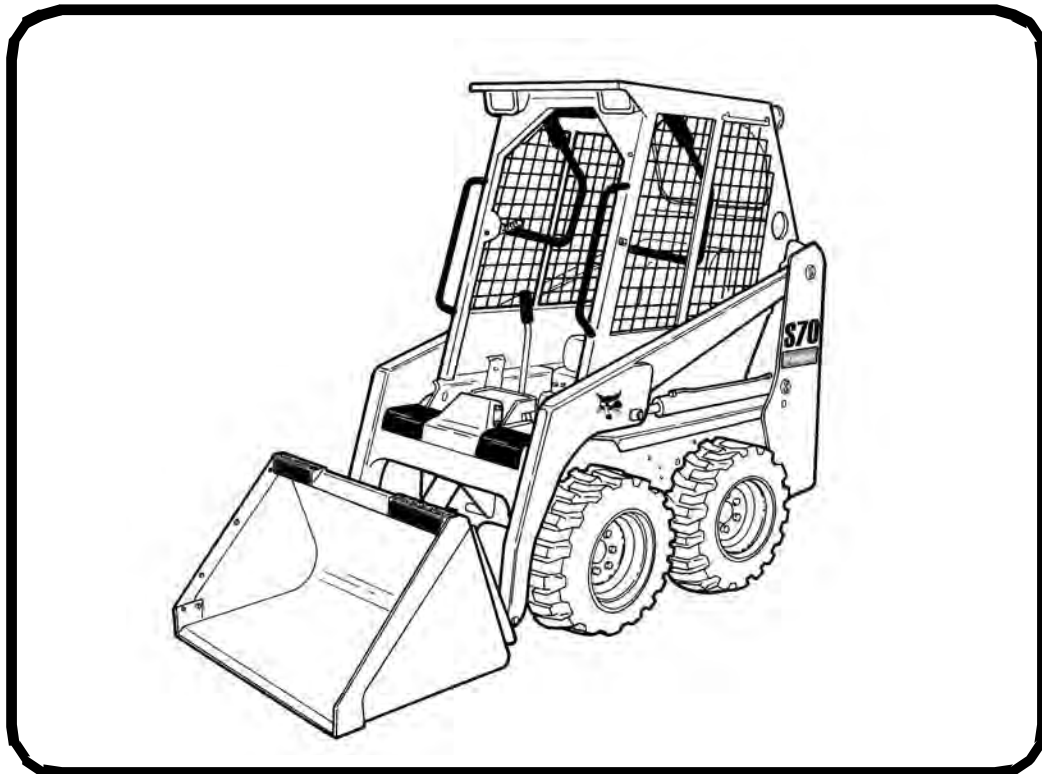

EQUIPPED WITH  
BOBCAT INTERLOCK  
CONTROL SYSTEM (BICS™)





# OPERATOR SAFETY WARNINGS



## WARNING

Operator must have instructions before operating the machine. Untrained operators can cause injury or death.

W-2001-0502



**Safety Alert Symbol:** This symbol with a warning statement, means: "Warning, be alert! Your safety is involved!" Carefully read the message that follows.

CORRECT

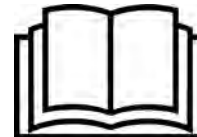

P-90216

⚠ Never use the loader without instructions. See machine signs (decals), Operation & Maintenance Manual, and Operator's Handbook.

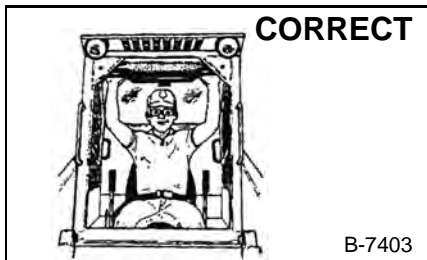

CORRECT

B-7403

⚠ Always use the seat bar and fasten seat belt snugly.  
⚠ Always keep feet on the foot pedals or footrests when operating loader.

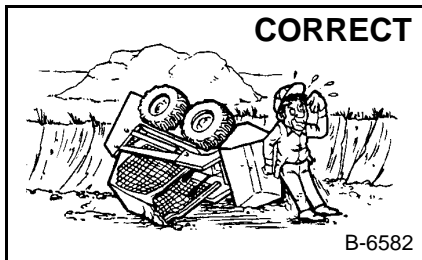

CORRECT

B-6582

⚠ Never use loader without operator cab with ROPS and FOPS approval. Fasten your seat belt.

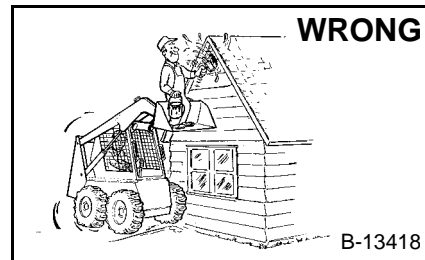

WRONG

B-13418

⚠ Never use loader as man lift or elevating device for personnel.

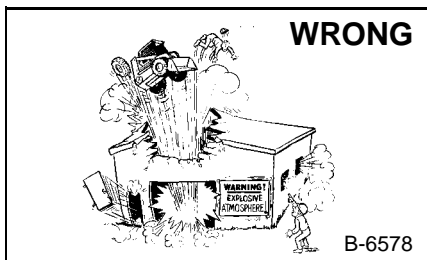

WRONG

B-6578

⚠ Do not use loader in atmosphere with explosive dust, explosive gas, or where exhaust can contact flammable material.

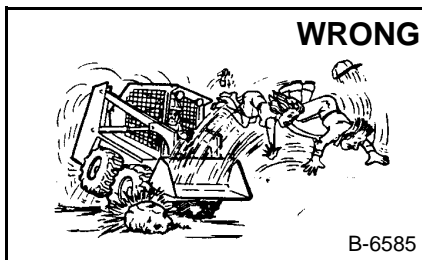

WRONG

B-6585

⚠ Never carry riders.  
⚠ Keep bystanders away from work area.

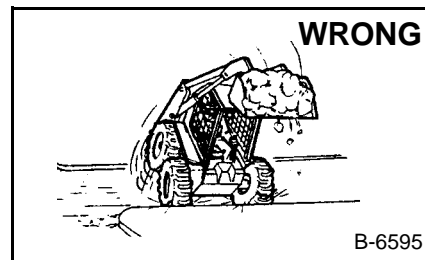

WRONG

B-6595

⚠ Always carry bucket or attachments as low as possible.  
⚠ Do not travel or turn with lift arms up.  
⚠ Load, unload, and turn on flat level ground.

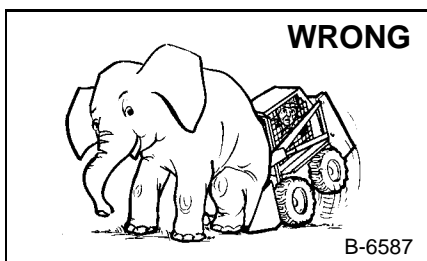

WRONG

B-6587

⚠ Never exceed Rated Operating Capacity.

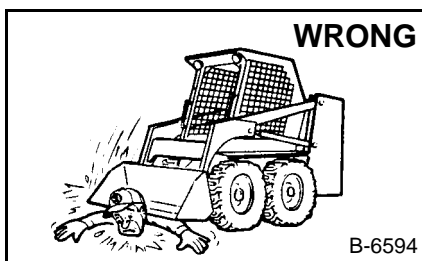

WRONG

B-6594

⚠ Never leave loader with engine running or with lift arms up.  
⚠ To park, engage parking brake and put attachment flat on the ground.

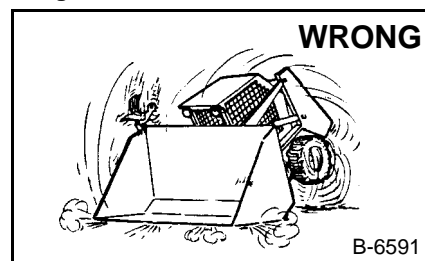

WRONG

B-6591

⚠ Never modify equipment.  
⚠ Use only attachments approved by Bobcat Company for this model loader.

## SAFETY EQUIPMENT

The Bobcat Loader must be equipped with safety items necessary for each job. Ask your dealer for information on the safe use of attachments and accessories.

1. SEAT BELT: Check belt fasteners and check for damaged webbing or buckle.
2. SEAT BAR: When up, it must lock the loader controls.
3. OPERATOR CAB (ROPS and FOPS): It must be on the loader with all fasteners tight.
4. OPERATOR'S HANDBOOK: Must be in the cab.
5. SAFETY SIGNS (DECALS): Replace if damaged.
6. SAFETY TREADS: Replace if damaged.
7. GRAB HANDLES: Replace if damaged.
8. LIFT ARM SUPPORT DEVICE: Replace if damaged.
9. PARKING BRAKE
10. BOBCAT INTERLOCK CONTROL SYSTEM (BICS)

OSW03-0409



**Bobcat®**

# CONTENTS

FOREWORD .....	5
SAFETY AND TRAINING RESOURCES .....	13
OPERATING INSTRUCTIONS .....	23
PREVENTIVE MAINTENANCE .....	65
SYSTEM SETUP AND ANALYSIS .....	109
MACHINE SIGN TRANSLATIONS .....	115
SPECIFICATIONS .....	127
WARRANTY .....	133
ALPHABETICAL INDEX .....	137

## REFERENCE INFORMATION

Write the correct information for YOUR Bobcat loader in the spaces below. Always use these numbers when referring to your Bobcat loader.

Loader Serial Number \_\_\_\_\_  
Engine Serial Number \_\_\_\_\_

NOTES:

\_\_\_\_\_  
\_\_\_\_\_  
\_\_\_\_\_

YOUR BOBCAT DEALER:

ADDRESS:

PHONE:

Bobcat Company  
P.O. Box 128  
Gwinner, ND 58040-0128  
UNITED STATES OF AMERICA

Doosan Benelux SA  
Drève Richelle 167  
B-1410 Waterloo  
BELGIUM



**Bobcat®**

## FOREWORD

This Operation & Maintenance Manual was written to give the owner / operator instructions on the safe operation and maintenance of the Bobcat loader. READ AND UNDERSTAND THIS OPERATION & MAINTENANCE MANUAL BEFORE OPERATING YOUR BOBCAT LOADER. If you have any questions, see your Bobcat dealer. This manual may illustrate options and accessories not installed on your loader.

BOBCAT COMPANY IS ISO 9001 CERTIFIED .....	7
REGULAR MAINTENANCE ITEMS .....	7
SERIAL NUMBER LOCATIONS .....	8
Loader Serial Number .....	8
Engine Serial Number .....	8
DELIVERY REPORT .....	8
LOADER IDENTIFICATION .....	9
FEATURES, ACCESSORIES AND ATTACHMENTS .....	10
Standard Items .....	10
Options And Accessories .....	10
Buckets Available .....	11
Attachments .....	11
Special Applications Kit .....	12
Special Applications Kit Inspection And Maintenance .....	12



**Bobcat®**



**BOBCAT COMPANY IS ISO 9001 CERTIFIED**



ISO 9001 is an international standard that specifies requirements for a quality management system that controls the processes and procedures which we use to design, develop, manufacture and distribute Bobcat products.









British Standards Institute (BSI) is the Certified Registrar Bobcat Company chose to assess the Company's compliance with the ISO 9001 at Bobcat's manufacturing facilities in Gwinner and Bismarck, North Dakota (U.S.A.), Pontchateau (France), Dobris (Czech Republic) and the Bobcat corporate offices (Gwinner, Bismarck & West Fargo) in North Dakota. Only certified assessors, like BSI, can grant registrations.

ISO 9001 means that as a company we say what we do and do what we say. In other words, we have established procedures and policies, and we provide evidence that the procedures and policies are followed.

**CALIFORNIA PROPOSITION 65 WARNING**

Diesel engine exhaust and some of its constituents are known to the State of California to cause cancer, birth defects and other reproductive harm.

**REGULAR MAINTENANCE ITEMS**

	ENGINE OIL FILTER (6 Pack) 6657635		BREATHER CAP 7025626
	FUEL FILTER 6667352		BATTERY 6674687
	AIR FILTER, Outer 6672467		FLUID, Hydraulic / Hydrostatic  6903117 - (2.5 U.S. gal) 6903118 - (5 U.S. gal) 6903119 - (55 U.S. gal)
	AIR FILTER, Inner 6672468		
	HYDROSTATIC FILTER 6677652		ANTI-FREEZE, Propylene Glycol  6983128 - Premixed 6983129 - Concentrate
<b>ENGINE OIL</b> 7023080 SAE 15W40 CE/SG (12 qt) 7023076 SAE 10W30 CE/SG (12 qt) 6903109 SAE 30W CE/SG (12 qt)  7023082 SAE 15W40 CE/SG (2.5 U.S. gal) 7023078 SAE 10W30 CE/SG (2.5 U.S. gal) 6903111 SAE 30W CE/SG (2.5 U.S. gal)		<b>ENGINE OIL</b> 7023081 SAE 15W40 CE/SG (1 U.S. gal) 7023077 SAE 10W30 CE/SG (1 U.S. gal) 6903110 SAE 30W CE/SG (1 U.S. gal)	

**NOTE: Always verify Part Numbers with your Bobcat dealer.**

## SERIAL NUMBER LOCATIONS

Always use the serial number of the loader when requesting service information or when ordering parts. Early or later models (identification made by serial number) may use different parts, or it may be necessary to use a different procedure in doing a specific service operation.

### Loader Serial Number

Figure 1

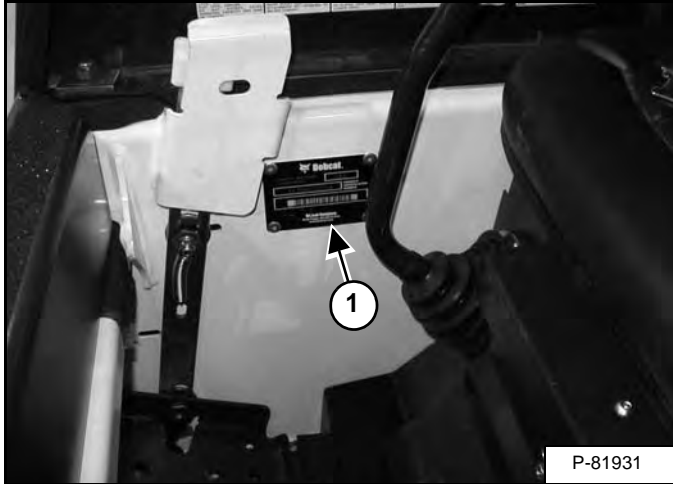

The loader serial number plate (Item 1) [Figure 1] is located inside the cab on the right-hand side.

Figure 2

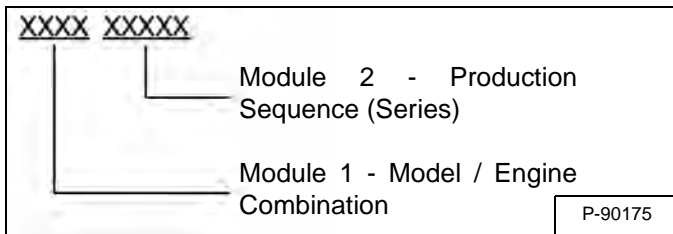

Explanation of loader Serial Number [Figure 2]:

1. The four digit Model / Engine Combination Module number identifies the model number and engine combination.
2. The five digit Production Sequence Number identifies the order which the loader is produced.

### Engine Serial Number

Figure 3

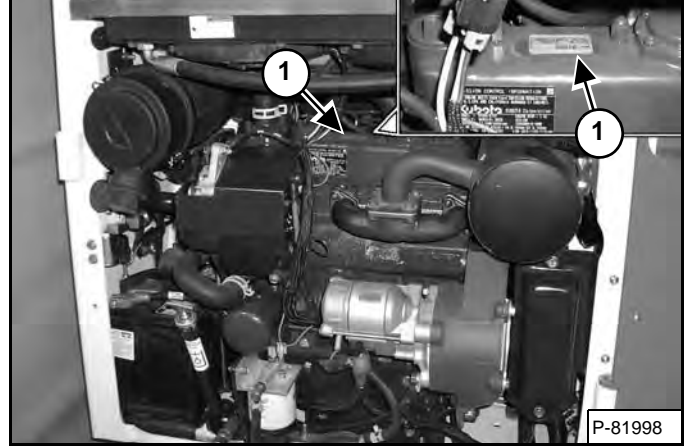

The engine serial number is located on top of the engine (Item 1) [Figure 3].

## DELIVERY REPORT

Figure 4

The delivery report [Figure 4] contains a list of items that must be explained or shown to the owner or operator by the dealer when the Bobcat loader is delivered.

The delivery report must be reviewed and signed by the owner or operator and the dealer.

## LOADER IDENTIFICATION

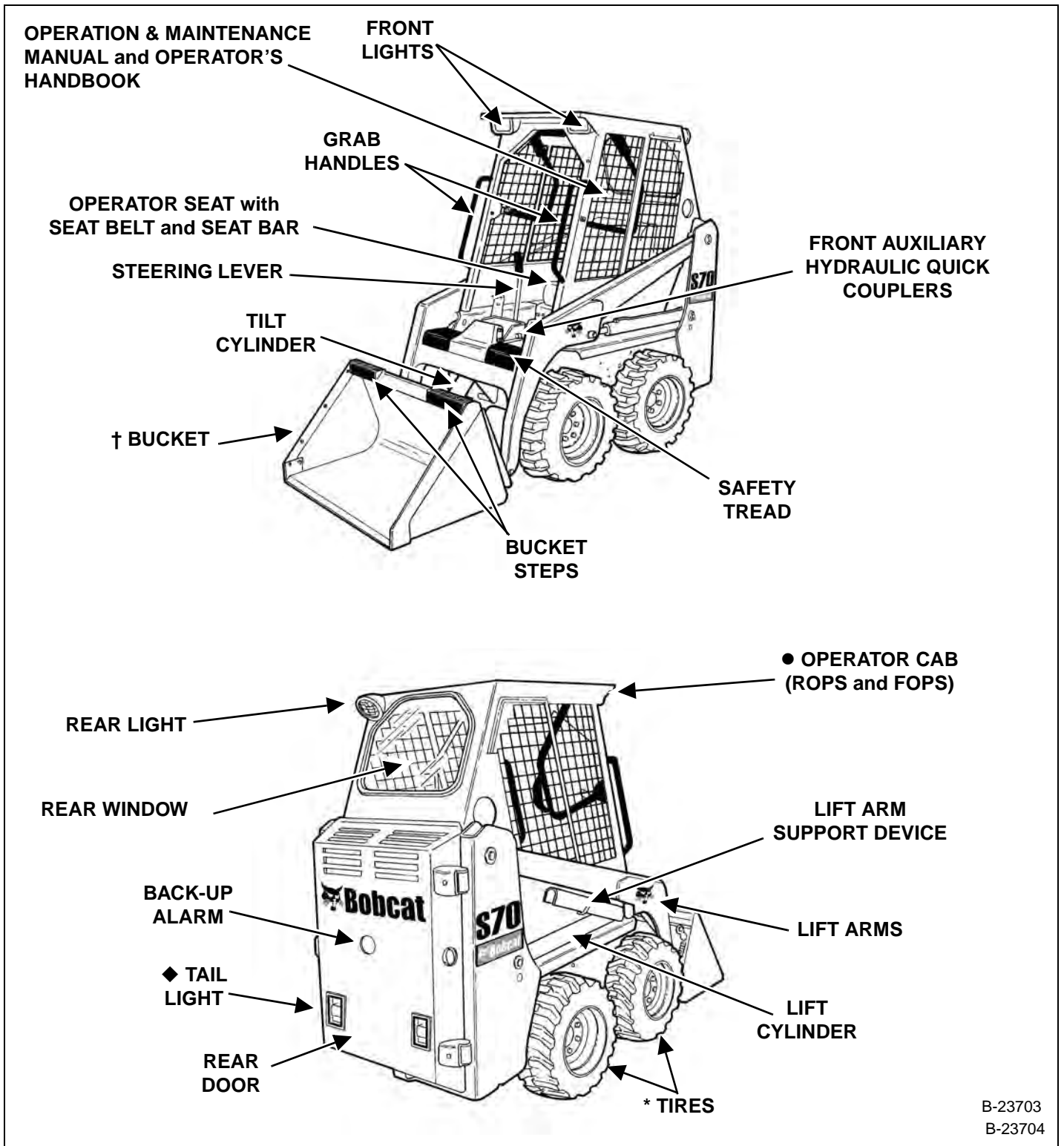

B-23703

B-23704

◆ OPTIONAL OR FIELD ACCESSORY (Not Standard Equipment).

\* TIRES - Bobcats are base-equipped with standard tires.

† BUCKET - Several different buckets and other attachments are available for the Bobcat Loader.

● ROPS - Roll-Over Protective Structure per ISO 3471 and FOPS - Falling-Object Protective Structure per ISO 3449, Level I.

## FEATURES, ACCESSORIES AND ATTACHMENTS

### Standard Items

Model S70 Bobcat Loaders are equipped with the following standard items:

- Adjustable Cushion Seat
- Auxiliary Hydraulics, Front
- Bobcat Interlock Control System (BICS™)
- Bob-Tach™
- Front Horn / Back-up Alarm
- Instrumentation: Hourmeter, Engine Temperature and Warning Lights
- Lift Arm Support Device
- Lights, Front and Rear
- Operator Cab (ROPS and FOPS [Level I] Approved)
- Parking Brake
- Rear Window
- Seat Bar
- Seat Belt
- Spark Arrester Exhaust System
- Tires (Bobcat Standard Duty, 23 x 5.70 - 12, 4 PR)
- Work Lights - Rear

### Options And Accessories

Below is a list of some equipment available from your Bobcat Loader dealer as Dealer and / or Factory Installed Accessories and Factory Installed Options. See your Bobcat dealer for other available options, accessories and attachments.

- Adjustable Suspension Seat
- Attachment Control Kit
- Cab Door
- Cab Enclosure
- Cab Heater
- Catalytic Exhaust Purifier
- Dual Steering Damper
- Engine Heater
- Extended Pedals
- GPS System
- Hydraulic Bucket Positioning (Includes On/Off Selection)
- Keyless Start
- Lift Kit (For lifting entire loader)
- Locking Fuel Cap and Cover
- Rear Stabilizer Kit
- Rental Kit (Monitors Temperature and Pressure [Engine Oil and Hydraulic Oil])
- Rotating Beacon
- Seat Belt - 3 in. Wide
- Sound Reduction Kit (Reduces noise at operator ear)
- Special Applications Kit
- Strobe Light
- Tires:
  - Bobcat Heavy Duty, 23 x 8.50 - 12, 6 PR
- Tool Container
- Vinyl Cab Enclosure
- Warning Lights: Four-Way Flasher (Includes Direction Signals)
- Windows
  - Externally Removable Rear Window
  - Polycarbonate Rear Window
  - Side Windows
  - Top Window

***Specifications subject to change without notice and standard items may vary.***

## FEATURES, ACCESSORIES AND ATTACHMENTS (CONT'D)

These and other attachments are approved for use on this model loader. Do not use unapproved attachments. Attachments not manufactured by Bobcat may not be approved.

The versatile Bobcat Loader quickly turns into a multi-job machine with a tight-fit attachment hook-up ... from bucket to grapple to pallet fork to backhoe and a variety of other attachments.

See your Bobcat dealer for information about approved attachments and attachment Operation & Maintenance Manuals.

Increase the versatility of your Bobcat Loader with a variety of bucket styles and sizes.

### Buckets Available

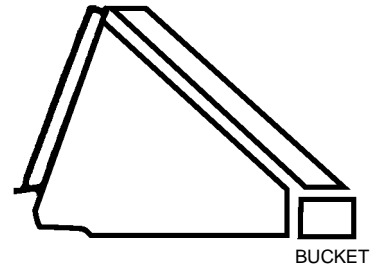

Many bucket styles, widths and different capacities are available for a variety of different applications. They include Construction & Industry, Low profile, Fertilizer and Snow, to name a few. See your Bobcat dealer for the correct bucket for your Bobcat Loader and application.

---

### Attachments

- Angle Broom
- Auger
- Backhoe
- Blades
  - Utility Blade
  - V-Blade
- Boring Unit
- Buckets
- Combination Bucket
- Digger
- Dumping Hopper
- Grapple
  - Industrial
  - Root
  - Utility
- Hydraulic Breaker
- Landplane
- Pallet Fork
- Scraper
- Snowblower
- Soil Conditioner
- Stump Grinder
- Sweeper
- Tiller
- Tree Fork
- Trencher
- Utility Forks
- Vibratory Plow
- X-Change™ Frame

## **WARNING**

### **AVOID INJURY OR DEATH**

Some attachment applications can cause flying debris or objects to enter front, top or rear cab openings. Install the Special Applications Kit to provide added operator protection in these applications.

W-2737-0508

### **Special Applications Kit Inspection And Maintenance**

- Inspect for cracks or damage. Replace if required.
- Pre-rinse with water to remove gritty materials.
- Wash with a mild household detergent and warm water.
- Use a sponge or soft cloth. Rinse well with water and dry with a clean soft cloth or rubber squeegee.
- Do not use abrasive or highly alkaline cleaners.
- Do not clean with metal blades or scrapers.

### **Special Applications Kit**

**Figure 5**

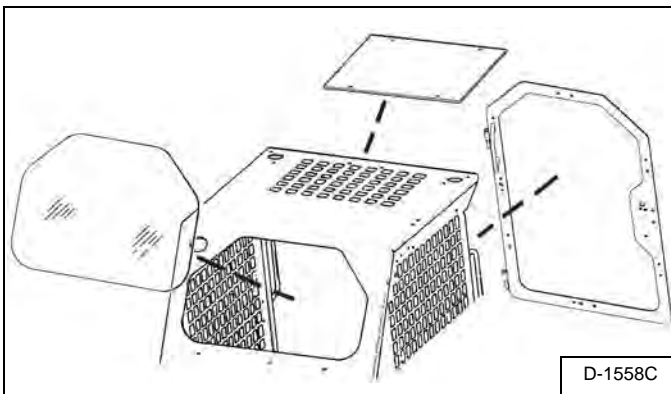

Available for special applications to restrict material from entering cab openings. Kit includes 12,7 mm (0.5 in) thick polycarbonate front door, 6,4 mm (0.25 in) thick polycarbonate top and rear windows **[Figure 5]**.

See your Bobcat dealer for availability.

## **SAFETY AND TRAINING RESOURCES**

SAFETY INSTRUCTIONS .....	15
Before Operation .....	15
Safe Operation Is The Operator's Responsibility .....	16
Safe Operation Needs A Qualified Operator .....	16
Avoid Silica Dust .....	17
FIRE PREVENTION .....	17
Maintenance .....	17
Operation .....	17
Electrical .....	17
Hydraulic System .....	18
Fueling .....	18
Starting .....	18
Spark Arrester Exhaust System .....	18
Welding And Grinding .....	18
Fire Extinguishers .....	18
MACHINE SIGNS (DECALS) .....	20
PUBLICATIONS AND TRAINING RESOURCES .....	22



**Bobcat®**



## SAFETY INSTRUCTIONS

### Before Operation

Carefully follow the operating and maintenance instructions in this manual.

The Bobcat loader is highly maneuverable and compact. It is rugged and useful under a wide variety of conditions. This presents an operator with hazards associated with off highway, rough terrain applications, common with Bobcat loader usage.

The Bobcat loader has an internal combustion engine with resultant heat and exhaust. All exhaust gases can kill or cause illness so use the loader with adequate ventilation.

The dealer explains the capabilities and restrictions of the Bobcat loader and attachment for each application. The dealer demonstrates the safe operation according to Bobcat instructional materials, which are also available to operators. The dealer can also identify unsafe modifications or use of unapproved attachments. The attachments and buckets are designed for a Rated Operating Capacity (some have restricted lift heights). They are designed for secure fastening to the Bobcat loader. The user must check with the dealer, or Bobcat literature, to determine safe loads of materials of specified densities for the machine - attachment combination.

The following publications and training materials provide information on the safe use and maintenance of the Bobcat machine and attachments:

- The Delivery Report is used to assure that complete instructions have been given to the new owner and that the machine and attachment is in safe operating condition.
- The Operation & Maintenance Manual delivered with the machine or attachment gives operating information as well as routine maintenance and service procedures. It is a part of the machine and can be stored in a container provided on the machine. Replacement Operation & Maintenance Manuals can be ordered from your Bobcat dealer.
- Machine signs (decals) instruct on the safe operation and care of your Bobcat machine or attachment. The signs and their locations are shown in the Operation & Maintenance Manual. Replacement signs are available from your Bobcat dealer.

- An Operator's Handbook is fastened to the operator cab of the loader. It's brief instructions are convenient to the operator. The handbook is available from your dealer in an English edition or one of many other languages. See your Bobcat dealer for more information on translated versions.
- The AEM Safety Manual delivered with the machine gives general safety information.
- The Skid-Steer Loader Operating Training Course is available through your Bobcat dealer. This course is intended to provide rules and practices of correct operation of the Bobcat loader. The course is available in English and Spanish versions.
- Service Safety Training Courses are available from your Bobcat dealer. They provide information for safe and correct service procedures.
- See the PUBLICATIONS AND TRAINING RESOURCES Page in this manual or your Bobcat dealer for Service and Parts Manuals, printed materials, videos, or training courses available. Also check the Bobcat web sites [www.training.bobcat.com](http://www.training.bobcat.com) or [www.bobcat.com](http://www.bobcat.com)

The dealer and owner / operator review the recommended uses of the product when delivered. If the owner / operator will be using the machine for a different application(s) he or she must ask the dealer for recommendations on the new use.



**Call Before You Dig**  
**Dial 811 (USA Only)**  
**1-888-258-0808 (USA & Canada)**

When you call, you will be directed to a location in your state / province, or city for information about buried lines (telephone, cable TV, water, sewer, gas, etc.).

## SAFETY INSTRUCTIONS (CONT'D)

### Safe Operation Is The Operator's Responsibility



Operator must have instructions before operating the machine. Untrained operators can cause injury or death.

W-2001-1285



This notice identifies procedures which must be followed to avoid damage to the machine.

I-2019-0284



The signal word DANGER on the machine and in the manuals indicates a hazardous situation which, if not avoided, will result in death or serious injury.

D-1002-1107



The signal word WARNING on the machine and in the manuals indicates a potentially hazardous situation which, if not avoided, could result in death or serious injury.

W-2044-1107

The Bobcat loader and attachment must be in good operating condition before use.

Check all of the items on the Bobcat Service Schedule Decal under the 8-10 hour column or as shown in the Operation & Maintenance Manual.

### Safe Operation Needs A Qualified Operator

For an operator to be qualified, he or she must not use drugs or alcoholic drinks which impair alertness or coordination while working. An operator who is taking prescription drugs must get medical advice to determine if he or she can safely operate a machine.

*A Qualified Operator Must Do The Following:*

*Understand the Written Instructions, Rules and Regulations*

- The written instructions from Bobcat Company include the Delivery Report, Operation & Maintenance Manual, Operator's Handbook, Safety Manual and machine signs (decals).
- Check the rules and regulations at your location. The rules may include an employer's work safety requirements. Regulations may apply to local driving requirements or use of a Slow Moving Vehicle (SMV) emblem. Regulations may identify a hazard such as a utility line.

*Have Training with Actual Operation*

- Operator training must consist of a demonstration and verbal instruction. This training is given by your Bobcat dealer before the product is delivered.
- The new operator must start in an area without bystanders and use all the controls until he or she can operate the machine and attachment safely under all conditions of the work area. Always fasten seat belt before operating.
- Operator Training Courses are available from your Bobcat dealer in English and Spanish. They provide information for safe and efficient equipment operation. Safety videos are also available.
- Service Safety Training Courses are available from your Bobcat dealer. They provide information for safe and correct service procedures.

*Know the Work Conditions*

- Know the weight of the materials being handled. Avoid exceeding the Rated Operating Capacity (ROC) of the machine. Material which is very dense will be heavier than the same volume of less dense material. Reduce the size of the load if handling dense material.
- The operator must know any prohibited uses or work areas, for example, he or she needs to know about excessive slopes.
- Know the location of any underground lines. Call local utilities or the TOLL FREE phone number found in the *Before Operation* section of this manual.
- Wear tight fitting clothing. Always wear safety glasses when doing maintenance or service. Safety glasses, respiratory equipment, hearing protection or Special Applications Kits are required for some work. See your Bobcat dealer about Bobcat safety equipment for your model.

SI SSL-0913

## SAFETY INSTRUCTIONS (CONT'D)

### Avoid Silica Dust



Cutting or drilling concrete containing sand or rock containing quartz may result in exposure to silica dust. Do not exceed Permissible Exposure Limits (PEL) to silica dust as determined by OSHA or other job site Rules and Regulations. Use a respirator, water spray or other means to control dust. Silica dust can cause lung disease and is known to the state of California to cause cancer.

## FIRE PREVENTION



### Maintenance

The machine and some attachments have components that are at high temperatures under normal operating conditions. The primary source of high temperatures is the engine and exhaust system. The electrical system, if damaged or incorrectly maintained, can be a source of arcs or sparks.

Flammable debris (leaves, straw, etc.) must be removed regularly. If flammable debris is allowed to accumulate, it can cause a fire hazard. Clean often to avoid this accumulation. Flammable debris in the engine compartment is a potential fire hazard.

The operator's area, engine compartment and engine cooling system must be inspected every day and cleaned if necessary to prevent fire hazards and overheating.

All fuels, most lubricants and some coolant mixtures are flammable. Flammable fluids that are leaking or spilled onto hot surfaces or onto electrical components can cause a fire.

### Operation

Do not use the machine where exhaust, arcs, sparks or hot components can contact flammable material, explosive dust or gases.

### Electrical



Check all electrical wiring and connections for damage. Keep the battery terminals clean and tight. Repair or replace any damaged part or wires that are loose or frayed.

Battery gas can explode and cause serious injury. Use the procedure in the Operation & Maintenance Manual for connecting the battery and for jump starting. Do not jump start or charge a frozen or damaged battery. Keep any open flames or sparks away from batteries. Do not smoke in battery charging area.

SI SSL-0913

## FIRE PREVENTION (CONT'D)

### Hydraulic System

Check hydraulic tubes, hoses and fittings for damage and leakage. Never use open flame or bare skin to check for leaks. Hydraulic tubes and hoses must be properly routed and have adequate support and secure clamps. Tighten or replace any parts that show leakage.

Always clean fluid spills. Do not use gasoline or diesel fuel for cleaning parts. Use commercial nonflammable solvents.

### Fueling



Stop the engine and let it cool before adding fuel. No smoking! Do not refuel a machine near open flames or sparks. Fill the fuel tank outdoors.

Ultra Low Sulfur Diesel (ULSD) poses a greater static ignition hazard than earlier diesel formulations with higher Sulfur content. Avoid death or serious injury from fire or explosion. Consult with your fuel or fuel system supplier to ensure the delivery system is in compliance with fueling standards for proper grounding and bonding practices.

### Starting

Do not use ether or starting fluids on any engine that has glow plugs or air intake heater. These starting aids can cause explosion and injure you or bystanders.

Use the procedure in the Operation & Maintenance Manual for connecting the battery and for jump starting.

### Spark Arrester Exhaust System

The spark arrester exhaust system is designed to control the emission of hot particles from the engine and exhaust system, but the muffler and the exhaust gases are still hot.

Check the spark arrester exhaust system regularly to make sure it is maintained and working properly. Use the procedure in the Operation & Maintenance Manual for cleaning the spark arrester muffler (if equipped).

## Welding And Grinding

Always clean the machine and attachment, disconnect the battery, and disconnect the wiring from the Bobcat controllers before welding. Cover rubber hoses, battery and all other flammable parts. Keep a fire extinguisher near the machine when welding.

Have good ventilation when grinding or welding painted parts. Wear dust mask when grinding painted parts. Toxic dust or gas can be produced.

Dust generated from repairing nonmetallic parts such as hoods, fenders or covers can be flammable or explosive. Repair such components in a well ventilated area away from open flames or sparks.

### Fire Extinguishers

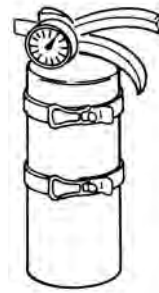

Know where fire extinguishers and first aid kits are located and how to use them. Inspect the fire extinguisher and service the fire extinguisher regularly. Obey the recommendations on the instructions plate.



**Bobcat**®



# MACHINE SIGNS (DECALS) (CONT'D)

Follow the instructions on all the Machine Signs (Decals) that are on the loader. Replace any damaged machine signs and be sure they are in the correct locations. Machine signs are available from your Bobcat loader dealer.

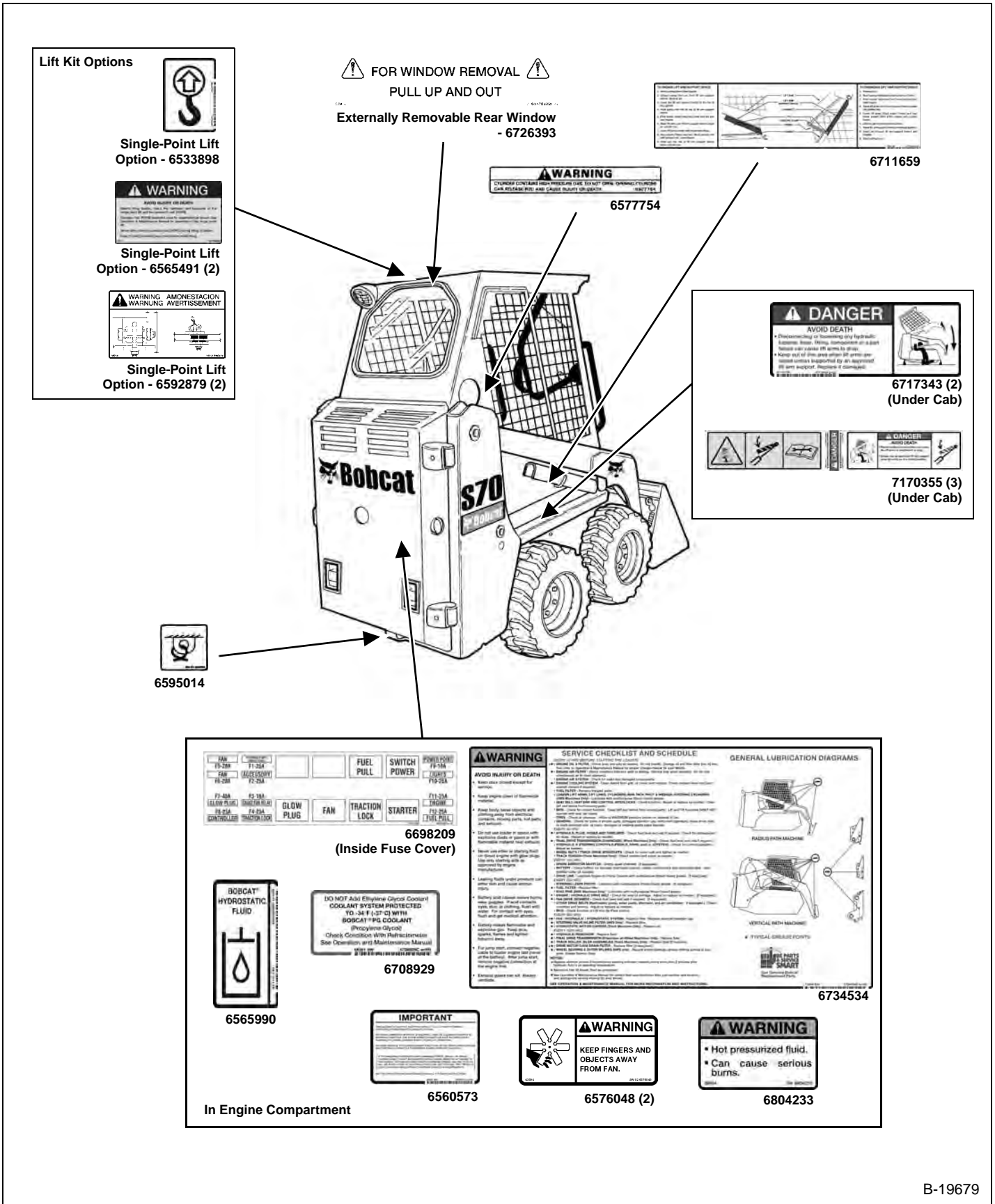

## PUBLICATIONS AND TRAINING RESOURCES

The following publications are also available for your Bobcat loader. You can order them from your Bobcat dealer.

For the latest information on Bobcat products and the Bobcat Company, visit our Web site at [www.training.bobcat.com](http://www.training.bobcat.com) or [www.bobcat.com](http://www.bobcat.com).



### OPERATION & MAINTENANCE MANUAL

6986660enUS

Complete instructions on the correct operation and the routine maintenance of your Bobcat loader.



### OPERATOR'S HANDBOOK

6986661

Gives basic operation instructions and safety warnings.



### SAFETY MANUAL

6556500 (English and Spanish)

Gives basic safety procedures and warnings for your Bobcat loader.



### OPERATOR SAFETY DVD

6904762 (English and Spanish)

DVD gives basic safety instructions for many Bobcat products including loaders.



### SKID-STEER LOADER OPERATOR TRAINING COURSE

6901726 (English)

6902289 (Spanish)

Introduces operator to step-by-step basics of skid-steer loader operation.



### SKID-STEER LOADER SERVICE SAFETY TRAINING COURSE

6900641

Introduces service technicians to step-by-step basics of proper and safe skid-steer loader maintenance and servicing procedures.

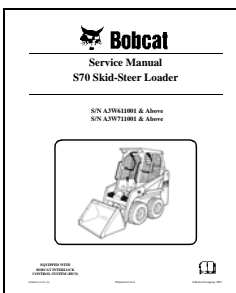

### SERVICE MANUAL

6986662

Complete maintenance instructions for your Bobcat loader.



### LOADER SAFETY VIDEO

(Mobile device with quick response code application required)

Scan the code above to watch the loader safety video or view at [www.training.bobcat.com](http://www.training.bobcat.com).



## OPERATING INSTRUCTIONS

INSTRUMENT PANEL IDENTIFICATION .....	27
Left And Right Panels .....	27
Standard Key Panel .....	28
Keyless Start Panel .....	28
Option And Field Accessory Panel .....	29
Cab Heater Panel .....	29
CONTROL IDENTIFICATION .....	30
Standard Controls .....	30
SEAT BAR RESTRAINT SYSTEM .....	31
Operation .....	31
BOBCAT INTERLOCK CONTROL SYSTEM (BICS™) .....	32
Operation .....	32
LIFT ARM BYPASS CONTROL .....	33
Operation .....	33
PARKING BRAKE .....	33
Operation .....	33
TRACTION LOCK OVERRIDE .....	34
Operation .....	34
EMERGENCY EXIT .....	35
Rear Window .....	35
Front Door .....	35
BACK-UP ALARM SYSTEM .....	36
Description .....	36
Operation .....	36
ENGINE SPEED CONTROL .....	37
Operation .....	37
DRIVING AND STEERING THE LOADER .....	38
Operation .....	38
STOPPING THE LOADER .....	38
Using The Control Levers .....	38

HYDRAULIC CONTROLS .....	39
Description .....	39
Hydraulic Bucket Positioning .....	39
Auxiliary Hydraulic Control Lockout .....	39
Front Auxiliary Hydraulics Operation .....	40
Quick Couplers .....	41
Relieve Auxiliary Hydraulic Pressure (Loader And Attachment) .....	41
ATTACHMENT CONTROL DEVICE (ACD) .....	42
Description .....	42
DAILY INSPECTION .....	43
Daily Inspection And Maintenance .....	44
PRE-STARTING PROCEDURE .....	45
Entering The Loader .....	45
Operation & Maintenance Manual And Operator's Handbook Locations .....	45
Seat Adjustment .....	46
Seat Belt Adjustment .....	47
Seat Bar .....	47
STARTING THE ENGINE .....	48
Standard Key Panel .....	48
Keyless Start Panel .....	50
Cold Temperature Starting .....	52
Warming The Hydraulic / Hydrostatic System .....	52
MONITORING THE DISPLAY PANELS .....	52
Right Panel .....	52
STOPPING THE ENGINE AND LEAVING THE LOADER .....	53
Procedure .....	53
ATTACHMENTS .....	54
Choosing The Correct Bucket .....	54
Pallet Forks .....	54
Installing And Removing The Attachment .....	55
OPERATING PROCEDURE .....	58
Inspect The Work Area .....	58
Basic Operating Instructions .....	58
Driving On Public Roads .....	58
Operating With A Full Bucket .....	59
Operating With An Empty Bucket .....	59
Filling And Emptying The Bucket .....	60
Leveling The Ground Using Float .....	61
Digging And Filling A Hole .....	61
TOWING THE LOADER .....	62
Procedure .....	62

LIFTING THE LOADER .....	.63
Single-Point Lift .....	.63
TRANSPORTING THE LOADER ON A TRAILER .....	.63
Loading And Unloading .....	.63
Fastening .....	.64



**Bobcat®**

## INSTRUMENT PANEL IDENTIFICATION

### Left And Right Panels

Figure 6

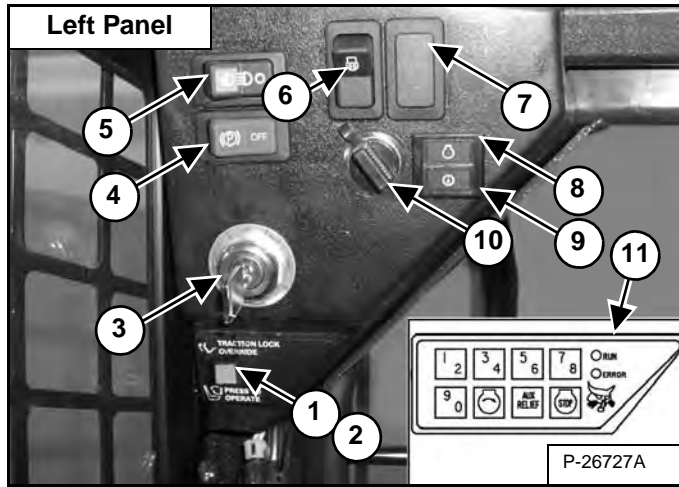
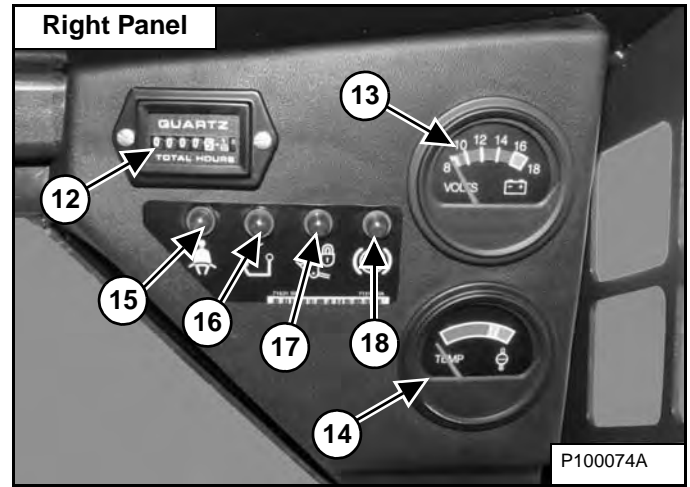

Figure 7



The table below shows the DESCRIPTION and FUNCTION / OPERATION for each of the instrument panel components.

REF.	DESCRIPTION	FUNCTION / OPERATION
1	TRACTION LOCK OVERRIDE BUTTON	<i>(Functions Only When The Seat Bar Is Raised, the Parking Brake Switch is OFF and the Engine Is Running.)</i> Allows you to use the steering levers to move the loader forward or backward when using the backhoe attachment. (See TRACTION LOCK OVERRIDE in this manual.) Engages auxiliary hydraulics.
2	PRESS TO OPERATE LOADER BUTTON	<i>(Functions Only When The Seat Bar Is Down.)</i> Activates BICS™ when the Seat Bar is down and operator is seated in the operating position. Engages auxiliary hydraulics.
3	KEY SWITCH	For starting and stopping the engine. (See Standard Key Panel in this manual.)
4	PARKING BRAKE	Press the left side of switch to engage; press right side to disengage.
5	LIGHT SWITCH	For FRONT work lights, “red” rear light, and REAR work light: Press the switch fully to the right to turn all lights OFF. Press the switch to the center position to turn on the FRONT work lights and “red” rear light. Press the switch fully to the left to turn on the FRONT work lights and REAR work light.
6	PREHEAT SWITCH	Press and hold to preheat the glow plugs to aid in cold temperature starting. (Earlier Models)
7	NOT USED	- - -
8	ENGINE WARNING LIGHT	Light is ON when engine oil pressure is low or coolant temperature is high. Stop the engine if the light comes ON.
9	TRANSMISSION WARNING LIGHT	Light is ON when transmission charge pressure is low, hydraulic filter needs replacement or fluid temperature is high. Stop the engine if the light comes ON.
10	POWER PLUG	Used to power 12 volt accessories.
11	KEYLESS PANEL	Optional Keyless Panel Kit. (See Keyless Start Panel in this manual.)
12	HOURMETER	Records the total operating hours of the loader.
13	VOLTMETER	Shows the condition of the battery and the rate of charge.
14	ENGINE TEMPERATURE GAUGE	Shows the engine coolant temperature.
15	SEAT BELT INDICATOR LIGHT	Light stays on for 45 seconds to remind operator to fasten seat belt.
16	SEAT BAR LIGHT	Light is ON when the seat bar is raised.
17	LIFT & TILT VALVE LIGHT	Light is ON when the lift and tilt functions can <b>NOT</b> be operated. Light is OFF when the seat bar is down, the key switch is in the ON position and the PRESS TO OPERATE Loader Button is pressed. The lift and tilt functions <b>can</b> be operated when the light is OFF.
18	PARKING BRAKE LIGHT	Light is ON when the Parking Brake is engaged.

## INSTRUMENT PANEL IDENTIFICATION (CONT'D)

### Standard Key Panel

Figure 8

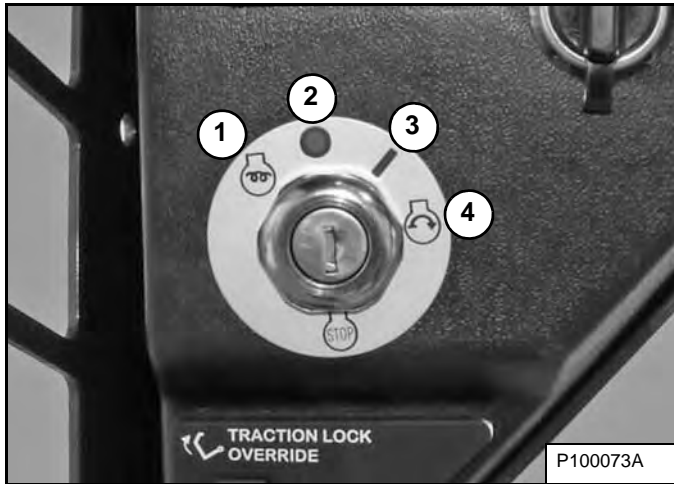

The functions of the Key Switch [Figure 8] are:

1. **ENGINE PREHEAT:** Hold the key in this position to activate the glow pugs. (Earlier model loaders have a separate preheat switch and do not have this position.) (See Left And Right Panels on Page 27.)
2. **STOP:** Stop the engine and turn the loader electrical system OFF.
3. **RUN:** Turn the loader electrical system ON.
4. **START:** Hold the key in this position to start the engine; release when engine starts.

### Keyless Start Panel

Figure 9

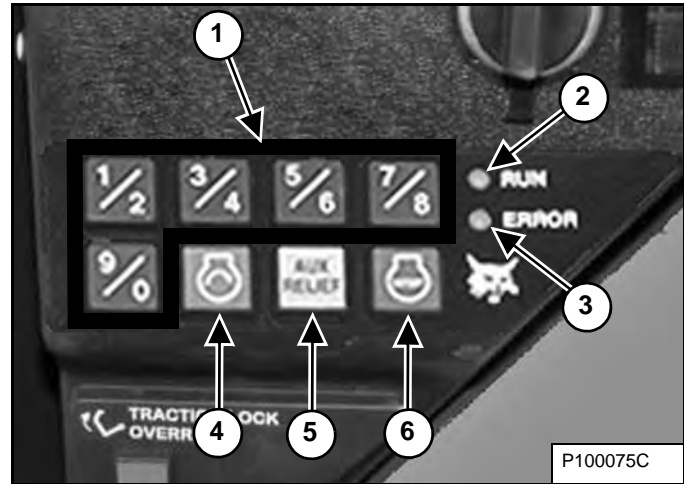

The functions of the Keyless Start Panel [Figure 9] are:

1. **KEYPAD (Keys 1 through 0):** Used to enter a number code (password) to allow starting the engine.
2. **RUN LIGHT:** Light will be ON after the password has been correctly entered.
3. **ERROR LIGHT:** Light will be ON when an incorrect user / master password is entered. Three consecutive incorrect passwords will cause an error condition and a delay of one minute will be required before another start sequence can be attempted.
4. **START Button:** Press the start button until the engine starts.
5. **AUX. RELIEF / PREHEAT Button:** Press and hold to activate the glow pugs after the password has been entered.
6. **STOP Button:** Used to stop the engine and shut down the loader electrical system.

**NOTE:** When a Keyless Start Panel Kit is installed, the kit will be supplied with an Owner Password. Change the password to one that you will easily remember to prevent unauthorized use of your loader. Keep your password in a safe place for future needs. (The instructions included with the Keyless Start Panel will describe how to change the password. Keep this instruction for future reference.)

## INSTRUMENT PANEL IDENTIFICATION (CONT'D)

### Option And Field Accessory Panel

Figure 10

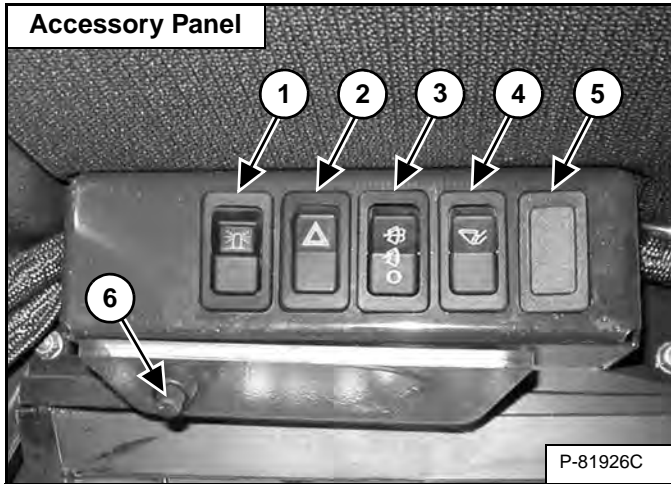

The side accessory panel is shown in [Figure 10].

REF. NO.	DESCRIPTION	FUNCTION / OPERATION
1	ROTATING BEACON (Option) <b>OR</b> STROBE LIGHT (Option)	Press the top of the switch to turn ON; press bottom to turn OFF.
2	HAZARD LIGHTS (Option)	Press the top of the switch to turn the Hazard Lights ON; press bottom to turn OFF.
3	FRONT WINDSHIELD WIPER (Option)	Move the switch to the center position to turn ON; press bottom to turn OFF. Press and hold the top of switch for washer fluid.
4	HYDRAULIC BUCKET POSITIONING (Option)	The Bucket Positioning function will keep the bucket in approximately the same position as the lift arms are raised. Press the top of the switch to engage the Bucket Position function; press the bottom to disengage.
5	NOT USED	- - -
6	CAB LIGHT (Option) (Earlier Models)	Press the switch to turn ON, press again to turn OFF.

### Later Model Cab Light (If Equipped)

Figure 11

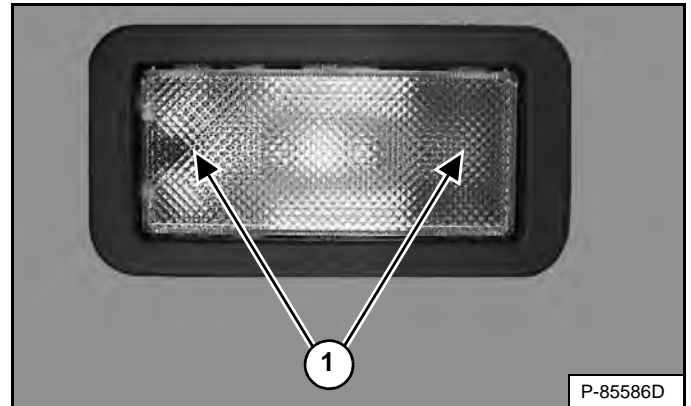

Push either side of the lens (Item 1) [Figure 11] to turn the light ON. Return the lens to the middle position to turn the light OFF.

### Cab Heater Panel

This machine may be equipped with a Cab Heater.

Figure 12

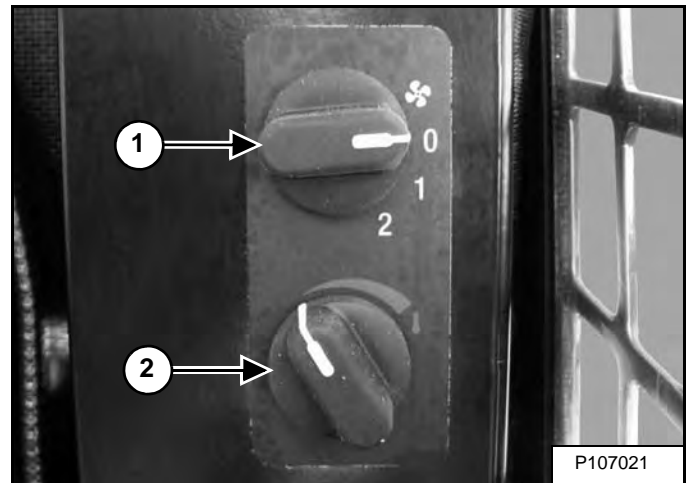

The cab heater panel is shown in [Figure 12].

REF. NO.	DESCRIPTION	FUNCTION / OPERATION
1	FAN MOTOR (Option)	Turn clockwise to increase fan speed; counterclockwise to decrease. There are three positions; OFF-1-2.
2	TEMPERATURE CONTROL (Option)	Turn clockwise to increase the temperature; counterclockwise to decrease.

## CONTROL IDENTIFICATION

### Standard Controls

Figure 13

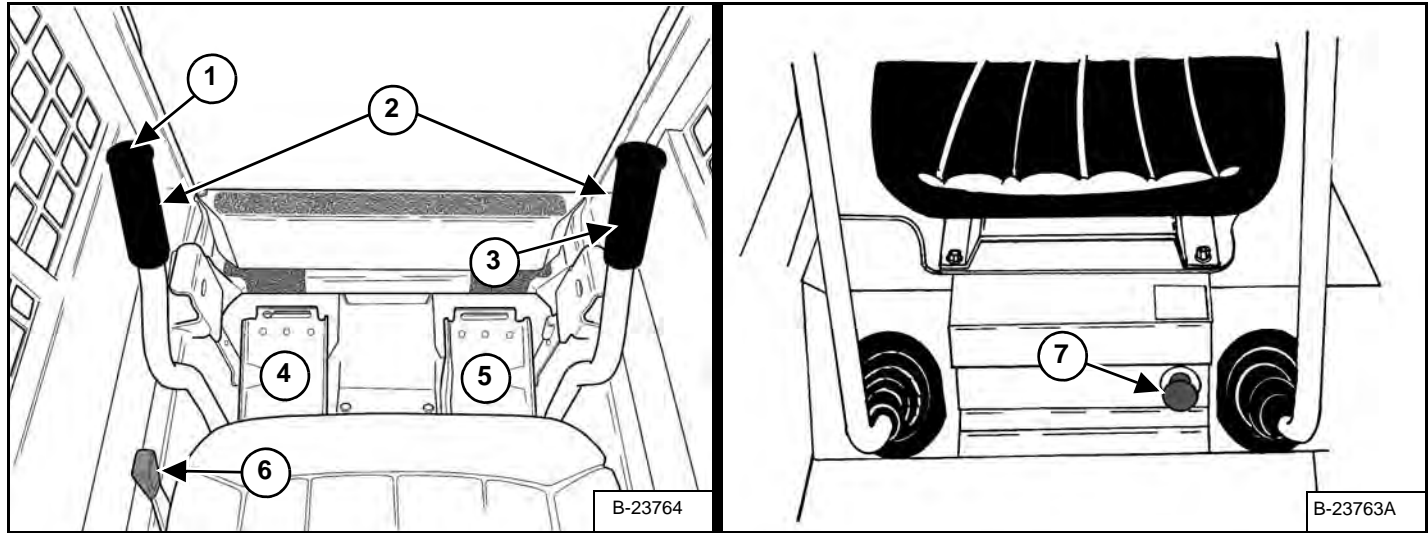

REF. NO.	DESCRIPTION	FUNCTION / OPERATION
* 1	FRONT HORN	Press the button to sound the front horn.
2	STEERING LEVERS	See DRIVING AND STEERING THE LOADER in this manual.
3	AUXILIARY HYDRAULICS CONTROL	See HYDRAULIC CONTROLS in this manual.
4	LIFT ARM PEDAL	See HYDRAULIC CONTROLS in this manual.
5	TILT PEDAL	See HYDRAULIC CONTROLS in this manual.
6	ENGINE SPEED CONTROL	See ENGINE SPEED CONTROL in this manual.
7	LIFT ARM BYPASS CONTROL	See LIFT ARM BYPASS CONTROL in this manual.

\* Press the front switch to sound the front horn if equipped with deluxe hand grips.



## SEAT BAR RESTRAINT SYSTEM

### Operation

Figure 14



The seat bar restraint system has a pivoting seat bar with armrests (Item 1) [Figure 14].

## WARNING

### AVOID INJURY OR DEATH

When operating the machine:

- Keep the seat belt fastened snugly.
- The seat bar must be lowered.
- Keep your feet on the pedal controls and hands on steering levers.

W-2046-0108

The operator controls the use of the seat bar. The seat bar in the down position helps to keep the operator in the seat.

When the seat bar is down, the PRESS TO OPERATE LOADER button is activated, and the parking brake is released, the lift, tilt and traction drive functions can be operated.

When the seat bar is up, the lift, tilt and traction drive functions are deactivated. Both foot pedals will be locked when returned to the neutral position.

## WARNING

Before you leave the operator's seat:

- Lower the lift arms, put the attachment flat on the ground.
- Stop the engine.
- Engage the parking brake.
- Raise the seat bar, move pedals until both lock.
- Move auxiliary hydraulic control lever out of detent position.

W-2164-0108

## BOBCAT INTERLOCK CONTROL SYSTEM (BICS™)

### Operation

# ! WARNING

### AVOID INJURY OR DEATH

The Bobcat Interlock Control System (BICS™) must deactivate the lift, tilt and traction drive functions. If it does not, contact your dealer for service. **DO NOT** modify the system.

W-2151-1111

Figure 15



The Bobcat Interlock Control System (BICS™) has a pivoting seat bar with armrests (Item 1) [Figure 15]. The operator controls the use of the seat bar.

The BICS™ requires the operator to be seated in the operating position with the seat bar fully lowered before the lift, tilt, auxiliary hydraulics and traction functions can be operated. The seat belt must be fastened any time you operate the machine.

# ! WARNING

### AVOID INJURY OR DEATH

When operating the machine:

- Keep the seat belt fastened snugly.
- The seat bar must be lowered.
- Keep your feet on the pedal controls and hands on steering levers.

W-2046-0108

Figure 16

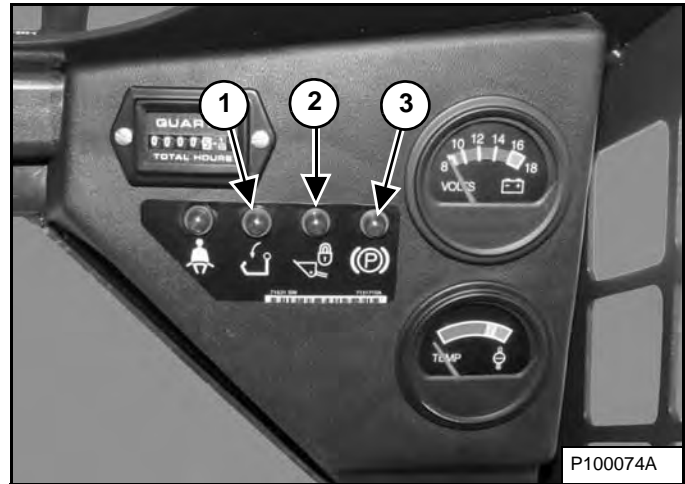

There are three display lights (Items 1, 2 and 3) [Figure 16] located on the right instrument panel that must be OFF to fully operate the machine.

When the seat bar is lowered, the engine is running, the PRESS TO OPERATE LOADER button is activated, and the parking brake is released, the lift, tilt, auxiliary hydraulics and traction drive functions can be operated.

When the seat bar is raised, the lift, tilt, auxiliary hydraulics and traction drive functions are deactivated.

# ! WARNING

Before you leave the operator's seat:

- Lower the lift arms, put the attachment flat on the ground.
- Stop the engine.
- Engage the parking brake.
- Raise the seat bar, move pedals until both lock.
- Move auxiliary hydraulic control lever out of detent position.

W-2164-0108

## LIFT ARM BYPASS CONTROL

### Operation

Figure 17

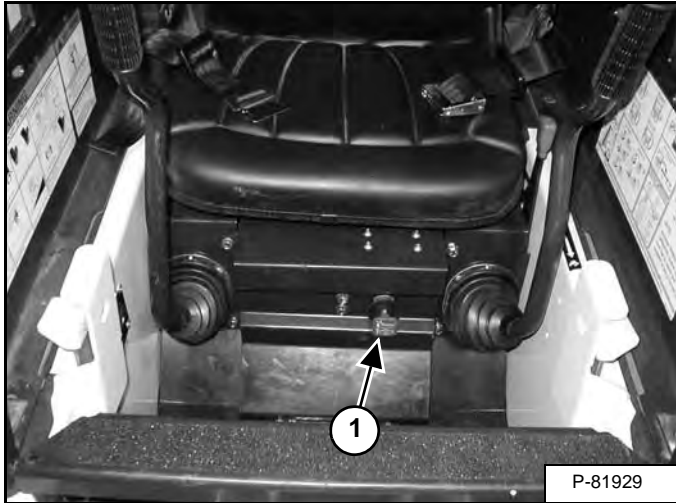

The lift arm bypass control (Item 1) [Figure 17] is used to lower the lift arms if the lift arms cannot be lowered during normal operations.

1. Sit in the operator seat.
2. Fasten the seat belt and lower the seat bar.
3. Turn the lift arm bypass knob (Item 1) [Figure 17] clockwise 1/4 turn.
4. Pull out and hold the knob until the lift arms lower.

## PARKING BRAKE

### Operation

Figure 18

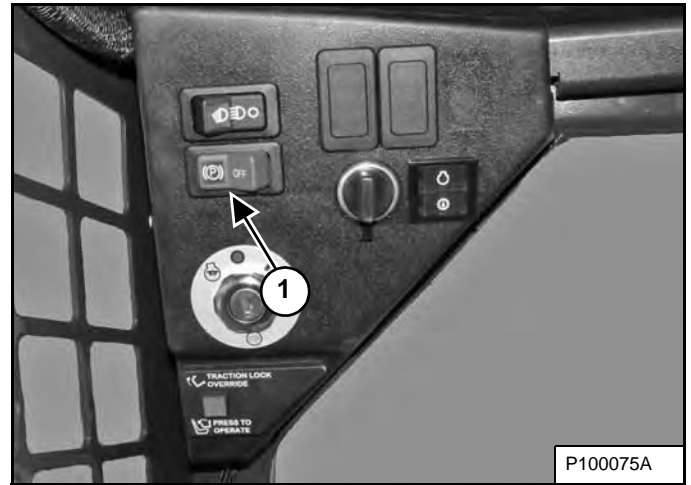

Press the left side of the switch (Item 1) [Figure 18] to engage the parking brake. The red light in the switch will turn on. The traction drive system will be locked.

Press the right side of the switch (Item 1) [Figure 18] to disengage the parking brake. The red light in the switch will turn off. The traction drive system will be unlocked.

**NOTE:** If the loader will not move when operator is in the operating position with the seat bar down and the parking brake disengaged and after the **PRESS TO OPERATE LOADER** button is pressed, move the steering levers either forward or backward a small amount to unlock the traction drive.

Figure 19



**NOTE:** The **PARKING BRAKE LIGHT** (Item 1) [Figure 19] on the right instrument panel will remain ON until the engine is started, the **PRESS TO OPERATE LOADER** button is pressed and the parking brake is disengaged.

## TRACTION LOCK OVERRIDE

### Operation

Figure 20



Figure 21



(Functions only when the seat bar is raised, the parking brake switch is OFF, and the engine is running.) There is a TRACTION LOCK OVERRIDE button (Item 1) [Figure 20] on the left instrument panel which will allow you to use the steering levers to move the loader forward and backward when using the backhoe attachment.

- Press the TRACTION LOCK OVERRIDE button once to unlock the brakes. The PARKING BRAKE light (Item 1) [Figure 21] will be OFF.
- Press the button a second time to lock the traction drive. The PARKING BRAKE light (Item 1) [Figure 21] will be ON.

## EMERGENCY EXIT

The front opening on the operator cab and rear window provide exits.

### Rear Window

Figure 22

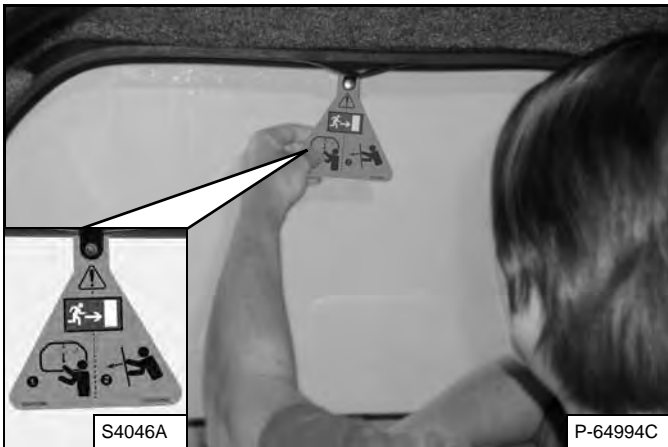

Pull the tag on the top of the rear window [Figure 22] to remove the rubber cord.

Push the rear window out of the rear of the operator cab.

Figure 23



Exit through the rear of the operator cab [Figure 23].

### Front Door

This machine may be equipped with a Front Door.

**NOTE:** When an Operator Cab Enclosure Kit is installed, the window of the front door can be used as an emergency exit [Figure 24].

**NOTE:** If the loader has a Special Application Door Kit installed, the window of the front door is **NOT** an emergency exit.

Figure 24

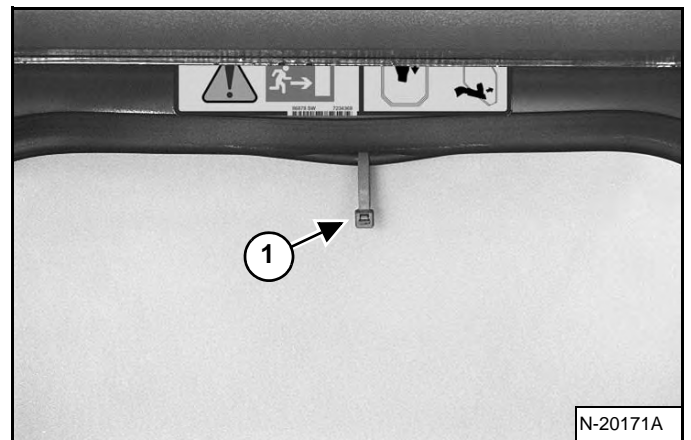

Pull the plastic loop (Item 1) [Figure 24] at the top of the window in the front door to remove the rubber cord.

Figure 25

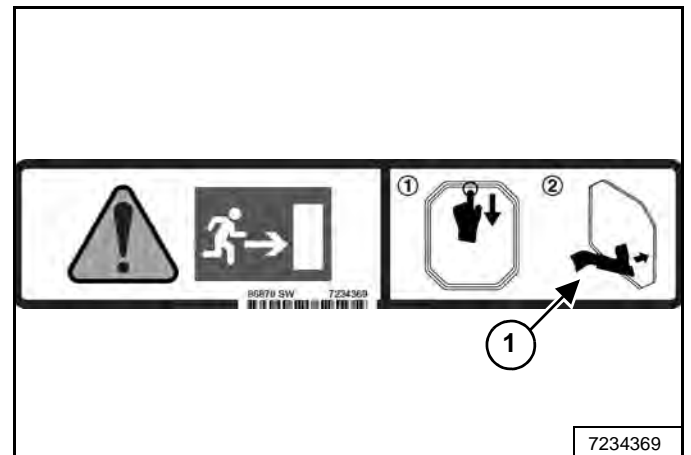

Push the window out with your foot at any corner of the window (Item 1) [Figure 25].

Exit through the front door.

## BACK-UP ALARM SYSTEM

### Description

Figure 26

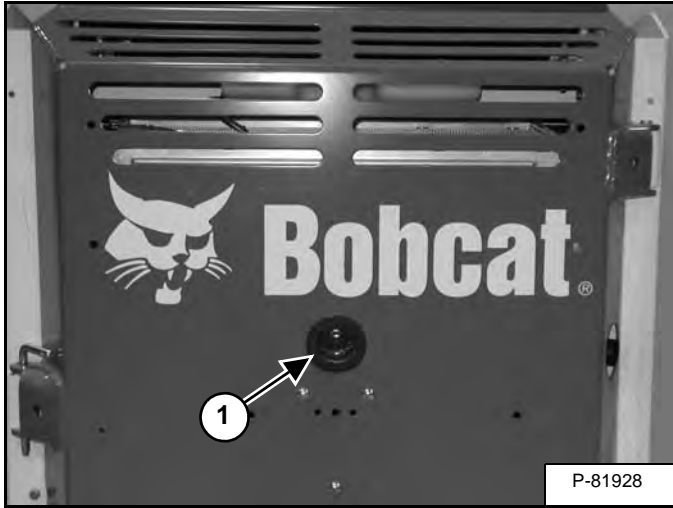

The back-up alarm (Item 1) [Figure 26] is located on the inside of the rear door.

**A back-up alarm is not a substitute for looking to the rear when operating the loader in reverse, or for keeping bystanders away from the work area.** Operators **must always** look in the direction of travel, including **reverse**, and must keep bystanders away from the work area, even though the loader is equipped with a back-up alarm.

Operators must be trained to **always** look in the direction of travel, **including when operating the loader in reverse** and to keep bystanders away from the work area. Other workers should be trained to **always** keep away from the operator's work area and travel path.

### Operation

## **WARNING**

### **AVOID INJURY OR DEATH**

- Always keep bystanders away from the work area and travel path.
- The operator must always look in the direction of travel.
- The back-up alarm must sound when operating the machine in the reverse direction.

W-2783-0409

The back-up alarm will sound when the operator moves both steering levers into the reverse position. Slight movement of the steering levers into the reverse position is required with hydrostatic transmissions, before the back-up alarm will sound.

If alarm does not sound or for adjustment instructions, see inspection and maintenance instructions for the back-up alarm system in the preventive maintenance section of this manual. (See BACK-UP ALARM SYSTEM on Page 78.)

## ENGINE SPEED CONTROL

### Operation

Figure 27

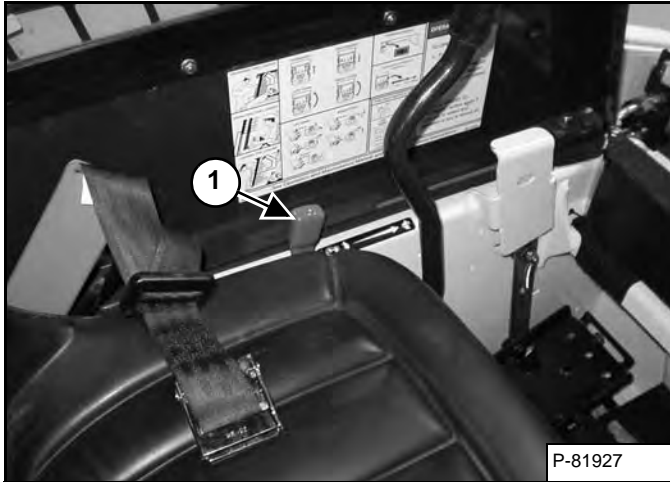

The engine speed control lever is to the left of the operator seat (Item 1) [Figure 27].

Move the lever forward to increase engine speed. Move backward to decrease engine speed.

## DRIVING AND STEERING THE LOADER

### Operation

Figure 28



The control levers (Item 1) [Figure 28] are on the left and right side in front of the seat.

Move the levers smoothly. Avoid sudden starting and stopping.

## **WARNING**

### AVOID INJURY OR DEATH

When operating the machine:

- Keep the seat belt fastened snugly.
- The seat bar must be lowered.
- Keep your feet on the pedal controls and hands on steering levers.

W-2046-0108

Figure 29

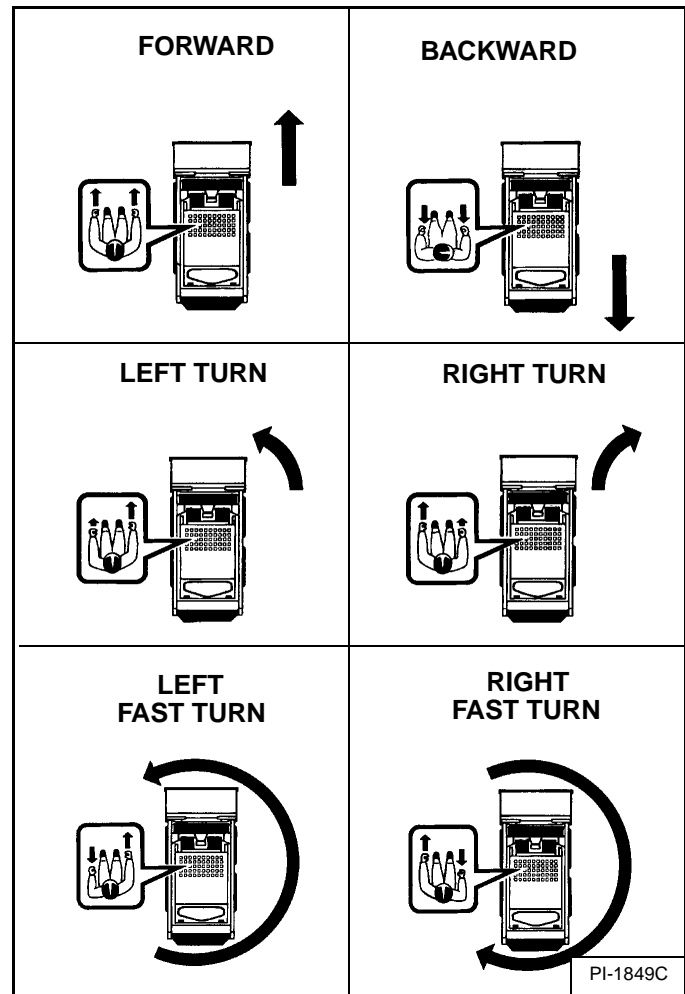

The levers control forward and backward travel and turning the loader [Figure 29].

**Forward Travel** - Push both levers forward.

**Backward Travel** - Pull both levers backward.

**Normal Turning** - Move one lever farther forward than the other.

**Fast Turning** - Push one lever forward and pull the other lever backward.

## STOPPING THE LOADER

### Using The Control Levers

When the steering levers are moved to the neutral position, the hydrostatic transmission will act as a *service brake* to stop the loader.



## HYDRAULIC CONTROLS

### Description

Two foot pedals control the hydraulic cylinders for the lift and tilt functions.

Put your feet on the pedals and **KEEP THEM THERE** any time you operate the loader.

**Figure 30**

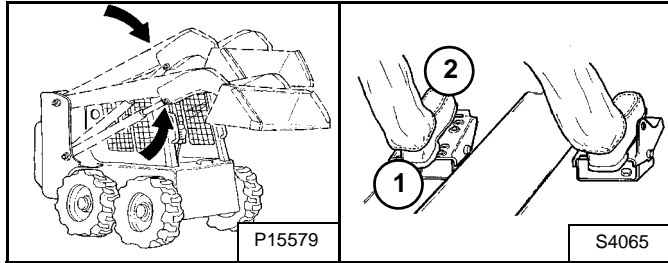

#### Lift Arm Operation (Left Pedal)

Push the heel (Item 1) **[Figure 30]** of the pedal to raise the lift arms.

Push the toe (Item 2) **[Figure 30]** of the pedal to lower the lift arms.

#### Lift Arm Float Position (Left Pedal)

Push the toe (Item 2) **[Figure 30]** of the pedal all the way forward until it locks into the float position.

Use the float position of the lift arms to level loose material while driving backward.

Raise the lift arms to disengage the float position.

**Figure 31**

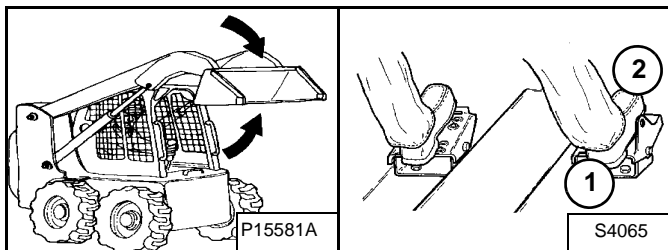

#### Tilt Operation - (Right Pedal)

Push the heel (Item 1) **[Figure 31]** of the pedal to tilt the bucket backward.

Push the toe (Item 2) **[Figure 31]** of the pedal to tilt the bucket forward.

### Hydraulic Bucket Positioning

This machine may be equipped with Hydraulic Bucket Positioning.

The function of hydraulic bucket positioning is to keep the bucket in the same approximate position it is in before you begin raising the lift arms.

**Figure 32**

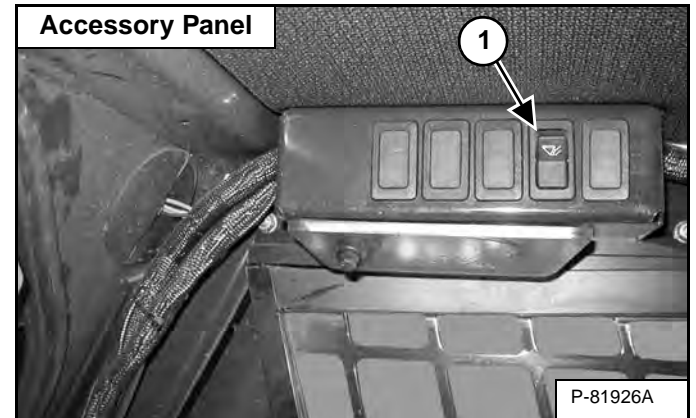

Press the top of the BUCKET POSITIONING switch (Item 1) **[Figure 32]** to engage the bucket positioning function. Press the bottom of the switch to disengage this function.

Bucket positioning functions only during upward lift cycle.

### Auxiliary Hydraulic Control Lockout

**Figure 33**

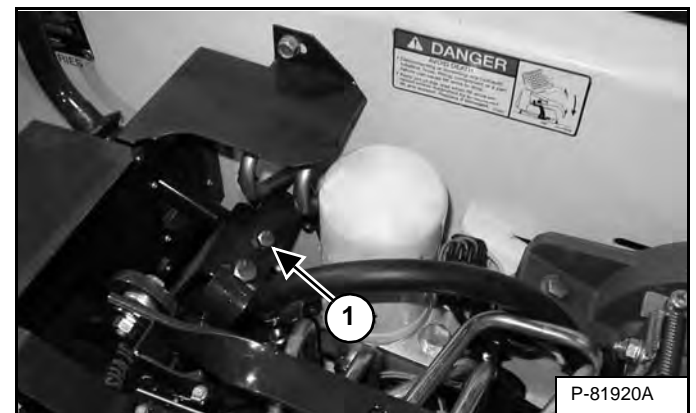

Raise the operator cab. (See OPERATOR CAB on Page 80.)

Remove the auxiliary hydraulic control lockout bolt and nut (Item 1) **[Figure 33]** before using the auxiliary control for the first time.

Lower the operator cab. (See OPERATOR CAB on Page 80.)

## HYDRAULIC CONTROLS (CONT'D)

### Front Auxiliary Hydraulics Operation

#### Variable Flow

**Figure 34**

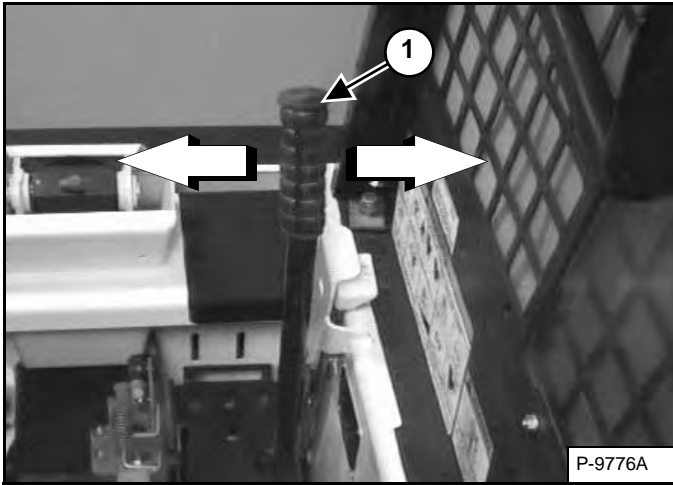

Variable Flow allows for slow-to-fast movement of auxiliary hydraulic functions.

The right steering lever (Item 1) [Figure 34] is also the control lever for the front auxiliary hydraulics (Auxiliary Hydraulic Control Lever).

Enter the loader, lower the seat bar, fasten seat belt, engage the parking brake and start the engine. Press the PRESS TO OPERATE LOADER button which will also engage the auxiliary hydraulics.

**Figure 35**

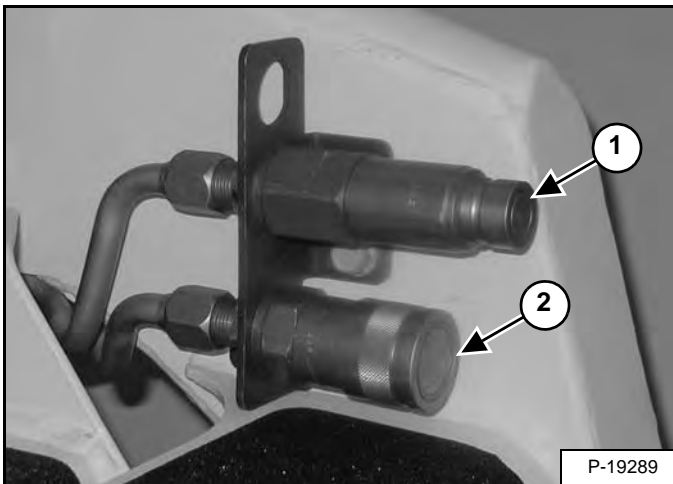

Move the Auxiliary Hydraulic Control Lever (Item 1) [Figure 34] to the left for auxiliary hydraulic oil flow to the front male coupler (Item 1) [Figure 35]. Hydraulic oil flow increases to the coupler as the lever is moved to the left.

Move the Auxiliary Hydraulic Control Lever (Item 1) [Figure 34] to the right for auxiliary hydraulic oil flow to the front female coupler (Item 2) [Figure 35]. Hydraulic oil flow increases to the coupler as the lever is moved to the right.

#### Continuous Flow

Continuous Flow allows for fast movement of auxiliary hydraulic functions.

Move the Auxiliary Hydraulic Control Lever fully to the right to put it into continuous flow (detent) position. This will allow continuous auxiliary hydraulic oil flow to the female coupler. Move the lever to the neutral position to stop auxiliary hydraulic oil flow

Move the lever out of the continuous flow (detent) position before leaving the operator's seat.

**NOTE: When the operator is seated and raises the seat bar, the Auxiliary Hydraulic System will deactivate.**

## HYDRAULIC CONTROLS (CONT'D)

### Quick Couplers

# ! WARNING

### AVOID BURNS

Hydraulic fluid, tubes, fittings and quick couplers can get hot when running machine and attachments. Be careful when connecting and disconnecting quick couplers.

W-2220-0396

# ! WARNING

### AVOID INJURY OR DEATH

Diesel fuel or hydraulic fluid under pressure can penetrate skin or eyes, causing serious injury or death. Fluid leaks under pressure may not be visible. Use a piece of cardboard or wood to find leaks. Do not use your bare hand. Wear safety goggles. If fluid enters skin or eyes, get immediate medical attention from a physician familiar with this injury.

W-2072-0807

Figure 36

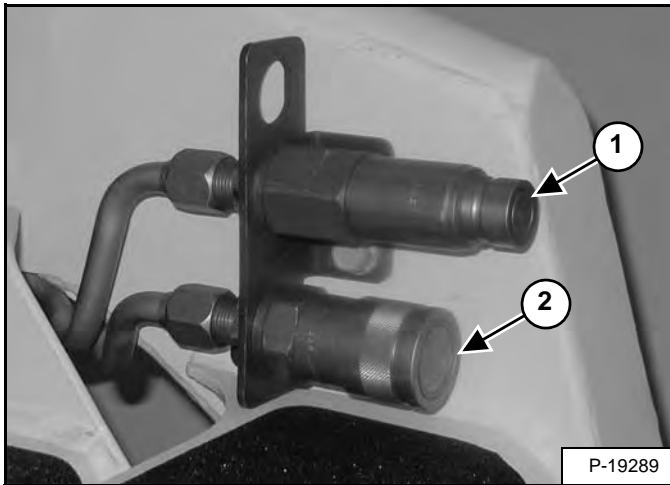

**To Connect:** Remove dirt or debris from the surface of both the male (Item 1) and female couplers (Item 2) [Figure 36], and from the outside diameter of the male coupler. Visually check the couplers for corroding, cracking, damage or excessive wear. If any of these conditions exist, the coupler(s) must be replaced.

Install the male coupler into the female coupler. Full connection is made when the ball release sleeve slides forward on the female coupler.

**To Disconnect:** Hold the male coupler. Retract the sleeve on the female coupler until the couplers disconnect.

### Relieve Auxiliary Hydraulic Pressure (Loader And Attachment)

Hydraulic pressure in the auxiliary hydraulic system can make it difficult to engage quick couplers to an attachment.

*Loader:*

1. Turn the key to the ON position or press RUN button but do not start the engine. Press the PRESS TO OPERATE LOADER Button.

Figure 37



2. Move the Auxiliary Hydraulic Control Lever (Item 1) [Figure 37] left and right to release auxiliary hydraulic oil pressure. Turn key to OFF position or press STOP button.

*Attachments:*

1. Follow procedure above to release pressure in the loader.
2. Connect male coupler from attachment to female coupler of the loader then repeat procedure above. This will release pressure in the attachment.
3. Connect the female coupler from the attachment to the male coupler of the loader.

## ATTACHMENT CONTROL DEVICE (ACD)

This machine may be equipped with an Attachment Control Device.

### Description

Figure 38

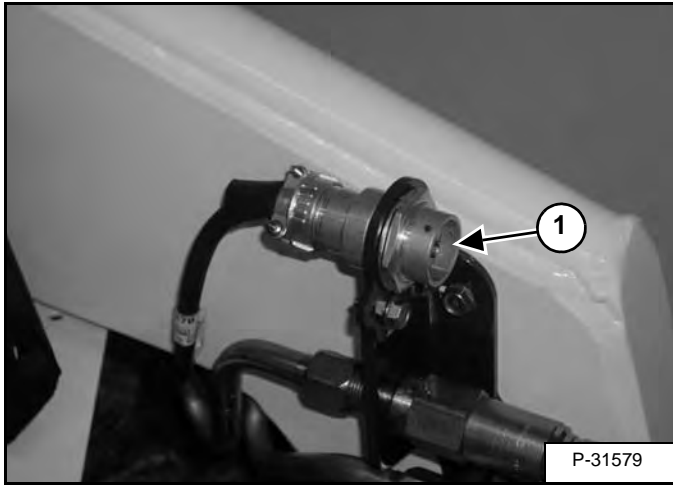

Connect the attachment electrical harness to the attachment control device (Item 1) [Figure 38].

Figure 39

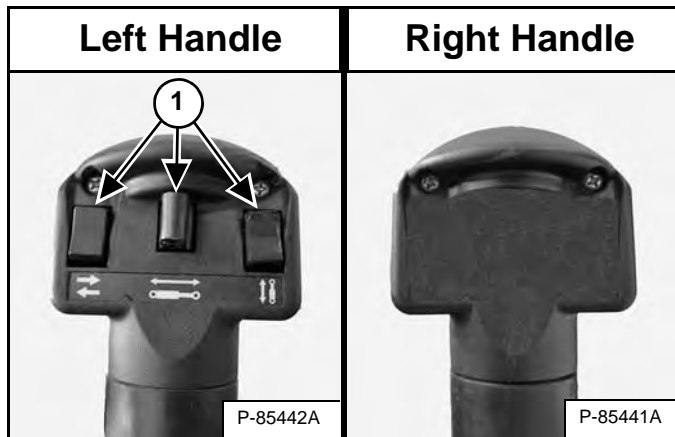

Additional switches (Item 1) [Figure 39] on the left steering lever handle are used to control some attachment functions through the attachment control device.

See the appropriate attachment Operation & Maintenance Manual for control details.

Figure 40

### SERVICE CHECKLIST AND SCHEDULE

**EVERY 10 HRS (BEFORE STARTING THE LOADER)**

- ENGINE OIL & FILTER - Check level and add as needed. Do not overfill. Change oil and filter after first 50 Hrs. then refer to Operation & Maintenance Manual for proper change interval for your Model.
- ENGINE AIR FILTER - Check condition indicator and/ or display. Service only when required. Do not use compressed air to clean elements.
- ENGINE AIR SYSTEM - Check for leaks and damaged components.
- ENGINE COOLING SYSTEM - Clean debris from grill, oil cooler and radiator. Check coolant level cold; add coolant mixture if required.
- FUEL FILTER - Remove trapped water.
- LOADER LIFT ARMS, LIFT LINKS, CYLINDERS, BOB-TACH PIVOT & WEDGES, STEERING CYLINDERS (AWS Machines Only) - Lubricate with multipurpose lithium based grease.
- SEAT BELT, SEAT BAR AND CONTROL INTERLOCKS - Check function. Repair or replace as needed. Clean dirt and debris from moving parts.
- BICS - Check for correct function. Clean dirt and debris from moving parts. Lift and Tilt functions MUST NOT operate with seat bar raised.
- TIRES - Check air pressure. Inflate to MAXIMUM pressure shown on sidewall of tire.
- GENERAL - Check for loose or broken parts, damaged operator cab, instrument operation, loose wheel nuts or track sprocket nuts, oil leaks, damaged or missing safety signs (decals).

**EVERY 50 HRS**

- HYDRAULIC FLUID, HOSES AND TUBELINES - Check fluid level and add if required. Check for damage and for leaks. Repair or replace as needed.
- FINAL DRIVE TRANSMISSION (CHAINCASE, Wheel Machines Only) - Check fluid level and add if required.
- HYDRAULIC & STEERING CONTROLS (PEDALS, HAND, and/ or JOYSTICK) - Check for correct operation. Adjust as needed.
- WHEEL NUTS / TRACK DRIVE SPROCKETS - Check for loose nuts and tighten as needed.
- TRACK TENSION (Track Machines Only) - Check tension and adjust as needed.

**EVERY 100 HRS**

- SPARK ARRESTOR MUFFLER - Empty spark chamber. (If equipped.)
- BATTERY - Check battery for damage, hold down clamps, cables, connections and electrolyte level. Add distilled water as needed.
- DRIVE LINE - Lubricate Engine-to-Pump Coupler with multipurpose lithium based grease. (If equipped.)

**EVERY 250 HRS**

- STEERING LEVER PIVOTS - Lubricate with multipurpose lithium based grease. (If equipped.)
- FUEL FILTER - Replace filter.
- KING PINS (AWS Machines Only) - Lubricate with multipurpose lithium based grease.
- ENGINE / HYDRAULIC DRIVE BELT - Check for wear or damage. Adjust or replace as needed. (If equipped.)
- FAN DRIVE GEARBOX - Check fluid level and add if required. (If equipped.)
- OTHER DRIVE BELTS (Hydrostatic pump, water pump, alternator, and air conditioner - If equipped.) - Check condition and tension. Adjust or replace as needed.
- BICS - Check function of Lift Arm By-Pass control.

**EVERY 500 HRS**

- FAN / HYDRAULIC / HYDROSTATIC SYSTEM - Replace filter. Replace reservoir breather cap.
- STEERING VALVE INLINE FILTER (AWS Only) - Replace filter.
- HYDROSTATIC MOTOR CARRIER (Track Machines Only) - Replace oil.

**EVERY 1000 HRS**

- HYDRAULIC RESERVOIR - Replace fluid.
- FINAL DRIVE TRANSMISSION (Chaincase on Wheel Machines Only) - Replace fluid.
- TRACK ROLLER, IDLER ASSEMBLIES (Track Machines Only) - Replace fluid (If required).
- DRIVE MOTOR CASE DRAIN FILTER - Replace filter. (If equipped.)
- WHEEL BEARING & OUTER SPLINES (AWS only) - Repack wheel bearings, grease internal splines in hub yoke. (Dealer Service Only)

**NOTES:**

- Replace element sooner if transmission warning indicator remains on for more than 5 minutes after hydraulic fluid is at operating temperature.
- Service at first 50 Hours, then as scheduled.
- See Operation & Maintenance Manual for correct fluid specifications, filter part number and location, and appropriate service interval for your Model.

### GENERAL LUBRICATION DIAGRAMS

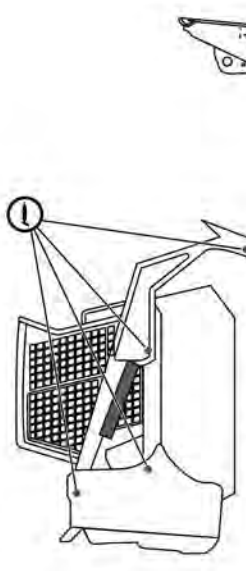

**RADIUS PATH MACHINE**

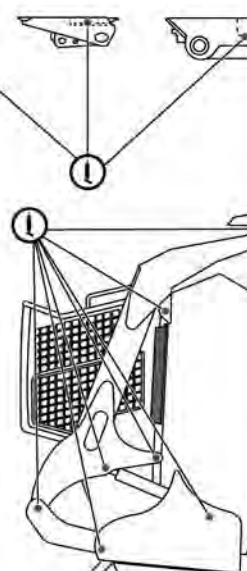

**VERTICAL PATH MACHINE**

● TYPICAL GREASE POINTS



**BE PARTS & SERVICE SMART**  
Use Genuine Bobcat Replacement Parts

### WARNING

#### AVOID INJURY OR DEATH

- Keep door closed except for service.
- Keep engine clean of flammable material.
- Keep body, loose objects and clothing away from electrical contacts, moving parts, hot parts and exhaust.
- Do not use loader in space with explosive dusts or gases or with flammable material near exhaust.
- Never use ether or starting fluid on diesel engine with glow plugs. Use only starting aids as approved by engine manufacturer.
- Leaking fluids under pressure can enter skin and cause serious injury.
- Battery acid causes severe burns; wear goggles. If acid contacts eyes, skin, or clothing, flush with water. For contact with eyes, flush and get medical attention.
- Battery makes flammable and explosive gas. Keep arcs, sparks, flames and lighted tobacco away.
- For jump start, connect negative cable to loader engine last (never at the battery). After jump start, remove negative connection at the engine first.
- Exhaust gases can kill. Always ventilate.

### SEE OPERATION & MAINTENANCE MANUAL FOR MORE INFORMATION AND INSTRUCTIONS.

73094 SW 6724534E enUS

## DAILY INSPECTION (CONT'D)

### Daily Inspection And Maintenance

Maintenance work must be done at regular intervals. Failure to do so will result in excessive wear and early failures. The Service Schedule [Figure 40] is a guide for correct maintenance of the Bobcat Loader. It is located inside the rear door of the loader and also in the MACHINE SIGN TRANSLATION section of this manual. (See Service Schedule (6734534) on Page 117.)

- Engine oil level.
- Hydraulic / hydrostatic fluid level.
- Engine Air Filter - Check Air System for Damage or Leaks.
- Engine coolant system - check system for damage or leaks.
- Operator cab and cab mounting hardware.
- Seat belt.
- Seat Bar and Control interlocks.
- Bobcat Interlock Control System (BICS™).
- Front Horn and Back-up Alarm - Check for proper function.
- Grease Pivot Pins (Lift Arms, Bob-Tach, Cylinders, Bob-Tach Wedges).
- Tires - Check for Wear, Damage, Correct Air Pressure.
- Fuel Filter - Remove Trapped Water.
- Loose or Broken Parts - Repair or Replace as Necessary.
- Safety Treads and Safety Signs (Decals) - Replace as necessary.
- Lift Arm Support Device - Replace if damaged.
- Indicators and Lights.
- Clean Foot Pedal Area.
- Monitor Instrument Panel for fuel level, coolant temperature and air cleaner condition.

## WARNING

**Operator must have instructions before operating the machine. Untrained operators can cause injury or death.**

W-2001-0502

**NOTE: Fluids such as engine oil, hydraulic fluid, coolant, etc. must be disposed of in an environmentally safe manner. Some regulations require that certain spills and leaks on the ground must be cleaned in a specific manner. See local, state and federal regulations for correct disposal.**

## IMPORTANT

### PRESSURE WASHING DECALS

- **Never direct the stream at a low angle toward the decal that could damage the decal causing it to peel from the surface.**
- **Direct the stream at a 90 degree angle and at least 300 mm (12 in) from the decal. Wash from the center of the decal toward the edges.**

I-2226-0910

## PRE-STARTING PROCEDURE

### Entering The Loader

Figure 41



Use the bucket or attachment steps, grab handles, and safety treads (on the loader lift arms and frame) to get on and off the loader, maintaining a 3-point contact at all times **[Figure 41]**. DO NOT JUMP!

Safety treads are installed on the Bobcat Loader to provide a slip resistant surface for getting on and off the loader.

Keep the safety treads clean and replace them when damaged. Replacement treads are available from your Bobcat dealer.

### Operation & Maintenance Manual And Operator's Handbook Locations

Figure 42

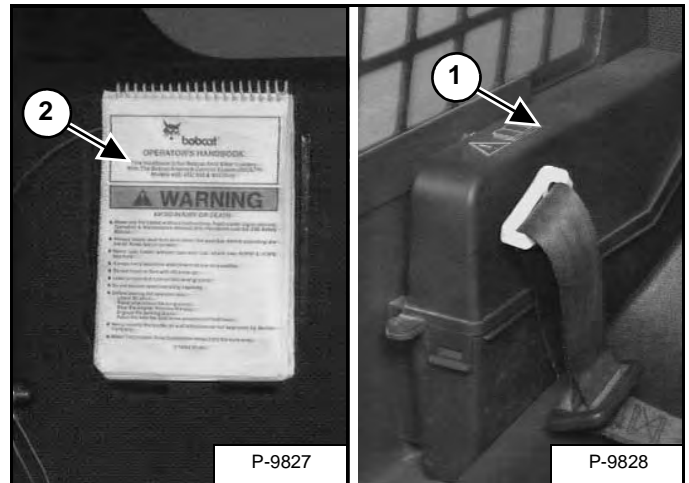

Read and understand the Operation & Maintenance Manual (Item 1) and the Operator's Handbook (Item 2) **[Figure 42]** before operating the loader.

The Operation & Maintenance Manual and other manuals can be kept in a container (Item 1) **[Figure 42]** provided on the right side of the operator seat.



#### AVOID INJURY OR DEATH

Instructions are necessary before operating or servicing machine. Read and understand the Operation & Maintenance Manual, Operator's Handbook and signs (decals) on machine. Follow warnings and instructions in the manuals when making repairs, adjustments or servicing. Check for correct function after adjustments, repairs or service. Untrained operators and failure to follow instructions can cause injury or death.

W-2003-0807

## PRE-STARTING PROCEDURE (CONT'D)

### Seat Adjustment

#### Standard Seat

Figure 43

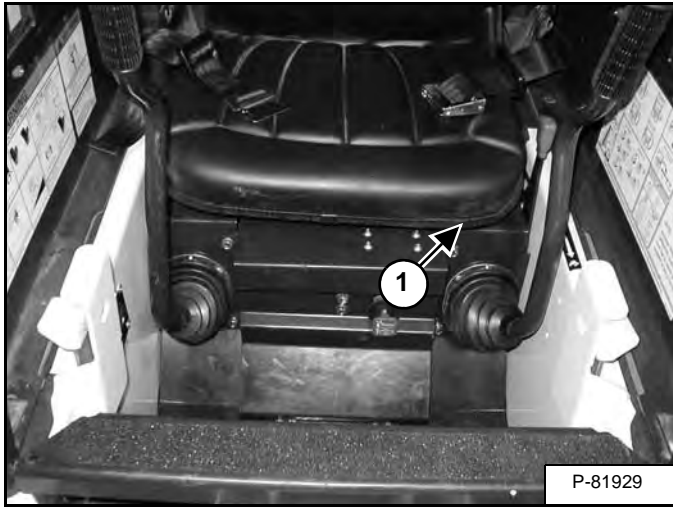

Use the lever (Item 1) [Figure 43] to adjust the position of the seat for comfortable operation of the loader controls.

#### Adjustable Cushion Seat

Figure 44

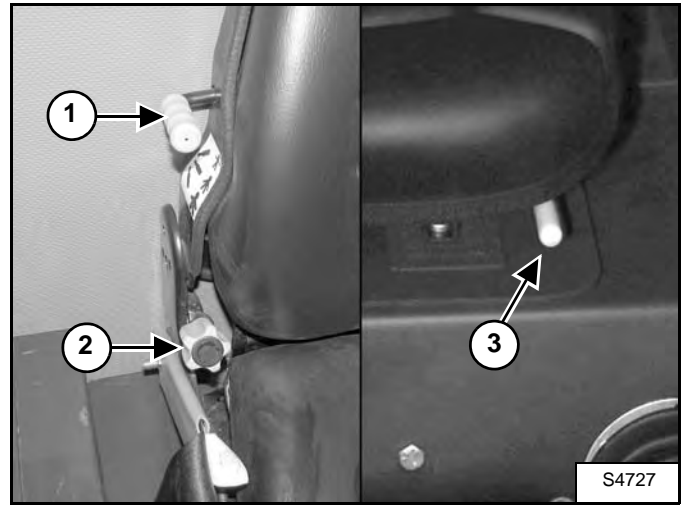

Use the lever (Item 1) and knob (Item 2) [Figure 44] to adjust the position of the seat for comfortable operation of the loader controls.

The lever (Item 1) sets the seat cushion for the weight of the operator. The knob (Item 2) [Figure 44] sets the angle of the seat back.

The lever (Item 3) [Figure 44] adjusts the fore / aft position of the seat.



## PRE-STARTING PROCEDURE (CONT'D)

### Seat Belt Adjustment



#### AVOID INJURY OR DEATH

When operating the machine:

- Keep the seat belt fastened snugly.
- The seat bar must be lowered.
- Keep your feet on the pedal controls and hands on steering levers.

W-2046-0108

Figure 45

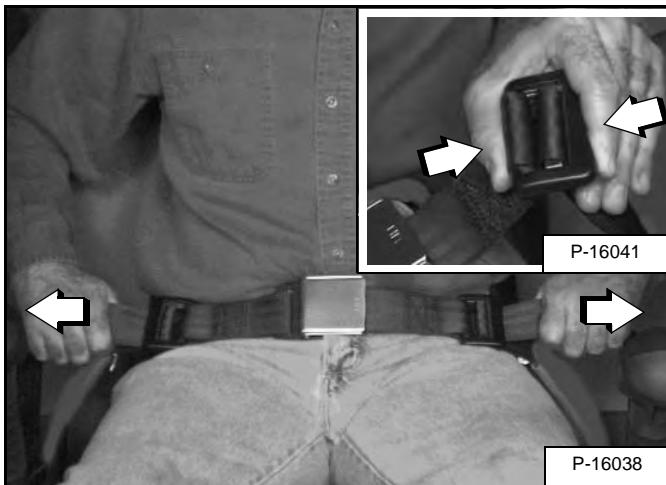

Squeeze both seat belt adjusters to release and lengthen each half of the seat belt [Figure 45].

Fasten the seat belt.

Pull the ends of the belt through the belt adjusters so that the seat belt is snug and the buckle is centered between your hips [Figure 45].

### Seat Bar

Figure 46

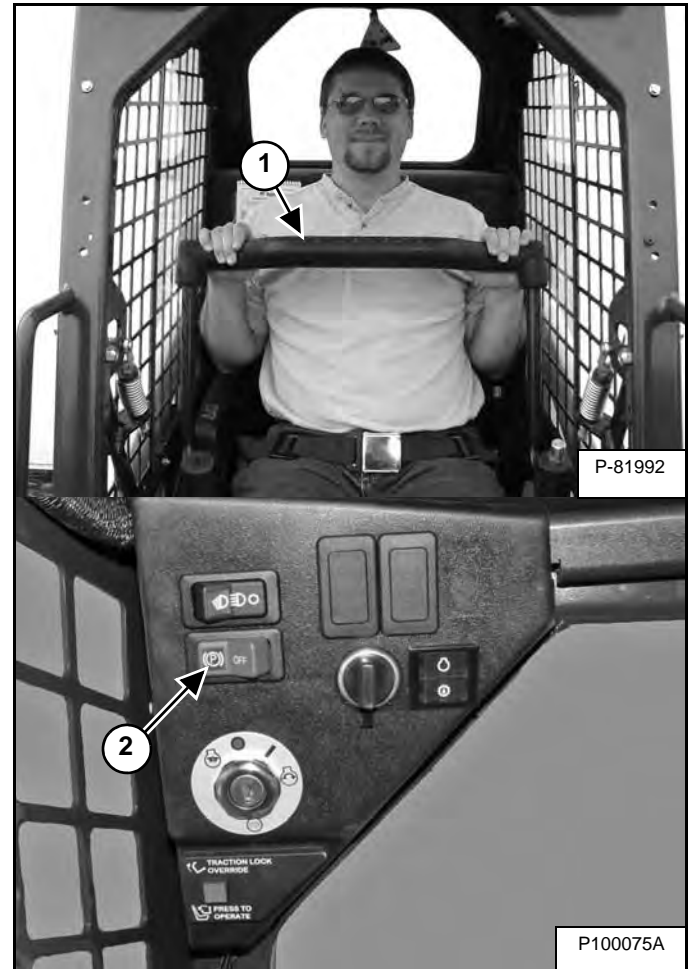

Lower the seat bar (Item 1) and engage the parking brake (Item 2) [Figure 46].

Put the foot pedals and steering levers in neutral position.

**NOTE: Keep your hands on the steering levers and your feet on the foot pedals while operating the loader.**



#### AVOID INJURY OR DEATH

When operating the machine:

- Keep the seat belt fastened snugly.
- The seat bar must be lowered.
- Keep your feet on the pedal controls and hands on steering levers.

W-2046-0108

## STARTING THE ENGINE

### Standard Key Panel

# ! WARNING

#### AVOID SERIOUS INJURY OR DEATH

- Engines can have hot parts and hot exhaust gas. Keep flammable material away.
- Do not use machines in atmosphere containing explosive dust or gases.

W-2051-0212

Perform the PRE-STARTING PROCEDURE. (See PRE-STARTING PROCEDURE on Page 45.)

Figure 47

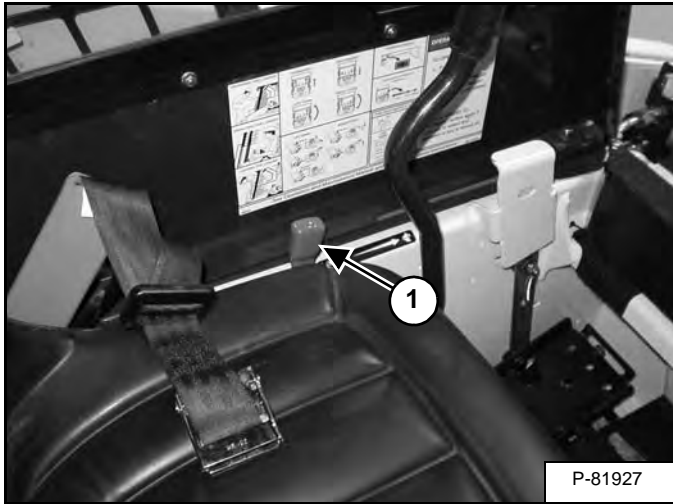

Move the engine speed control lever (Item 1) [Figure 47] to the mid position.

# ! WARNING

#### AVOID INJURY OR DEATH

- Fasten seat belt, start and operate only from the operator's seat.
- Never wear loose clothing when working near machine.

W-2135-1108

Figure 48

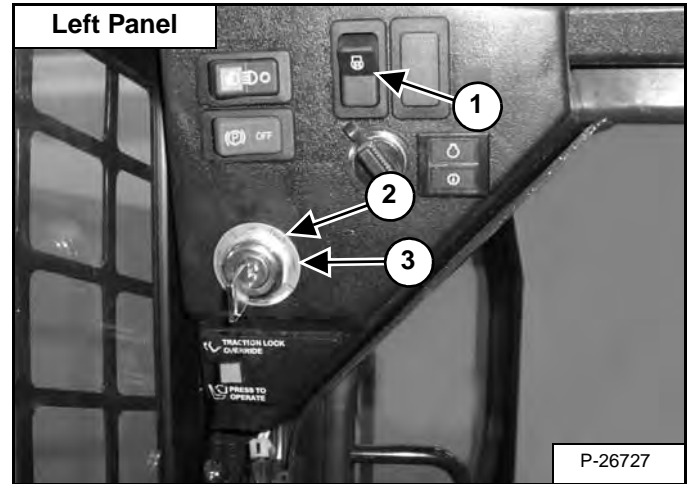

Earlier Models With Preheat Switch (Item 1)

If the temperature is cold, turn the key switch to the RUN position (Item 2) [Figure 48] but do not start the engine.

Press and hold the top of the preheat switch (Item 1) [Figure 48]. Release the switch to stop engine preheat. A decal in the operator cab and the table below show suggested preheat times.

AMBIENT AIR TEMPERATURE	PREHEAT TIME
21°C and Above (70°F and Above)	None Required
10 - 21°C (50 - 70°F)	5 Seconds
-18 - 10°C (0 - 50°F)	15 Seconds
-18°C and Below (0°F and Below)	25 Seconds

**NOTE: You can hold the preheat switch for up to 25 seconds at a time while cranking.**

Turn the key switch to the START position (Item 3) [Figure 48] and continue to crank for up to one minute or until the engine starts.

Release the key when the engine starts. It will return to the RUN position (Item 2) [Figure 48].

## STARTING THE ENGINE (CONT'D)

### Standard Key Panel (Cont'd)

Figure 49

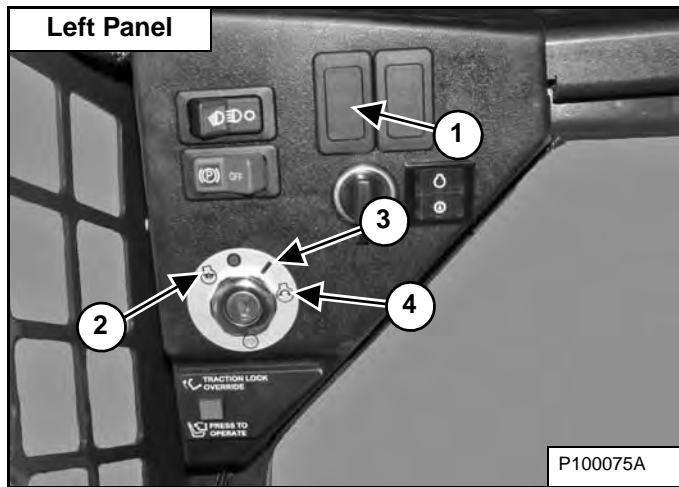

#### Later Models Without Preheat Switch (Item 1)

If the temperature is cold, turn the key switch to the PREHEAT position (Item 2) [Figure 49].

Release the key switch to stop engine preheat. A decal in the operator cab and the table below show suggested preheat times.

AMBIENT AIR TEMPERATURE	PREHEAT TIME
21°C and Above (70°F and Above)	None Required
10 - 21°C (50 - 70°F)	5 Seconds
-18 - 10°C (0 - 50°F)	15 Seconds
-18°C and Below (0°F and Below)	25 Seconds

Turn the key switch to the START position (Item 4) [Figure 49] and continue to crank for up to one minute or until the engine starts.

Release the key when the engine starts. It will return to the RUN position (Item 3) [Figure 49].

All Models

Figure 50

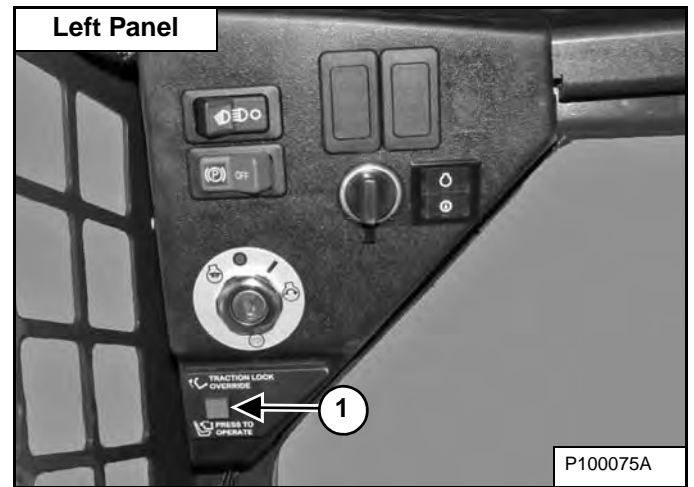
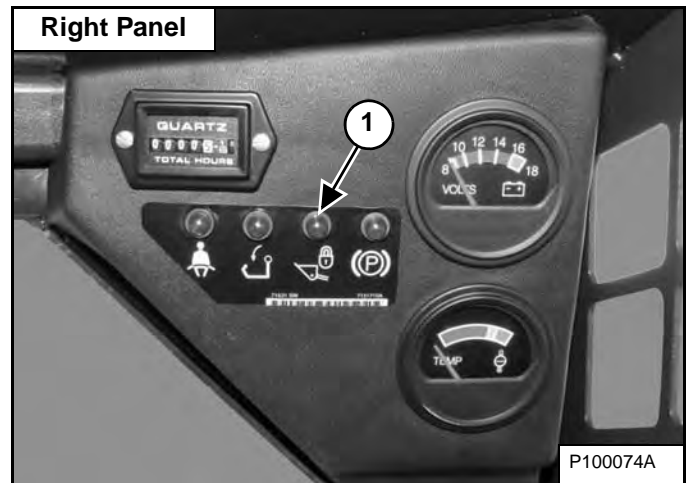

Figure 51



Press the PRESS TO OPERATE LOADER button (Item 1) [Figure 50] to activate the BICS™ and to perform hydraulic and loader functions. The Lift & Tilt Valve light (Item 1) [Figure 51] will be OFF when the BICS™ is active.

## WARNING

### AVOID INJURY OR DEATH

When an engine is running in an enclosed area, fresh air must be added to avoid concentration of exhaust fumes. If the engine is stationary, vent the exhaust outside. Exhaust fumes contain odorless, invisible gases which can kill without warning.

W-2050-0807

## STARTING THE ENGINE (CONT'D)

### Keyless Start Panel

# ! WARNING

#### AVOID SERIOUS INJURY OR DEATH

- Engines can have hot parts and hot exhaust gas. Keep flammable material away.
- Do not use machines in atmosphere containing explosive dust or gases.

W-2051-0212

Perform the PRE-STARTING PROCEDURE. (See PRE-STARTING PROCEDURE on Page 45.)

Figure 52

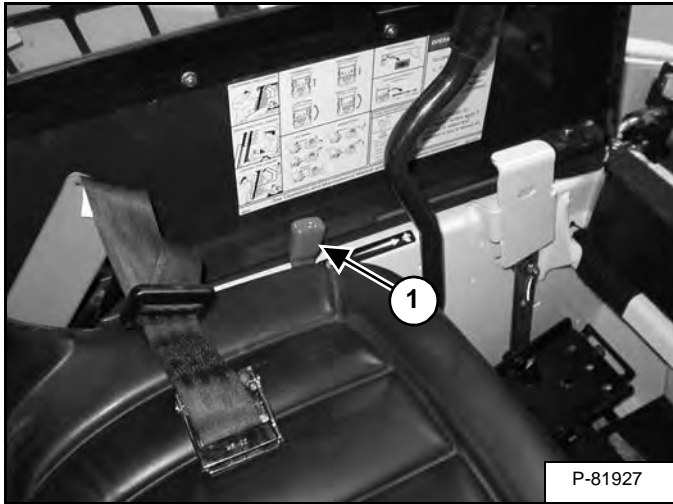

Move the engine speed control lever (Item 1) [Figure 52] to the mid position.

# ! WARNING

#### AVOID INJURY OR DEATH

- Fasten seat belt, start and operate only from the operator's seat.
- Never wear loose clothing when working near machine.

W-2135-1108

Figure 53

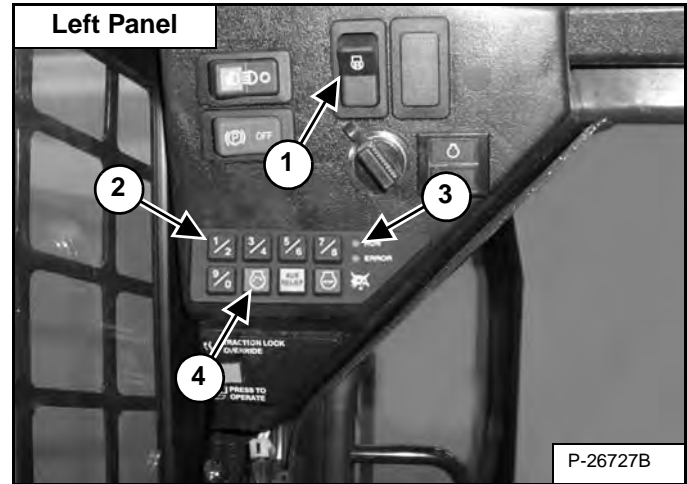

Earlier Models With Preheat Switch (Item 1)

Enter the password / user code on the keypad (Item 2), the RUN light (Item 3) [Figure 53] will illuminate.

If the temperature is cold, press and hold the top of the preheat switch (Item 1) [Figure 53]. Release the switch to stop engine preheat.

A decal in the operator cab and the table below show suggested preheat times.

AMBIENT AIR TEMPERATURE	PREHEAT TIME
21°C and Above (70°F and Above)	None Required
10 - 21°C (50 - 70°F)	5 Seconds
-18 - 10°C (0 - 50°F)	15 Seconds
-18°C and Below (0°F and Below)	25 Seconds

**NOTE:** You can hold the preheat switch for up to 25 seconds at a time while cranking.

Press the start button (Item 4) [Figure 53] and continue to crank for up to one minute or until the engine starts.

Release the start button when the engine starts.

## STARTING THE ENGINE (CONT'D)

### Keyless Start Panel (Cont'd)

Figure 54

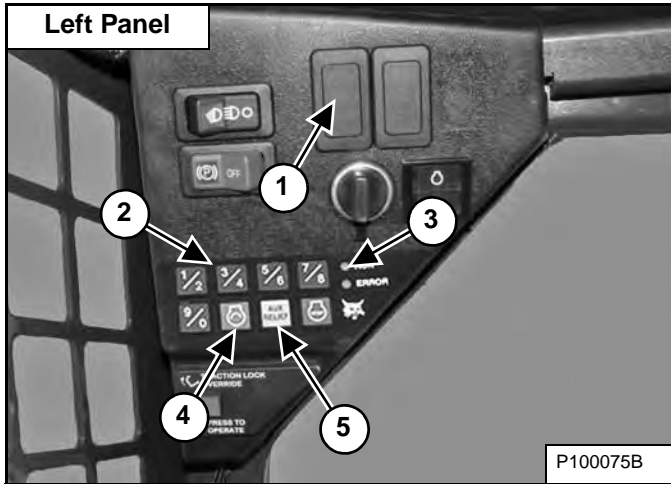

Later Models Without Preheat Switch (Item 1)

Enter the password / user code on the keypad (Item 2), the RUN light (Item 3) [Figure 54] will illuminate.

If the temperature is cold, press and hold the AUX. RELIEF / Preheat button (Item 5) [Figure 54]. Release the button to stop engine preheat.

A decal in the operator cab and the table below show suggested preheat times.

AMBIENT AIR TEMPERATURE	PREHEAT TIME
21°C and Above (70°F and Above)	None Required
10 - 21°C (50 - 70°F)	5 Seconds
-18 - 10°C (0 - 50°F)	15 Seconds
-18°C and Below (0°F and Below)	25 Seconds

**NOTE:** You can hold the AUX. RELIEF / Preheat button for up to 25 seconds at a time while cranking.

Press the start button (Item 4) [Figure 54] and continue to crank for up to one minute or until the engine starts.

Release the start button when the engine starts.

All Models

Figure 55

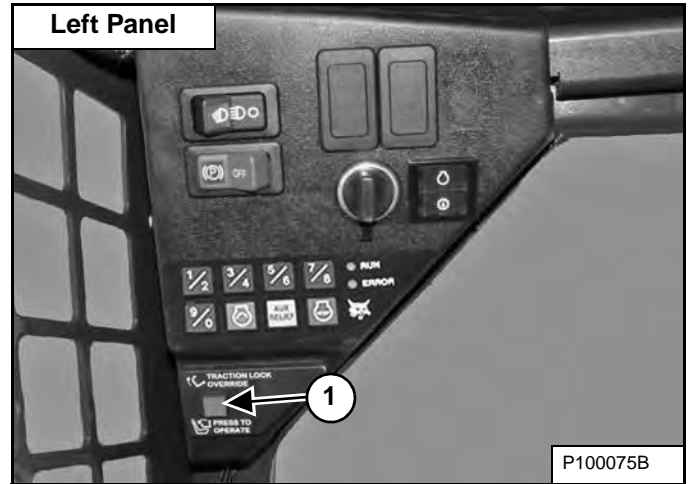
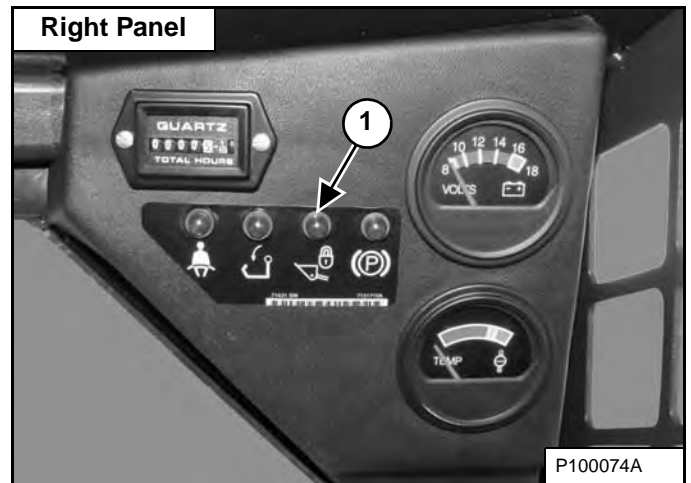

Figure 56



Press the PRESS TO OPERATE LOADER button (Item 1) [Figure 55] to activate the BICS™ and to perform hydraulic and loader functions. The Lift & Tilt Valve light (Item 1) [Figure 56] will be OFF when the BICS™ is active.

**! WARNING**

**AVOID INJURY OR DEATH**

When an engine is running in an enclosed area, fresh air must be added to avoid concentration of exhaust fumes. If the engine is stationary, vent the exhaust outside. Exhaust fumes contain odorless, invisible gases which can kill without warning.

W-2050-0807

## STARTING THE ENGINE (CONT'D)

### Cold Temperature Starting

# ! WARNING

### AVOID INJURY OR DEATH

Do not use ether with glow plug (preheat) systems. Explosion can result which can cause injury, death, or severe engine damage.

W-2071-0907

If the temperature is below freezing perform the following to make starting the engine easier:

- Replace the engine oil with the correct type and viscosity for the anticipated starting temperature (See Engine Oil Chart on Page 88.)
- Make sure the battery is fully charged.
- Install an engine heater, available from your local Bobcat dealer.

### Warming The Hydraulic / Hydrostatic System

# IMPORTANT

When the temperature is below  $-30^{\circ}\text{C}$  ( $-20^{\circ}\text{F}$ ), hydrostatic oil must be warmed before starting. The hydrostatic system will not get enough oil at low temperatures and will be damaged. Park the machine in an area where the temperature will be above  $-18^{\circ}\text{C}$  ( $0^{\circ}\text{F}$ ) if possible.

I-2007-0910

Let the engine run for a minimum of 5 minutes to warm the engine and hydrostatic transmission fluid before operating the loader.

## MONITORING THE DISPLAY PANELS

### Right Panel

Figure 57

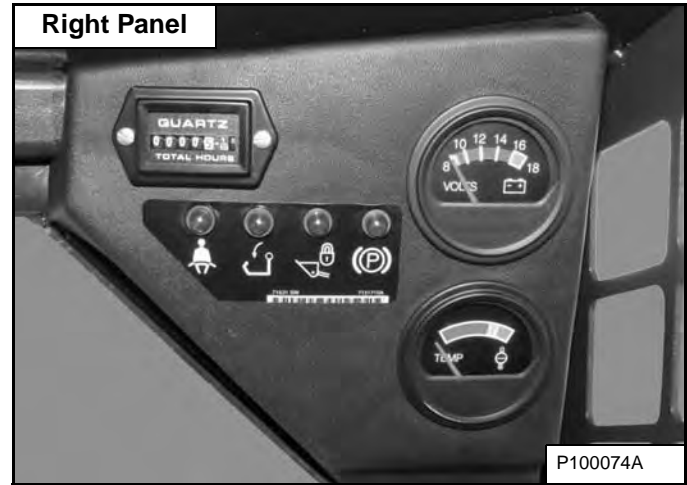

Frequently monitor the temperature gauge and BICS™ lights [Figure 57]. All BICS™ lights must be off to operate the loader. (See BOBCAT INTERLOCK CONTROL SYSTEM (BICS™) on Page 72.)

## STOPPING THE ENGINE AND LEAVING THE LOADER

### Procedure

Stop the Bobcat Loader on level ground.

Lower the lift arms fully and put the attachment flat on the ground.

**Figure 58**

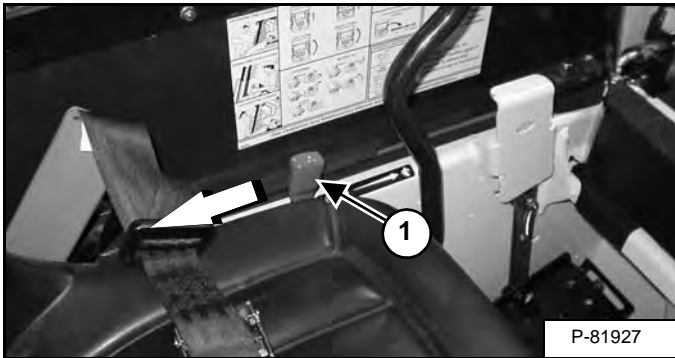

Pull the engine speed control lever (Item 1) [Figure 58] fully backward to decrease the engine speed.

**Figure 59**

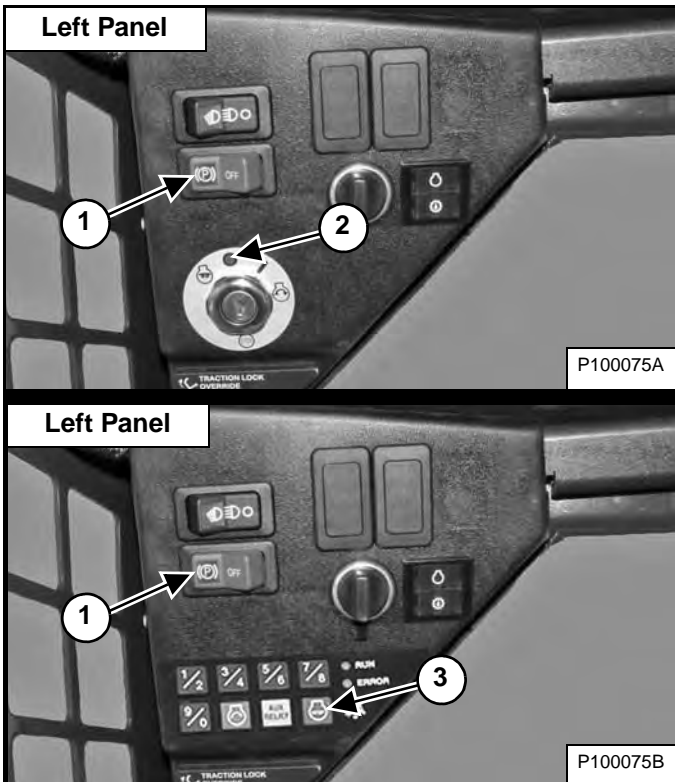

Turn the key switch to the OFF position (Item 2) or press the STOP button (Item 3) [Figure 59].

Engage the parking brake by pressing the left side of the parking brake switch (Item 1) [Figure 59].

Raise the seat bar and make sure the lift and tilt functions are deactivated. Move the pedals until they both lock.

Move auxiliary hydraulic control lever out of detent position.

Unbuckle the seat belt.

Remove the key from the switch to prevent operation of the loader by unauthorized personnel. (Standard Key Panel only.)

**Figure 60**



Exit the loader using grab handles, safety tread and steps (maintaining a 3-point contact) [Figure 60].



**Before you leave the operator's seat:**

- Lower the lift arms, put the attachment flat on the ground.
- Stop the engine.
- Engage the parking brake.
- Raise the seat bar, move pedals until both lock.
- Move auxiliary hydraulic control lever out of detent position.

W-2164-0108

## ATTACHMENTS

### Choosing The Correct Bucket

# ! WARNING

## AVOID INJURY OR DEATH

Never use attachments or buckets which are not approved by Bobcat Company. Buckets and attachments for safe loads of specified densities are approved for each model. Unapproved attachments can cause injury or death.

W-2052-0907

**NOTE: Warranty is void if non-approved attachments are used on the Bobcat Loader.**

The dealer can identify, for each model loader, the attachments and buckets approved by Bobcat. The buckets and attachments are approved for Rated Operating Capacity (ROC) and for secure fastening to the Bob-Tach.

The ROC for this loader is shown on a decal in the operator cab. (See Performance on Page 130.)

The ROC is determined by using a standard bucket, and material of normal density, such as dirt or dry gravel. If longer buckets are used, the load center moves forward and reduces the ROC. If very dense material is loaded, the volume must be reduced to prevent overloading.

Figure 61

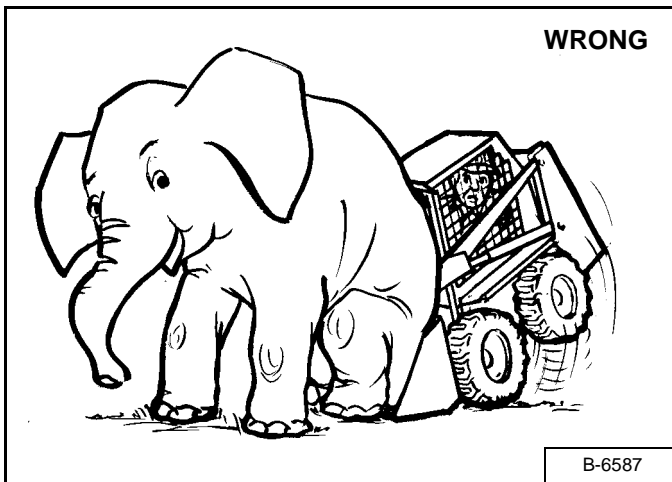

Exceeding the ROC [Figure 61] can cause the following problems:

- Steering the loader may be difficult.
- Tires will wear faster.
- There will be a loss of stability.
- The life of the Bobcat Loader will be reduced.

Use the correct bucket size for the type and density of material being handled. For safe handling of materials and avoiding machine damage, the attachment (or bucket) should handle a full load without going over the ROC for the loader. Partial loads make steering more difficult.

### Pallet Forks

Figure 62

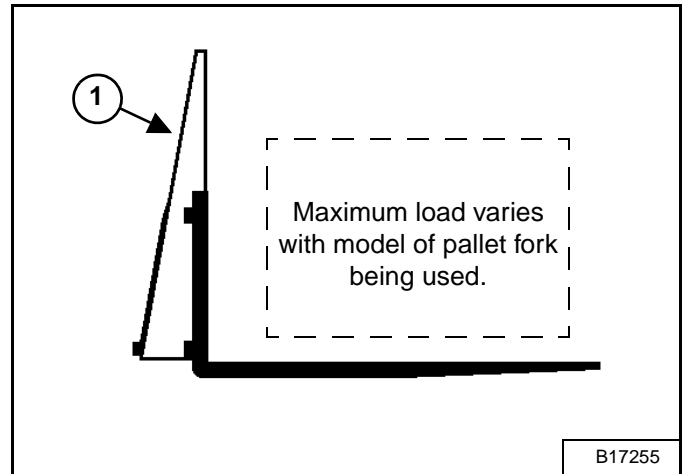

The maximum load to be carried when using a pallet fork is shown on a decal located on the pallet fork frame (Item 1) [Figure 62].

See your Bobcat dealer for more information about pallet fork inspection, maintenance and replacement. See your Bobcat Loader dealer for ROC when using a pallet fork and for other available attachments.

# ! WARNING

## AVOID INJURY OR DEATH

Do not exceed Rated Operating Capacity (ROC). Excessive load can cause tipping or loss of control.

W-2053-0903



## ATTACHMENTS (CONT'D)

### Installing And Removing The Attachment

The Bob-Tach is used for fast changing of buckets and attachments. See the appropriate attachment Operation & Maintenance Manual to install other attachments.

#### Installing

Figure 63

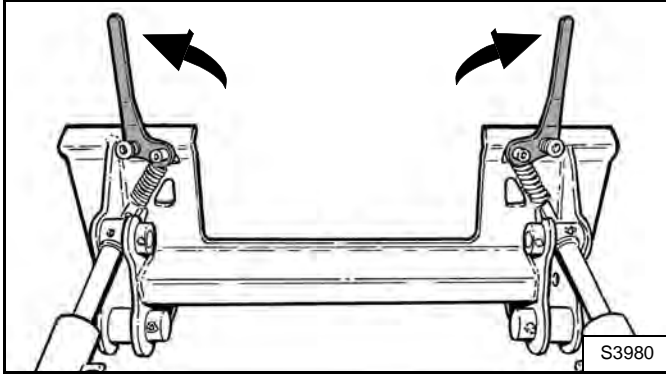

Pull the Bob-Tach levers all the way up [Figure 63].

Enter the loader and perform the PRE-STARTING PROCEDURE. (See PRE-STARTING PROCEDURE on Page 45.) Start the engine.

Lower the lift arms and tilt the Bob-Tach slightly forward.

Figure 64

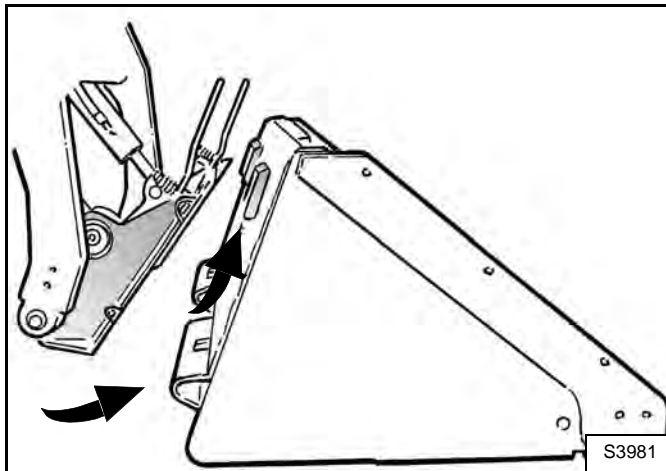

Disengage the parking brake and drive the loader forward until the top edge of the Bob-Tach is completely under the top flange of the bucket [Figure 64] (or other attachment).

**NOTE:** Make sure the Bob-Tach levers do not hit the bucket (or other attachment).

Figure 65

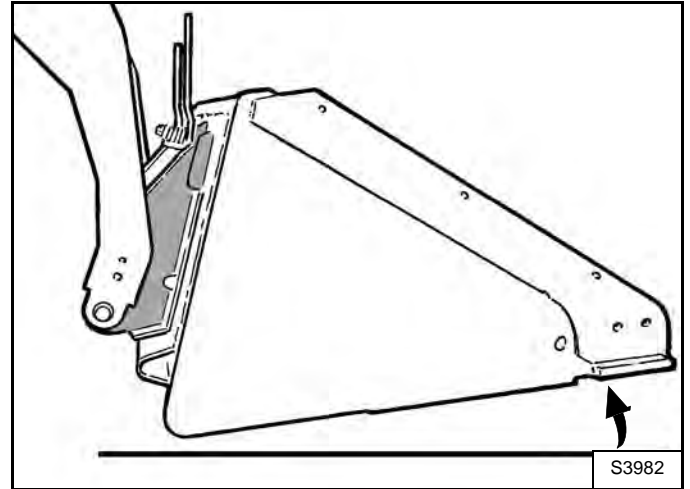

Tilt the Bob-Tach backward until the cutting edge of the bucket (or other attachment) is slightly off the ground [Figure 65]. This will cause the bucket frame to fit up against the front of the Bob-Tach.

## **WARNING**

Before you leave the operator's seat:

- Lower the lift arms, put the attachment flat on the ground.
- Stop the engine.
- Engage the parking brake.
- Raise the seat bar, move pedals until both lock.
- Move auxiliary hydraulic control lever out of detent position.

W-2164-0108

Stop the engine, engage the parking brake, raise the seat bar, unfasten the seat belt and exit the loader.

## ATTACHMENTS (CONT'D)

### Installing And Removing The Attachment (Cont'd)

*Installing (Cont'd)*

**Figure 66**

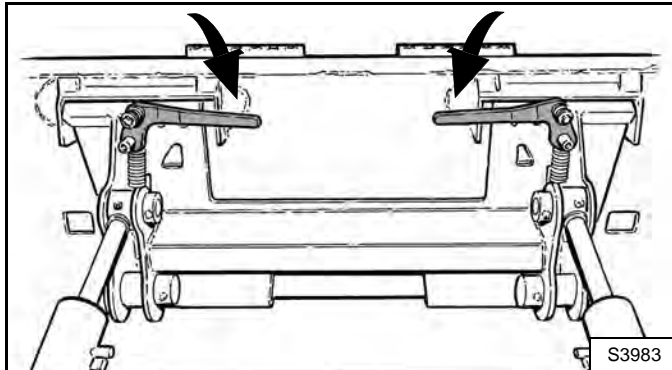

Push down on the Bob-Tach levers until they are fully engaged in the locked position [Figure 66].

**Figure 67**

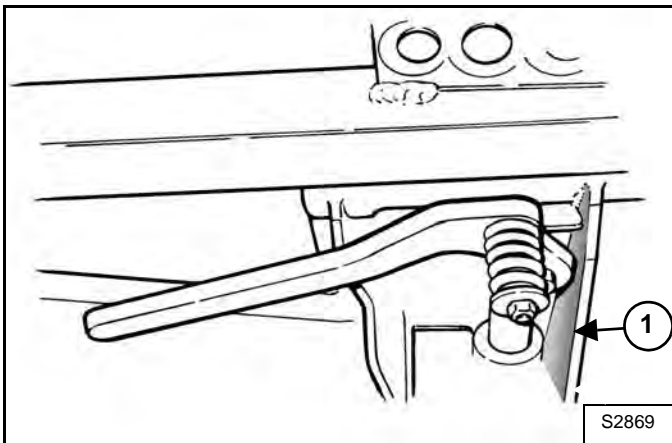

The levers must contact the frame at the shaded areas (Item 1) [Figure 67] (wedges fully extended).

If the levers do not engage in the locked position, contact your Bobcat dealer for maintenance.

**Figure 68**

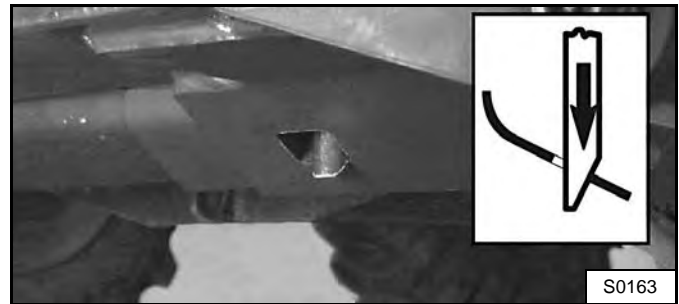

The wedges must extend through the holes in the mounting frame of the bucket (or attachment) and touch the lower edge of these holes, securely fastening the bucket to the Bob-Tach [Figure 68].

## **WARNING**

### **AVOID INJURY OR DEATH**

**The Bob-Tach wedges must extend through the holes in the attachment mounting frame. Levers must be fully down and locked. Failure to secure wedges can allow attachment to come off.**

W-2715-0208

If the attachment is hydraulically controlled, connect the hydraulic hoses of the attachment to the loader (See Quick Couplers on Page 41.) You may need to release hydraulic pressure before connecting the quick couplers. (See Relieve Auxiliary Hydraulic Pressure (Loader And Attachment) on Page 41.)

## ATTACHMENTS (CONT'D)

### Installing And Removing The Attachment (Cont'd)

#### Removing

- Lower the lift arms, put the attachment flat on the ground and lower or close the hydraulic equipment.
- If the attachment is hydraulically controlled (Combination bucket, backhoe, etc.): stop the engine and relieve hydraulic pressure in the auxiliary circuit (See Relieve Auxiliary Hydraulic Pressure (Loader And Attachment) on Page 41.)
- Stop the engine, engage the parking brake, raise the seat bar, unfasten the seat belt and exit the loader.
- Disconnect the hydraulic hoses from the attachment.

## ! WARNING

Before you leave the operator's seat:

- Lower the lift arms, put the attachment flat on the ground.
- Stop the engine.
- Engage the parking brake.
- Raise the seat bar, move pedals until both lock.
- Move auxiliary hydraulic control lever out of detent position.

W-2164-0108

Figure 69

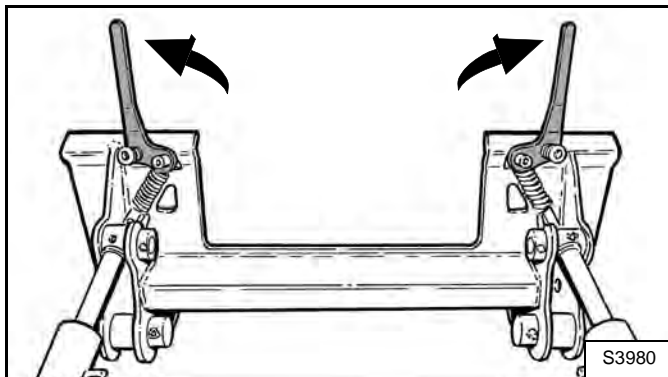

Pull the Bob-Tach levers all the way up [Figure 69].

## ! WARNING

Bob-Tach levers have spring tension. Hold lever tightly and release slowly. Failure to obey warning can cause injury.

W-2054-1285

Enter the loader and perform the PRE-STARTING PROCEDURE. (See PRE-STARTING PROCEDURE on Page 45.) Start the engine and disengage the parking brake.

Figure 70

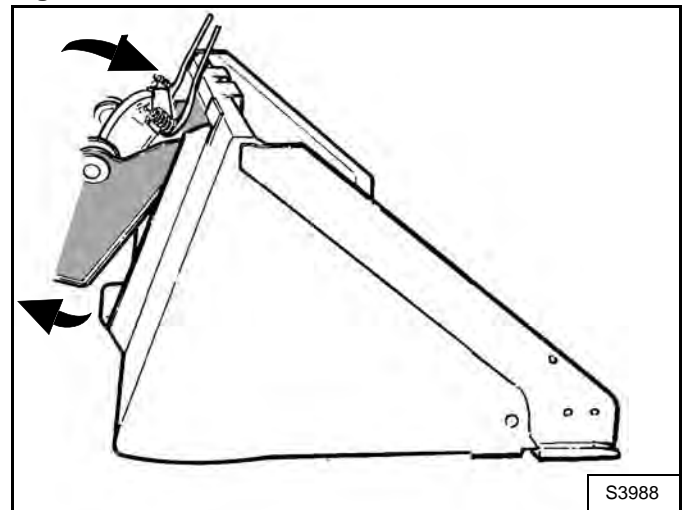

Tilt the Bob-Tach forward while backing the loader away from the bucket or attachment [Figure 70].

**NOTE:** In muddy conditions or to prevent the attachment from freezing to the ground, put the attachment on planks or blocks before removing it from the machine.

## OPERATING PROCEDURE

### Inspect The Work Area

Before beginning operation, inspect the work area for unsafe conditions.

Look for sharp drop-offs or rough terrain. Have underground utility lines (gas, electrical, water, sewer, irrigation, etc.) located and marked.

Remove objects or other construction material that could damage the loader or cause personal injury.

Always check ground conditions before starting your work:

- Inspect for signs of instability such as cracks or settlement.
- Be aware of weather conditions that can affect ground stability.
- Check for adequate traction if working on a slope.

### Basic Operating Instructions

Always warm the engine and hydrostatic system before operating the loader.

## IMPORTANT

**Machines warmed up with moderate engine speed and light load have longer life.**

I-2015-0284

Operate the loader with engine at full speed for maximum horsepower. Move the steering levers only a small amount to operate the loader slowly.

New operators must operate the loader in an open area without bystanders. Operate the controls until the loader can be handled at an efficient and safe rate for all conditions of the work area.

### *Operating Near An Edge Or Water*

Keep the loader as far back from the edge as possible and the loader wheels perpendicular to the edge so that if part of the edge collapses, the loader can be moved back.

Always move the loader back at any indication the edge may be unstable.



## WARNING

### **MACHINE TIPPING OR ROLLOVER CAN CAUSE SERIOUS INJURY OR DEATH**

- **Keep the lift arms as low as possible.**
- **Do not travel or turn with the lift arms up.**
- **Turn on level ground. Slow down when turning.**
- **Go up and down slopes, not across them.**
- **Keep the heavy end of the machine uphill.**
- **Do not overload the machine.**
- **Check for adequate traction.**

W-2018-1112

### Driving On Public Roads

When operating on a public road or highway, always follow local regulations. For example: Slow Moving Vehicle Sign or direction signals may be required.

## OPERATING PROCEDURE (CONT'D)

### Operating With A Full Bucket

Figure 71

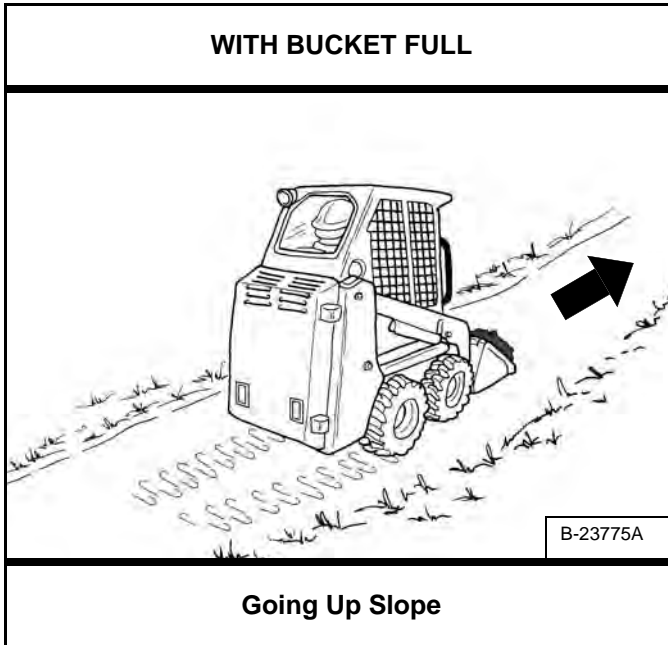

### Operating With An Empty Bucket

Figure 73

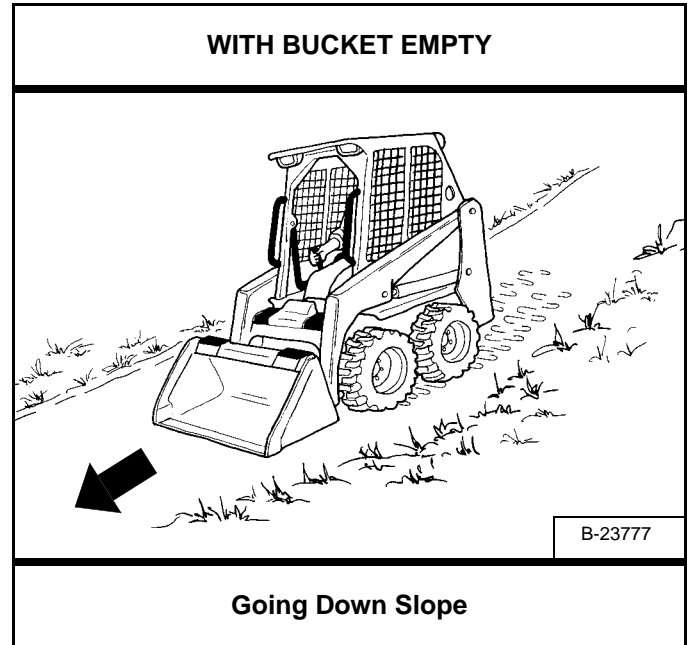

Figure 72

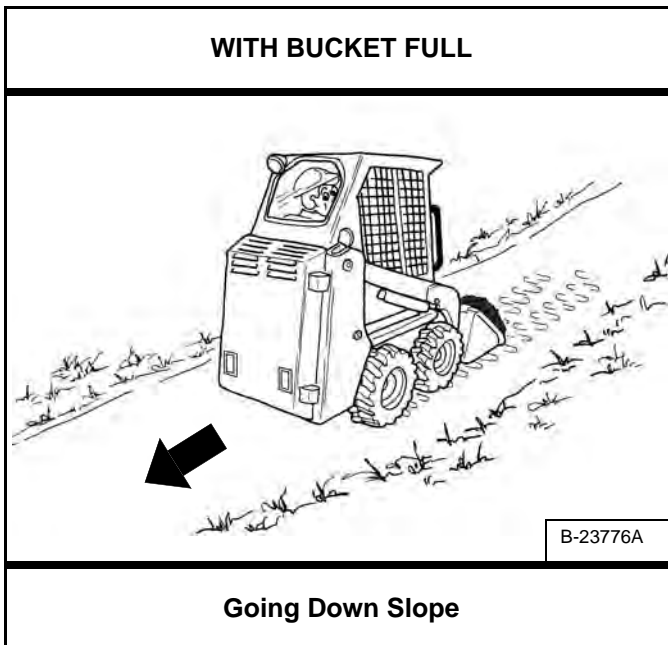
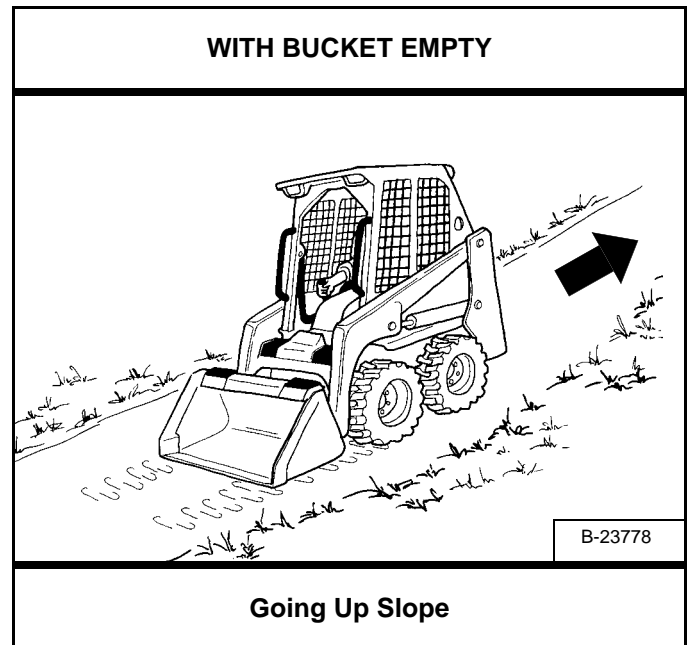

Figure 74



With a full bucket, go up or down the slope with the bucket (heavy end) toward the top of the slope [Figure 71] and [Figure 72].

With an empty bucket, go up or down the slope with the back of the loader (heavy end) toward the top of the slope [Figure 73] and [Figure 74].

Raise the bucket only high enough to avoid obstructions on rough ground.

## OPERATING PROCEDURE (CONT'D)

### Filling And Emptying The Bucket

#### Filling

Figure 75

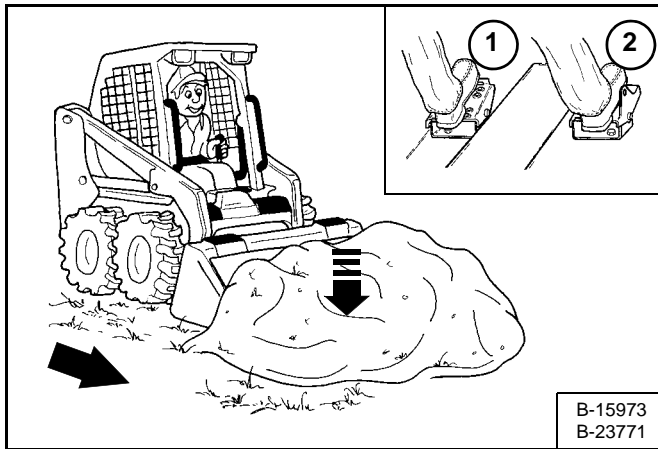
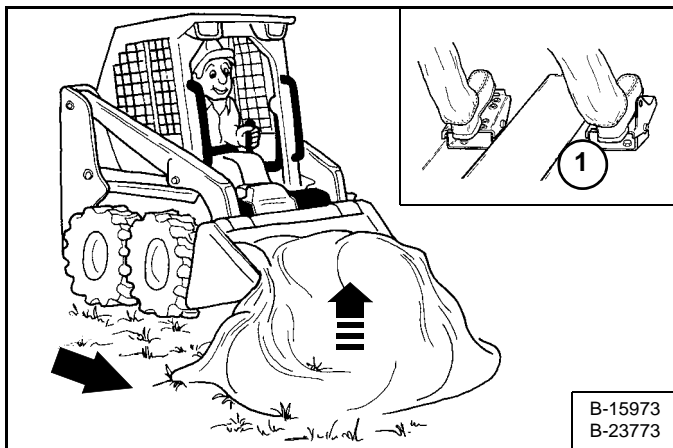

Figure 76



Lower the lift arms all the way by pushing the toe of the left pedal (Item 1) [Figure 75]. Tilt the bucket forward by pushing the toe of the right pedal (Item 2) [Figure 75] until the cutting edge of the bucket is on the ground.

Drive slowly forward into the material. Tilt the bucket backward all the way by pushing the heel of the right pedal (Item 1) [Figure 76] when the bucket is full.

Drive backward away from the material.

## WARNING

Load, unload and turn on flat level ground. Do not exceed Rated Operating Capacity (ROC) shown on sign (decal) in cab. Failure to obey warnings can cause the machine to tip or rollover and cause injury or death.

W-2056-1112

#### Emptying

Figure 77

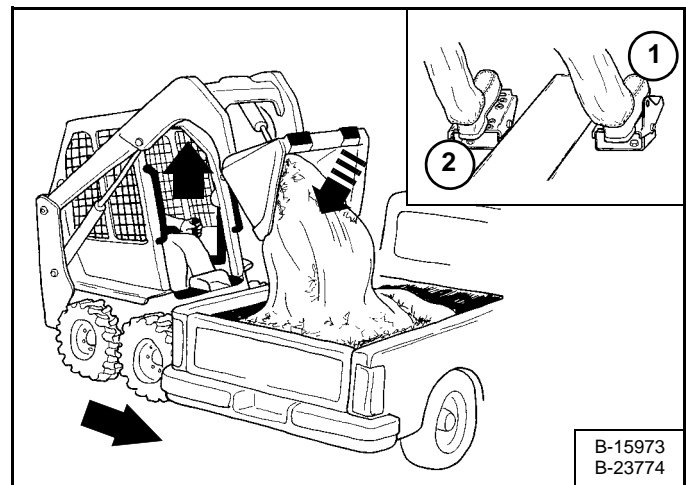

Keep the bucket low when moving to the area where you want to empty the bucket.

Level the bucket by pushing the toe of the right pedal (Item 1) while raising the lift arms to help prevent material from falling off the back of the bucket. Raise the lift arms by pushing the heel of the left pedal (Item 2) [Figure 77].

Drive forward slowly until the bucket is over the top of the truck box or bin [Figure 77].

Empty the bucket by pushing the toe of the right pedal (Item 1) [Figure 77]. If all the material is near the side of the truck or bin, use the bucket tilt to move it to the other side.

## WARNING

Never dump over an obstruction, such as a post, that can enter the operator cab. The machine could tip forward and cause injury or death.

W-2057-0694

## OPERATING PROCEDURE (CONT'D)

### Leveling The Ground Using Float

Figure 78

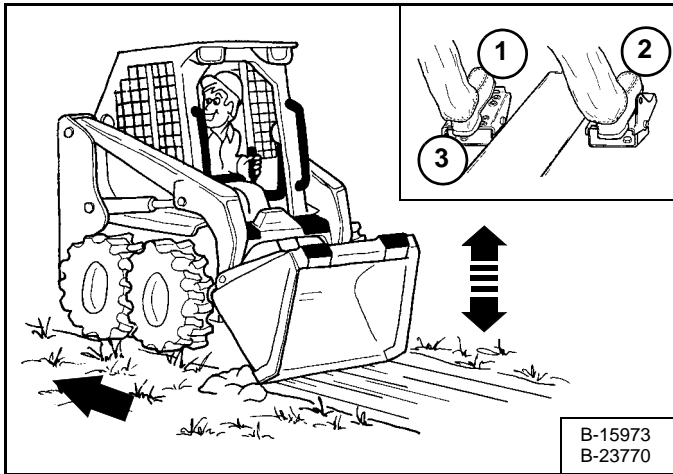

Put the lift arms in *float* position by pushing the toe of the left pedal (Item 1) [Figure 78] until it is locked in the forward position.

Tilt the bucket forward by pushing the toe of the right pedal (Item 2) [Figure 78] to change the position of the cutting edge of the bucket.

With the bucket tilted farther forward, there is more force on the cutting edge and more loose material can be moved.

Drive backward to level loose material [Figure 78].

Push the heel of the left pedal (Item 3) [Figure 78] to unlock the float position.

# IMPORTANT

Never drive forward when the hydraulic control for lift arms is in float position.

I-2005-1285

### Digging And Filling A Hole

#### Digging

Figure 79

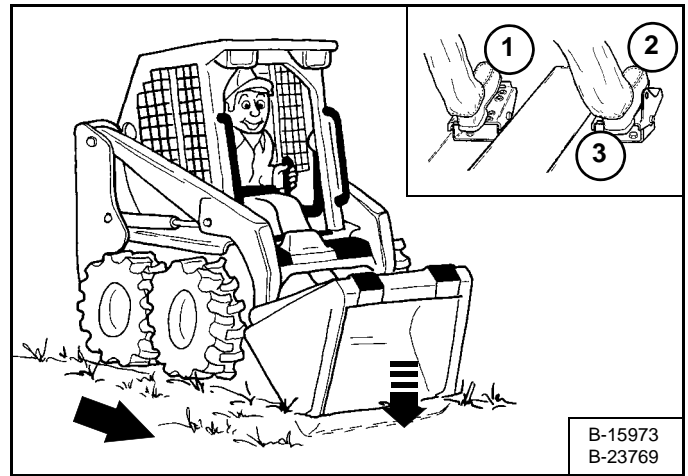

Lower the lift arms all the way by pushing the toe of the left pedal (Item 1) [Figure 79]. Put the cutting edge of the bucket on the ground by pushing the toe of the right pedal (Item 2) [Figure 79].

Drive forward slowly and continue to tilt the bucket down (Item 2) [Figure 79] until it enters the ground.

Raise the cutting edge a small amount by pushing the heel of the right pedal (Item 3) [Figure 79] to increase traction and keep an even digging depth. Continue to drive forward until the bucket is full. When the ground is hard, raise and lower the cutting edge of the bucket (Items 2 and 3) [Figure 79] while driving forward slowly.

Figure 80

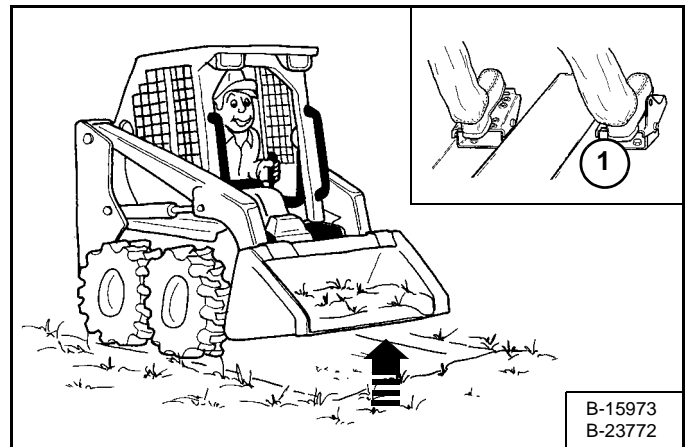

Tilt the bucket backward by pushing the heel of the right pedal (Item 1) [Figure 80] as far as it will go when the bucket is full.

## OPERATING PROCEDURE (CONT'D)

### Digging And Filling A Hole (Cont'd)

#### Filling

Figure 81

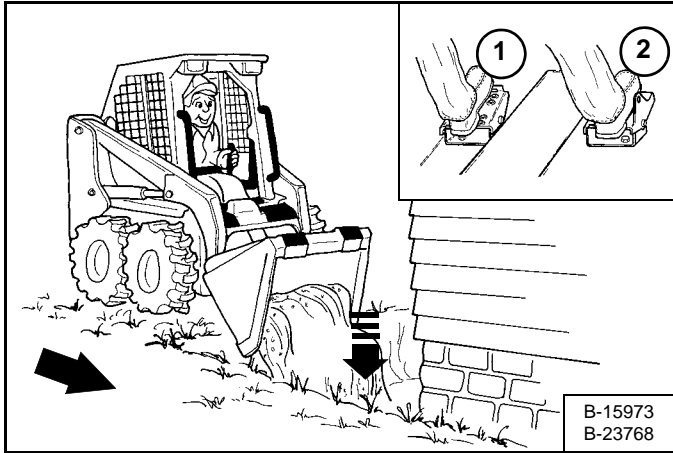

Lower the lift arms by pushing the toe of the left pedal (Item 1) **[Figure 81]**. Put the cutting edge of the bucket on the ground by pushing the toe of the right pedal (Item 2) **[Figure 81]**. Drive forward to the edge of the hole to push the material into the hole.

Tilt the bucket farther forward (Item 2) **[Figure 81]** as soon as it is past the edge of the hole.

If necessary, raise the lift arms to empty the bucket.

## TOWING THE LOADER

### Procedure

Because of the design of the loader, there is not a recommended towing procedure.

- The loader can be lifted onto a transport vehicle.
- The loader can be skidded a short distance to move for service (EXAMPLE: Move onto a transport vehicle.) without damage to the hydrostatic system. (The wheels will not turn.) There might be slight wear to the tires when the loader is skidded.

The towing chain (or cable) must be rated at 1.5 times the weight of the loader. (See Performance on Page 130.)



## LIFTING THE LOADER

### Single-Point Lift

# ! WARNING

#### AVOID INJURY OR DEATH

- Before lifting, check fasteners on single point lift and operator cab.
- Assemble front cab fasteners as shown in this manual.
- Never allow riders in the cab or bystanders within 5 m (15 ft) while lifting the machine.

W-2007-0910

The loader can be lifted with the Single-Point Lift which is available as a kit from your Bobcat Loader dealer.

The Single-Point Lift, supplied by Bobcat, is designed to lift and support the Bobcat Loader without affecting rollover and falling object protection features of the operator cab.

Figure 82

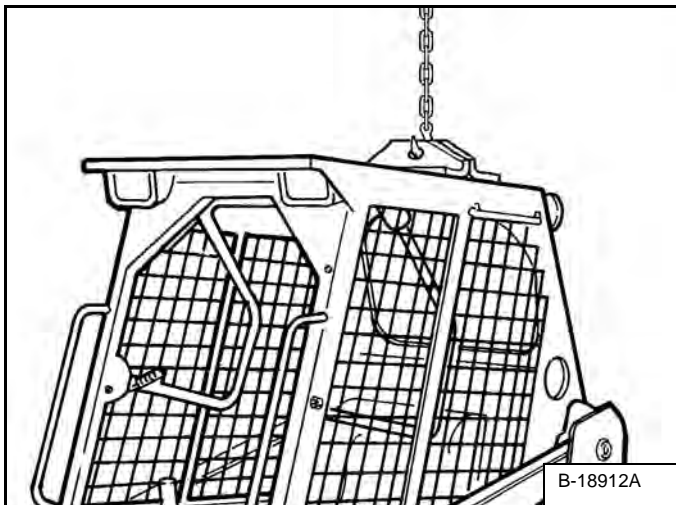

Attach lift to lift eye [Figure 82].

**NOTE:** Be sure the lifting equipment is of adequate size and capacity for the weight of the loader. (See Performance on Page 130.)

## TRANSPORTING THE LOADER ON A TRAILER

### Loading And Unloading

# ! WARNING

#### AVOID SERIOUS INJURY OR DEATH

Adequately designed ramps of sufficient strength are needed to support the weight of the machine when loading onto a transport vehicle. Wood ramps can break and cause personal injury.

W-2058-0807

Be sure the transport and towing vehicles are of adequate size and capacity for the weight of the loader. (See Performance on Page 130.)

Figure 83

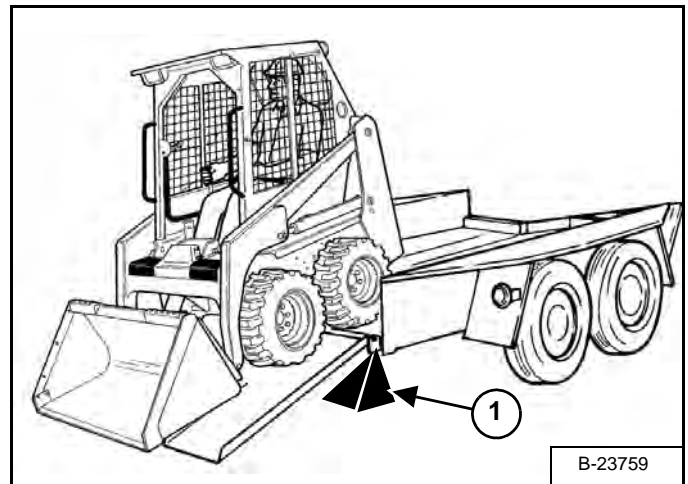

A loader with an empty bucket or no attachment must be loaded backward onto the transport vehicle [Figure 83].

The rear of the trailer must be blocked or supported (Item 1) [Figure 83] when loading or unloading the loader to prevent the front end of the trailer from raising up.

## TRANSPORTING THE LOADER ON A TRAILER (CONT'D)

### Fastening

Figure 84

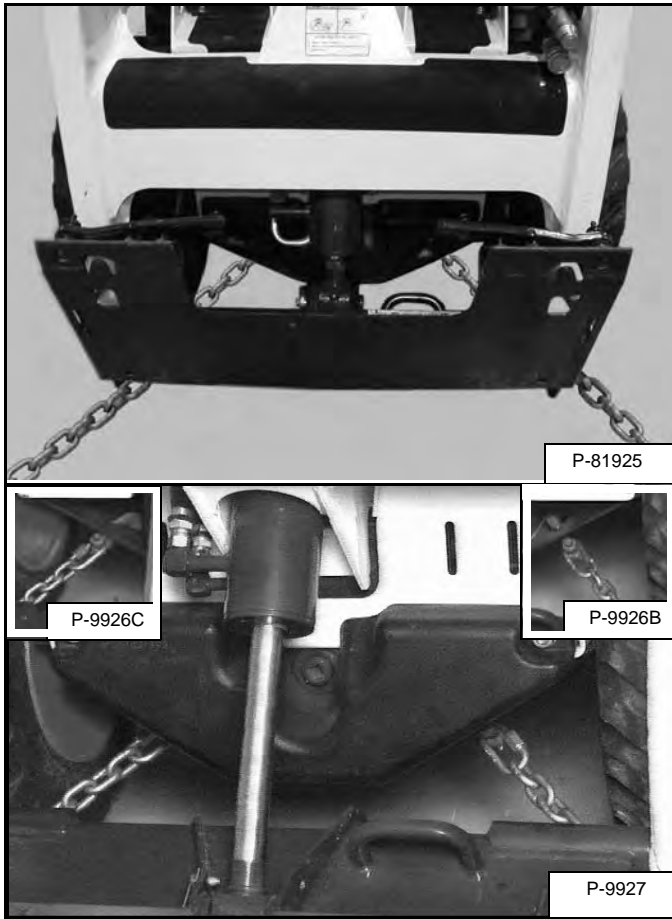

Use the following procedure to fasten the Bobcat Loader to the transport vehicle to prevent the loader from moving during sudden stops or when going up or down slopes [Figure 84].

- Lower the bucket or attachment to the floor.
- Stop the engine.
- Engage the parking brake.
- Install chains at the front tie down positions [Figure 84].
- Fasten each end of the chain to the transport vehicle.

Figure 85

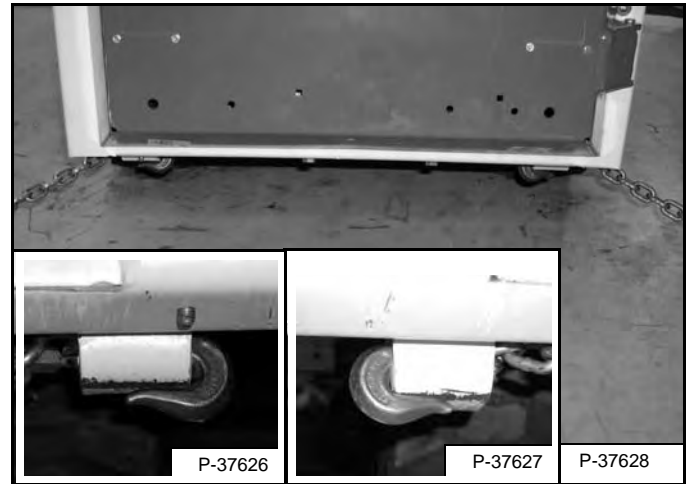

- Install chains at the rear tie down positions [Figure 85].
- Fasten each end of the chain to the transport vehicle.

## PREVENTIVE MAINTENANCE

MAINTENANCE SAFETY .....	69
SERVICE SCHEDULE .....	71
Chart .....	71
BOBCAT INTERLOCK CONTROL SYSTEM (BICS™) .....	72
Inspecting The BICS™ (Engine STOPPED - Key ON) .....	72
Inspecting The Seat Bar Sensor (Engine RUNNING) .....	72
Inspecting The Traction Lock (Engine RUNNING) .....	72
Inspecting The Lift Arm Bypass Control .....	72
Inspecting Deactivation Of The Auxiliary Hydraulics System .....	73
SEAT BAR RESTRAINT SYSTEM .....	74
Description .....	74
Inspecting .....	74
Maintaining .....	74
SEAT BELT .....	75
Inspection And Maintenance .....	75
LIFT ARM SUPPORT DEVICE .....	76
Installing .....	76
Removing .....	77
BACK-UP ALARM SYSTEM .....	78
Description .....	78
Inspecting .....	78
Adjusting Switch Position .....	79
OPERATOR CAB .....	80
Description .....	80
Raising .....	80
Lowering .....	81
REAR DOOR (TAILGATE) .....	83
Opening And Closing .....	83
AIR CLEANER SERVICE .....	84
Replacing Filter Elements .....	84
FUEL SYSTEM .....	85
Fuel Specifications .....	85
Biodiesel Blend Fuel .....	85
Filling The Fuel Tank .....	86
Fuel Filter .....	87
Removing Air From The Fuel System .....	87

ENGINE LUBRICATION SYSTEM .....	88
Checking And Adding Engine Oil .....	88
Engine Oil Chart .....	88
Removing And Replacing Oil And Filter .....	88
ENGINE COOLING SYSTEM .....	89
Cleaning .....	89
Checking Level .....	89
Removing And Replacing Coolant .....	90
ELECTRICAL SYSTEM .....	91
Description .....	91
Fuse And Relay Location / Identification .....	91
Battery Maintenance .....	92
Using A Booster Battery (Jump Starting) .....	92
Removing And Installing Battery .....	94
HYDRAULIC / HYDROSTATIC SYSTEM .....	95
Checking And Adding Fluid .....	95
Hydraulic / Hydrostatic Fluid Chart .....	95
Removing And Replacing Hydraulic Fluid .....	96
Removing And Replacing Hydraulic / Hydrostatic Filter .....	97
Breather Cap .....	97
SPARK ARRESTER MUFFLER .....	98
Cleaning Procedure .....	98
TIRE MAINTENANCE .....	99
Wheel Nuts .....	99
Rotating .....	99
Mounting .....	99
FINAL DRIVE TRANSMISSION (CHAINCASE) .....	100
Checking And Adding Oil .....	100
Removing And Replacing Oil .....	100
ALTERNATOR BELT .....	101
Belt Adjustment .....	101
Belt Replacement .....	101
DRIVE BELT .....	102
Belt Adjustment .....	102
Belt Replacement .....	102
LUBRICATING THE LOADER .....	103
Lubrication Locations .....	103
PIVOT PINS .....	105
Inspection And Maintenance .....	105

BOB-TACH .....	106
Inspection And Maintenance .....	106
LOADER STORAGE AND RETURN TO SERVICE .....	107
Storage .....	107
Return To Service .....	107



**Bobcat®**

# MAINTENANCE SAFETY



## WARNING

Instructions are necessary before operating or servicing machine. Read and understand the Operation & Maintenance Manual, Operator's Handbook and signs (decals) on machine. Follow warnings and instructions in the manuals when making repairs, adjustments or servicing. Check for correct function after adjustments, repairs or service. Untrained operators and failure to follow instructions can cause injury or death.

W-2003-0807



**Safety Alert Symbol:** This symbol with a warning statement, means: "Warning, be alert! Your safety is involved!" Carefully read the message that follows.

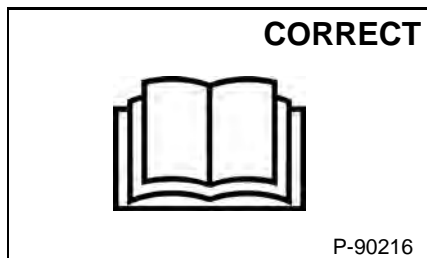

P-90216

⚠ Never service the Bobcat Skid-Steer Loader without instructions.

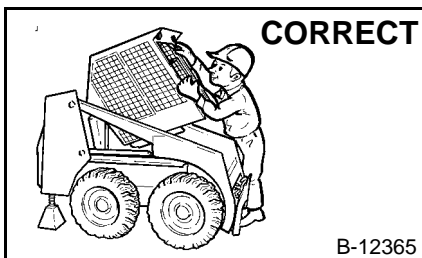

B-12365

⚠ Use the correct procedure to lift or lower operator cab.

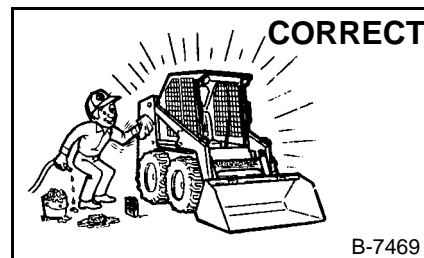

B-7469

⚠ Cleaning and maintenance are required daily.

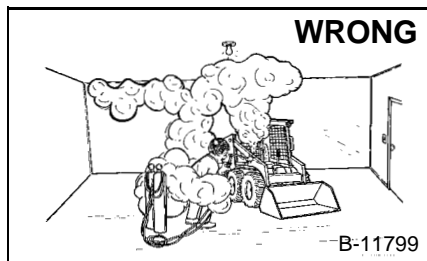

B-11799

- ⚠ Have good ventilation when welding or grinding painted parts.
- ⚠ Wear dust mask when grinding painted parts. Toxic dust and gas can be produced.
- ⚠ Avoid exhaust fume leaks which can kill without warning. Exhaust system must be tightly sealed.

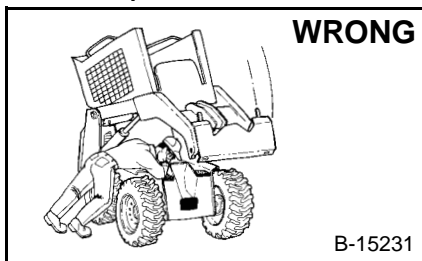

B-15231

⚠ Disconnecting or loosening any hydraulic tubeline, hose, fitting, component or a part failure can cause lift arms to drop. Do not go under lift arms when raised unless supported by an approved lift arm support device. Replace it if damaged.

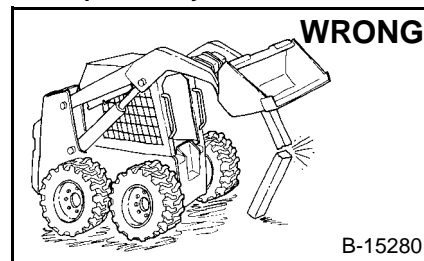

B-15280

- ⚠ Never work on loader with lift arms up unless lift arms are held by an approved lift arm support device. Replace if damaged.
- ⚠ Never modify equipment or add attachments not approved by Bobcat Company.

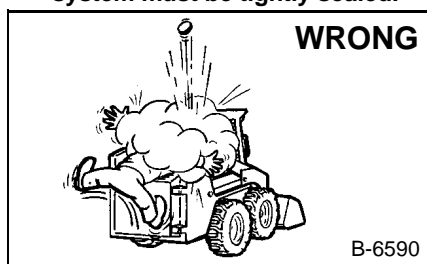

B-6590

- ⚠ Stop, cool and clean engine of flammable materials before checking fluids.
- ⚠ Never service or adjust loader with the engine running unless instructed to do so in the manual.
- ⚠ Avoid contact with leaking hydraulic fluid or diesel fuel under pressure. It can penetrate the skin or eyes.
- ⚠ Never fill fuel tank with engine running, while smoking or when near open flame.

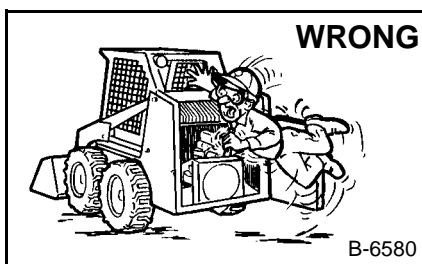

B-6580

- ⚠ Keep body, jewelry and clothing away from moving parts, electrical contact, hot parts and exhaust.
- ⚠ Wear eye protection to guard from battery acid, compressed springs, fluids under pressure and flying debris when engines are running or tools are used. Use eye protection approved for type of welding.
- ⚠ Keep rear door closed except for service. Close and latch door before operating the loader.



B-6589

- ⚠ Lead-acid batteries produce flammable and explosive gases.
- ⚠ Keep arcs, sparks, flames and lighted tobacco away from batteries.
- ⚠ Batteries contain acid which burns eyes or skin on contact. Wear protective clothing. If acid contacts body, flush well with water. For eye contact flush well and get immediate medical attention.

Maintenance procedures which are given in the Operation & Maintenance Manual can be performed by the owner/operator without any specific technical training. Maintenance procedures which are **not** in the Operation & Maintenance Manual must be performed **ONLY BY QUALIFIED BOBCAT SERVICE PERSONNEL**. Always use genuine Bobcat replacement parts. The Service Safety Training Course is available from your Bobcat dealer.

MSW01-0409



**Bobcat®**



## SERVICE SCHEDULE

### Chart

Maintenance work must be done at regular intervals. Failure to do so will result in excessive wear and early failures. The service schedule is a guide for correct maintenance of the Bobcat Loader.

 <b>WARNING</b>	<p>Instructions are necessary before operating or servicing machine. Read and understand the Operation &amp; Maintenance Manual, Operator's Handbook and signs (decals) on machine. Follow warnings and instructions in the manuals when making repairs, adjustments or servicing. Check for correct function after adjustments, repairs or service. Untrained operators and failure to follow instructions can cause injury or death.</p>	<b>W-2003-0807</b>
--	--	--------------------

SERVICE SCHEDULE		HOURS						
		8-10	50	100	150	250	500	1000
Engine Oil	Check the oil level and add as needed. Do not overfill.							
Engine Air Filter and Air System	Check condition indicator. Service only when required. Check for leaks and damaged components.							
Engine Cooling System	Clean debris from oil cooler, radiator and e. Check coolant level COLD and add premixed coolant as needed.							
Fuel Filter	Remove the trapped water.							
Lift Arms, Cylinders, Bob-Tach Pivot Pins and Wedges	Lubricate with multipurpose lithium based grease.							
Tires	Check for damaged tires and correct air pressure. Inflate to MAXIMUM pressure shown on sidewall of tire.							
Seat Bar, Control Interlocks, Seat Belt	Check the condition of seat belt. Check the seat bar and control interlocks for correct operation. Clean dirt and debris from moving parts.							
Front Horn / Back-up Alarm	Check for proper function.							
Bobcat Interlock Control Systems (BICS™)	Check for correct function. Lift and Tilt functions MUST NOT operate with seat bar raised. See details in this Manual.							
Safety Signs and Safety Treads	Check for damaged signs (decals) and safety treads. Replace any signs or safety treads that are damaged or worn.							
Operator Cab	Check the fastening bolts, washers and nuts. Check the condition of the cab.							
Indicators and Lights	Check for correct operation of all indicators and lights.							
Heater Filter (If Equipped)	Clean or replace filter as needed.							
Hydraulic Fluid, Hoses and Tubelines	Check fluid level and add as needed. Check for damage and leaks. Repair or replace as needed.							
Final Drive Trans. (Chaincase)	Check oil level and add oil as needed.							
Parking Brake, Foot Pedals and Steering Levers	Check for correct operation. Repair or adjust as needed.							
Wheel Nuts	Check for loose wheel nuts and tighten to correct torque. (See TIRE MAINTENANCE in this manual.)	☐						
Battery	Check cables, connections and electrolyte level. Add distilled water as needed.							
Spark Arrester Muffler	Empty Spark Chamber.							
Engine Oil and Filter	Replace oil and filter.		*					
Alternator Belt	Check tension and adjust as needed.							
Fuel Filter	Replace filter element.							
Steering Shaft	Grease fittings.							
Engine / Hydro. Drive Belt	Check for wear or damage. Adjust or replace as needed.		○					
Bobcat Interlock Control System (BICS™)	Check the function of the lift arm bypass control.							
Hydraulic Reservoir Breather Cap	Replace the reservoir breather cap.							
Hyd./Hydro. Filter	Replace the filter element.		●					
Final Drive Trans. (Chaincase)	Replace the fluid.							
Hydraulic Reservoir	Replace the fluid.							
Coolant	Replace the coolant							Every 2 years

- ☐ Check every 8 - 10 hours for the first 50 hours, then as scheduled.
- \* First oil and filter change must occur at 50 hours, then as scheduled.
- Inspect new belt after first 50 hours, then as scheduled.
- Replace the hydraulic / hydrostatic filter element after the first 50 hours; thereafter when the transmission warning light comes ON while operating or as scheduled.
- Or every 12 months.

## BOBCAT INTERLOCK CONTROL SYSTEM (BICS™)

Perform the procedures on flat level ground and make sure the area is clear of bystanders.

### Inspecting The BICS™ (Engine STOPPED - Key ON)

Figure 86

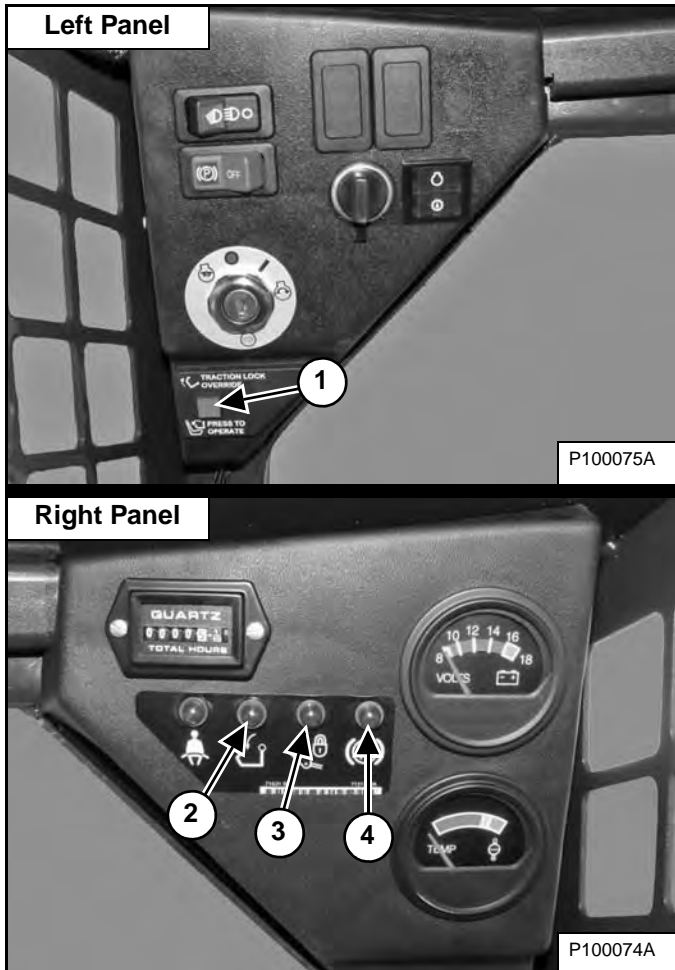

1. Sit in the operator's seat, fasten the seat belt, turn the key ON (Keyless Start Panel - enter the password / user code on the keypad), lower the seat bar and disengage the parking brake. Press the PRESS TO OPERATE LOADER button (Item 1). The three BICS™ lights (Items 2, 3 and 4) on the right instrument panel must be OFF (SEAT BAR, LIFT & TILT VALVE, and PARKING BRAKE) [Figure 86].
2. Raise the seat bar fully. The three BICS™ lights (Items 2, 3 and 4) [Figure 86] on the right instrument panel must be ON (SEAT BAR, LIFT & TILT VALVE, and PARKING BRAKE).

**NOTE:** Record what lights are blinking (if any) and the number of light flashes.

### Inspecting The Seat Bar Sensor (Engine RUNNING)

3. Fasten the seat belt, lower the seat bar and make sure the parking brake is engaged.
4. Start the engine and operate at low idle. Press the PRESS TO OPERATE LOADER button. While raising the lift arms, raise the seat bar fully. The lift arms must stop. Repeat using the tilt function.

### Inspecting The Traction Lock (Engine RUNNING)

5. Fasten seat belt, lower the seat bar, disengage the parking brake and press the PRESS TO OPERATE LOADER button. Raise the seat bar fully and move the steering levers slowly forward and backward. The traction drive system will be locked.
6. Fasten seat belt, lower the seat bar and press the PRESS TO OPERATE LOADER button. Engage the parking brake and move the steering levers slowly forward and backward. The traction drive system will be locked.

**NOTE:** The PARKING BRAKE light on the left instrument panel will remain ON until the engine is started, the PRESS TO OPERATE LOADER button is pressed and the parking brake is disengaged.

### Inspecting The Lift Arm Bypass Control

7. Raise the lift arms 2 m (6 ft) off the ground. Stop the engine. Turn the lift arm bypass control knob clockwise 1/4 turn. Pull out and hold the knob until the lift arms slowly lower.

**! WARNING**

#### AVOID INJURY OR DEATH

The Bobcat Interlock Control System (BICS™) must deactivate the lift, tilt, traction drive and front auxiliary hydraulic functions. If it does not, contact your dealer for service. DO NOT modify the system.

W-2689-0813

## BOBCAT INTERLOCK CONTROL SYSTEM (BICS™) (CONT'D)

### Inspecting Deactivation Of The Auxiliary Hydraulics System

Perform the procedures on flat level ground and make sure the area is clear of bystanders.

#### Engine Starting

**Figure 87**

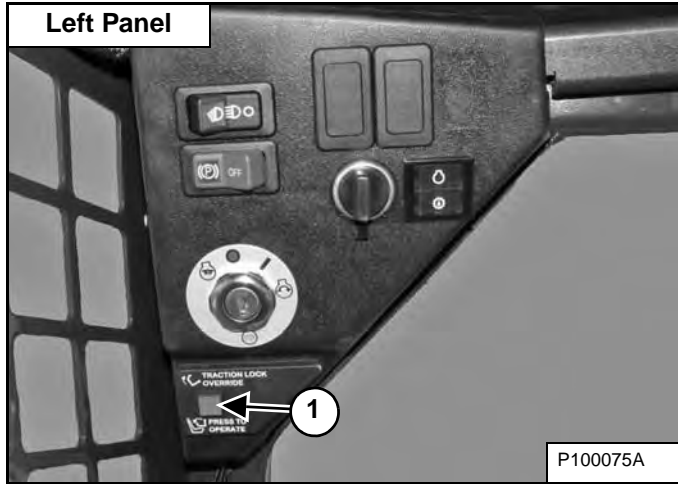

8. Install an attachment with hydraulic connections. (See Installing And Removing The Attachment on Page 55.) Perform the pre-starting procedure. (See PRE-STARTING PROCEDURE on Page 45.) Fasten the seat belt, lower the seat bar and make sure the parking brake is engaged. Start the engine. Move the Auxiliary Hydraulic Control Lever to the left or the right. (See Front Auxiliary Hydraulics Operation on Page 40.). There will not be hydraulic oil flow to the attachment.

Press the PRESS TO OPERATE LOADER button (Item 1) **[Figure 87]** and then engage the auxiliary hydraulics. The auxiliary hydraulic oil will flow to the attachment.

#### Engine Running

9. Install an attachment with hydraulic connections. (See Installing And Removing The Attachment on Page 55.) Perform the pre-starting procedure. (See PRE-STARTING PROCEDURE on Page 45.) Fasten the seat belt, lower the seat bar and make sure the parking brake is engaged. Start the engine. Press the PRESS TO OPERATE LOADER button (Item 1) **[Figure 87]**. Move the Auxiliary Hydraulic Control Lever to the left or the right. The auxiliary hydraulic oil will flow to the attachment. (See Front Auxiliary Hydraulics Operation on Page 40.) Raise the seat bar. The auxiliary hydraulic oil flow to the attachment will STOP.

**! WARNING**

#### AVOID INJURY OR DEATH

**The Bobcat Interlock Control System (BICS™) must deactivate the lift, tilt, traction drive and front auxiliary hydraulic functions. If it does not, contact your dealer for service. DO NOT modify the system.**

W-2689-0813

## SEAT BAR RESTRAINT SYSTEM

### Description

The seat bar restraint system has a pivoting seat bar with armrests.

The operator controls the use of the seat bar. The seat bar in the down position helps to keep the operator in the seat.

The foot pedals have mechanical interlocks for the lift and tilt functions. The mechanical interlocks require the operator to lower the seat bar in order to operate the foot pedal controls.

When the seat bar is down, the PRESS TO OPERATE LOADER button is activated and the engine is running, the lift, tilt and traction drive functions can be operated.

When the seat bar is up, the lift and tilt control pedals are locked when returned to the NEUTRAL position.

### Inspecting

Sit in the seat and fasten the seat belt. Engage the parking brake. Pull the seat bar all the way down. Start the engine. Press the PRESS TO OPERATE LOADER button.

Operate the hydraulic controls to check that both the lift and tilt functions operate correctly. Raise the lift arms until the attachment is about 600 mm (2 ft) off the ground.

Raise the seat bar. Move the hydraulic controls. Pedals must be firmly locked in the NEUTRAL position. There must be no motion of the lift arms or tilt (attachment) when the controls are moved.

Lower the seat bar, press the PRESS TO OPERATE LOADER button, lower the lift arms. Operate the lift control. While the lift arms are going up, raise the seat bar. The lift arms must stop.

Lower the seat bar, press the PRESS TO OPERATE LOADER button, lower the lift arms and put the attachment flat on the ground. Stop the engine. Raise the seat bar. Operate the foot pedals to be sure they are firmly locked in the NEUTRAL position.

## WARNING

**The seat bar system must deactivate the lift and tilt control functions when the seat bar is up. See your Bobcat dealer for service if hydraulic controls do not deactivate.**

W-2465-0111

### Maintaining

See the service schedule for correct service interval. (See SERVICE SCHEDULE on Page 71.)

Figure 88

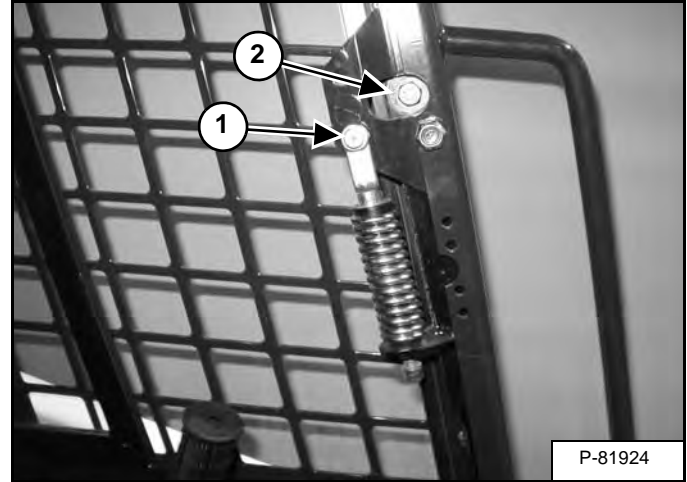
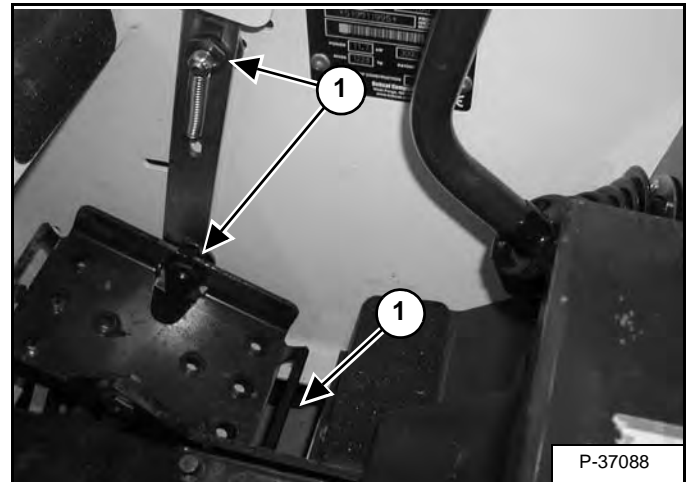

Figure 89



Use compressed air to clean any debris or dirt from the pivot parts (Item 1) [Figure 88] and [Figure 89]. Do not lubricate. Inspect all mounting hardware. The correct bolt torque is 34 - 38 N•m (25 - 28 ft-lb) for the seat bar pivot (Item 2) [Figure 88].

If the seat bar system does not function correctly, check for free movement of each linkage part. Check for excessive wear. Adjust pedal control linkage. Replace parts that are worn or damaged. Use only genuine Bobcat replacement parts.

## SEAT BELT

### Inspection And Maintenance

# WARNING

Failure to properly inspect and maintain the seat belt can cause lack of operator restraint resulting in serious injury or death.

W-2466-0703

Check the seat belt daily for correct function.

Inspect the seat belt system thoroughly yearly or more often if the machine is exposed to severe environmental conditions or applications.

The seat belt system should be repaired or replaced if it shows cuts, fraying, extreme or unusual wear, significant discolorations due to ultraviolet (UV) rays from the sun, dusty/dirty conditions, abrasion to the seat belt webbing, or damage to the buckle, latch plate, retractor (if equipped), or hardware.

The items below are referenced in **[Figure 90]**.

1. Check the seat belt webbing. If the system is equipped with a retractor, pull the webbing completely out and inspect the full length of the webbing. Look for cuts, wear, fraying, dirt and stiffness.
2. Check the buckle and latch for proper function. Make sure latch plate is not excessively worn, deformed or buckle is not damaged.
3. Check the retractor web storage device (if equipped) by extending the seat belt webbing to determine if it extends and retracts the webbing correctly.
4. Check webbing in areas exposed to ultraviolet (UV) rays from the sun or extreme dust or dirt. If the original color of the webbing in these areas is extremely faded and / or the webbing is packed with dirt, the webbing strength may have weakened.

See your Bobcat dealer for approved seat belt system replacement parts for your machine.

Figure 90

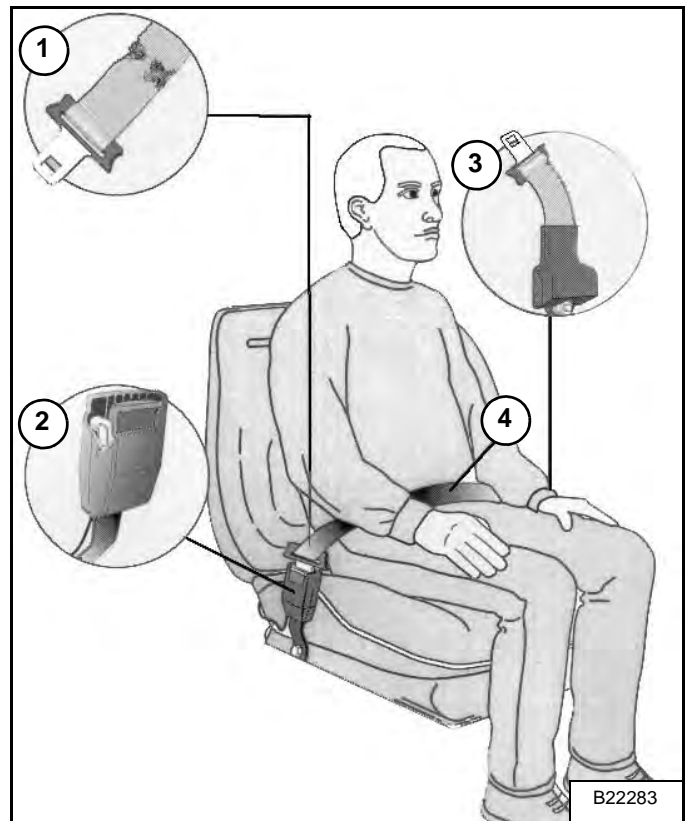

## LIFT ARM SUPPORT DEVICE

### Installing

Maintenance and service work can be done with the lift arms lowered. If the lift arms are raised, use the following procedures to engage and disengage an approved lift arm support device.

## ! WARNING

Never work on a machine with the lift arms up unless the lift arms are secured by an approved lift arm support device. Failure to use an approved lift arm support device can allow the lift arms or attachment to fall and cause injury or death.

Service lift arm support device if damaged or if parts are missing. Using a damaged lift arm support or with missing parts can cause lift arms to drop causing injury or death.

W-2572-0407

## ! DANGER

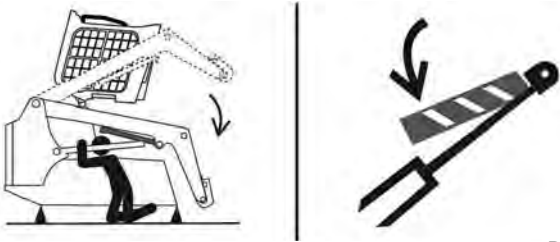

P-90328

### AVOID DEATH

- Disconnecting or loosening any hydraulic tubeline, hose, fitting, component or a part failure can cause lift arms to drop.
- Keep out of this area when lift arms are raised unless supported by an approved lift arm support. Replace if damaged.

D-1009-0409

Remove the attachment from the loader. (See Installing And Removing The Attachment on Page 55.)

## ! WARNING

Before the cab or the lift arms are raised for service, jackstands must be put under the rear corners of the frame. Failure to use jackstands can allow the machine to tip backward causing injury or death.

W-2014-0895

Figure 91

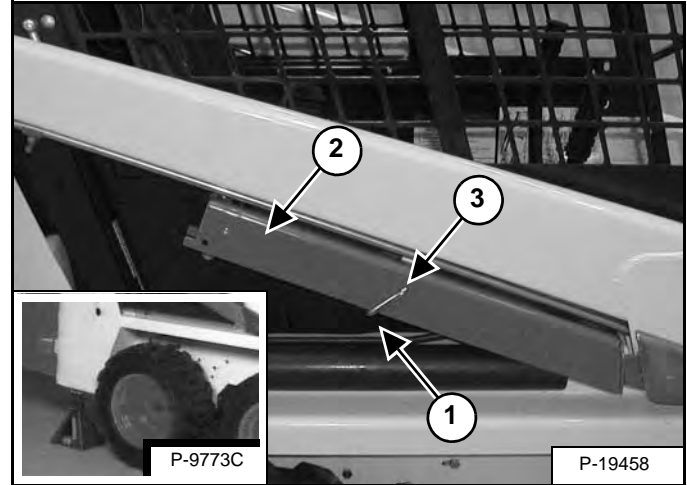

Put jackstands under the rear corners of the loader frame (Inset) [Figure 91].

Disconnect the spring (Item 1) from the lift arm support device retaining pin, Support the lift arm support device (Item 2) with your hand and remove the retaining pin (Item 3) [Figure 91].

Figure 92

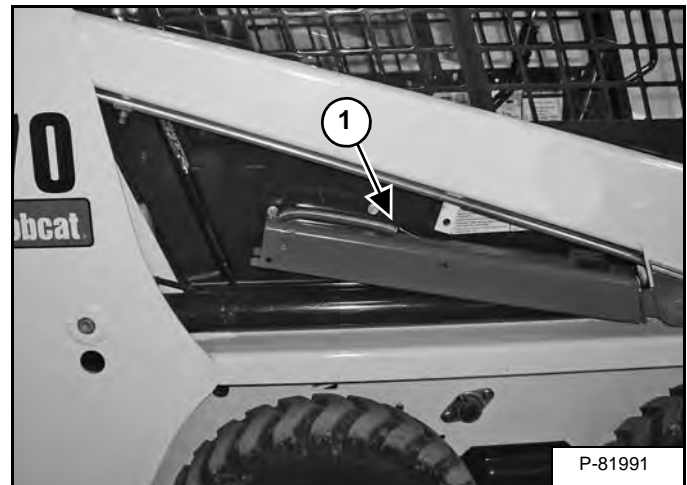

Lower the lift arm support device to the top of the lift cylinder. Hook the free end of the spring (Item 1) [Figure 92] to the lift arms support device so there will be no interference with the support device engagement.

## LIFT ARM SUPPORT DEVICE (CONT'D)

### Installing (Cont'd)

With the operator in the seat, seat belt fastened and seat bar lowered, start the engine, press the PRESS TO OPERATE LOADER button.

**Figure 93**

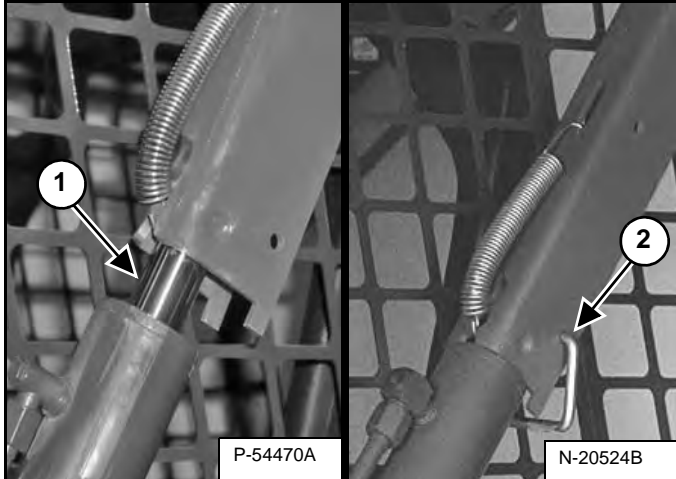

Raise the lift arms until the lift arm support device drops onto the lift cylinder rod (Item 1) **[Figure 93]**.

Lower the lift arms slowly until the support device is held between the lift arm and the lift cylinder.

Stop the engine. Raise the seat bar and move both pedals until both pedals lock.

Install pin (Item 2) **[Figure 93]** into the rear of the lift arm support device below the cylinder rod.

### Removing

**Figure 94**

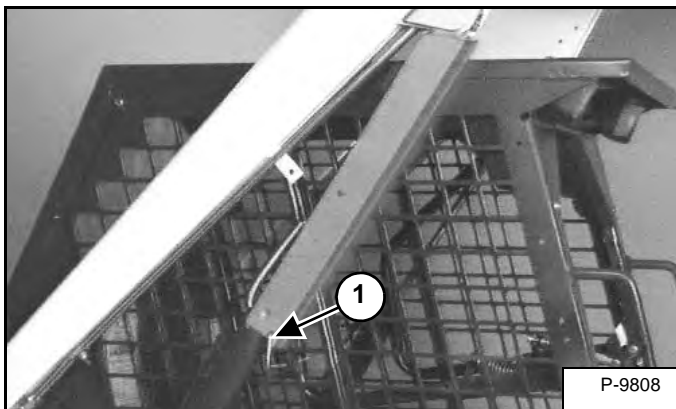

Remove the retaining pin (Item 1) **[Figure 94]** from the lift arm support device.

**Figure 95**

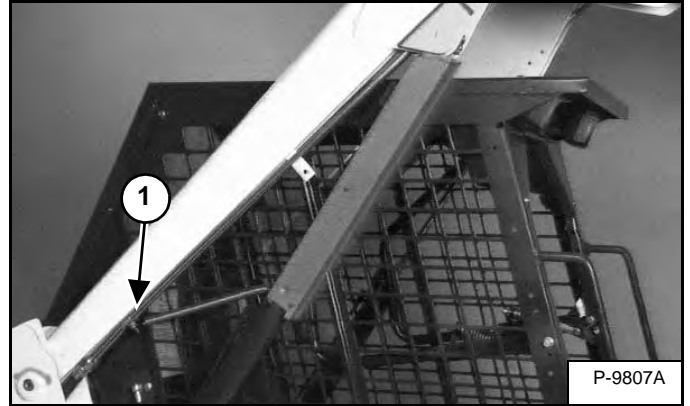

Connect the spring from the lift arm support device to the tubeline bracket (Item 1) **[Figure 95]** on the lift arms.

With the operator in the seat, seat belt fastened and seat bar lowered, start the engine, press the PRESS TO OPERATE LOADER button.

Raise the lift arms a small amount. The spring will lift the support device off the lift cylinder rod.

Lower the lift arms and stop the engine.

Raise the seat bar, disconnect the seat belt and move the pedals until both pedals lock.

Disconnect the spring from the bracket.

**Figure 96**

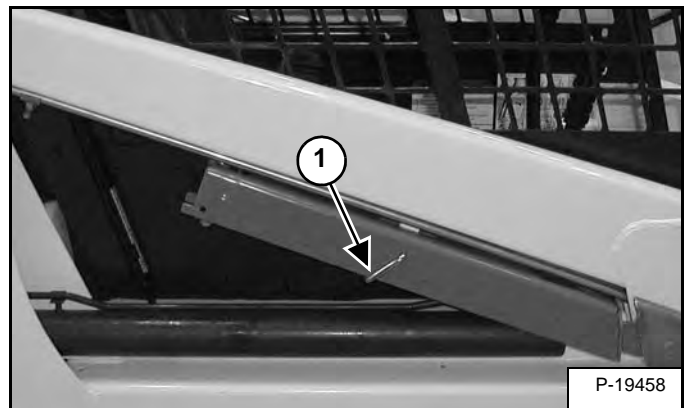

Raise the support device into storage position and insert the pin through the lift arm support device and bracket (Item 1) **[Figure 96]**.

Connect the spring to the pin **[Figure 96]**

Remove the jackstands.

## BACK-UP ALARM SYSTEM

### Description

The back-up alarm will sound when the operator moves both steering levers into the reverse position. Slight movement of the steering levers into the reverse position is required with hydrostatic transmissions, before the back-up alarm will sound.

### Inspecting

**Figure 97**



Inspect for damaged or missing back-up alarm decal (Item 1) [Figure 97]. Replace if required.

Sit in the seat and fasten the seat belt. Engage the parking brake. Pull the seat bar all the way down. Start the engine. Press the PRESS TO OPERATE LOADER button. Disengage the parking brake.

Move both steering levers into the reverse position. The back-up alarm must sound when all wheels are moving in reverse.

The back-up alarm is located on the inside of the rear door.

**Figure 98**

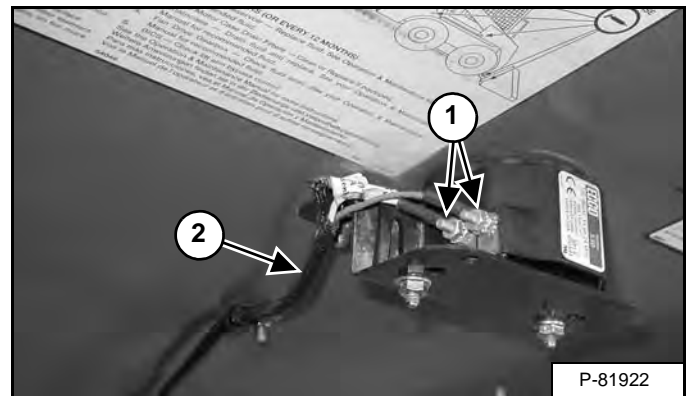

Inspect the back-up alarm electrical connections (Item 1) [Figure 98], wire harness (Item 2) [Figure 98] and back-up alarm switches (Item 1) [Figure 99] or [Figure 100] for tightness and damage. Repair or replace any damaged components.

If the back-up alarm switches require adjustment, (See Adjusting Switch Position on Page 79.)



## BACK-UP ALARM SYSTEM (CONT'D)

### Adjusting Switch Position

Stop the engine and exit the loader. (See STOPPING THE ENGINE AND LEAVING THE LOADER on Page 53.)

Raise the operator cab. (See OPERATOR CAB on Page 80.)

#### Earlier Models

Place the steering levers in the neutral position.

**Figure 99**

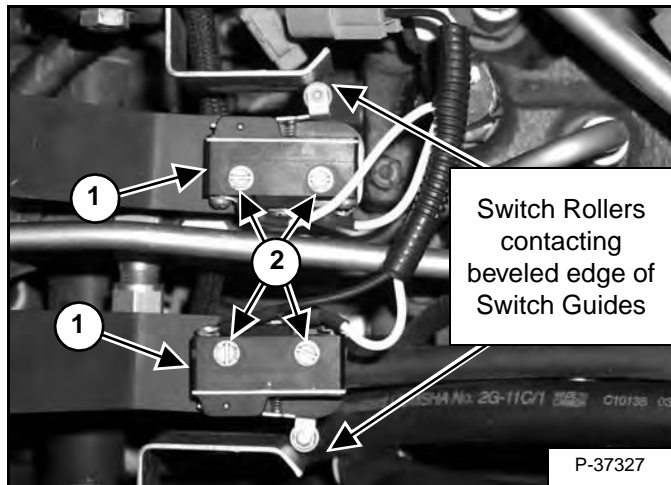

Loosen the screws (Item 2) securing the back-up alarm switches (Item 1) **[Figure 99]**.

Position the back-up alarm switch rollers so that they just make contact with the beveled edge of the switch guides without compressing the switch springs. Torque the screws (Item 2) **[Figure 99]** securing the switches to the bracket to 1,6 - 2,1 N•m (14 - 19 in-lb).

#### Later Models

**Figure 100**

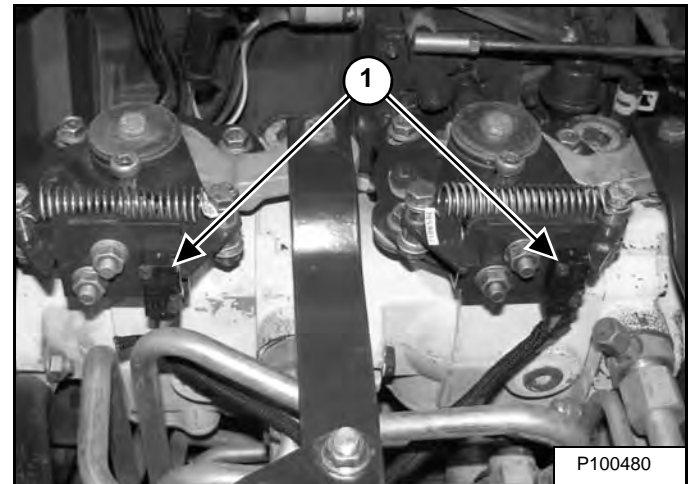

The back-up alarm switches (Item 1) **[Figure 100]** are located on the hydrostatic pump controls.

**NOTE:** The back-up alarm switches on later model loaders do not require adjustment. See your Bobcat dealer for service if your back-up alarm does not sound.

#### All Models

Lower the operator cab. (See Lowering on Page 81.)

Inspect back-up alarm system for proper function. (See Inspecting on Page 78.)

## OPERATOR CAB

### Description

The Bobcat Loader has an operator cab (ROPS and FOPS) as standard equipment to protect the operator from rollover and falling objects. The seat belt must be worn for rollover protection.

Check the cab, mounting, and hardware for damage. Never modify the cab. Replace the cab and hardware if damaged. See your Bobcat dealer for parts.

ROPS - Roll-Over Protective Structure per ISO 3471 and FOPS - Falling-Object Protective Structure per ISO 3449, Level I.

*Level I* - Protection from falling bricks, small concrete blocks, and hand tools encountered in operations such as highway maintenance, landscaping, and other construction sites.

## WARNING

Never modify operator cab by welding, grinding, drilling holes or adding attachments unless instructed to do so by Bobcat Company. Changes to the cab can cause loss of operator protection from rollover and falling objects, and result in injury or death.

W-2069-0200

## DANGER

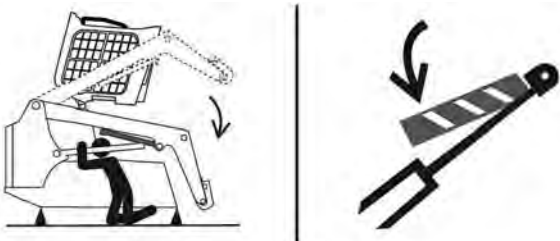

P-90328

### AVOID DEATH

- Disconnecting or loosening any hydraulic tubeline, hose, fitting, component or a part failure can cause lift arms to drop.
- Keep out of this area when lift arms are raised unless supported by an approved lift arm support. Replace if damaged.

D-1009-0409

### Raising

Always stop the engine before raising or lowering the cab.

Stop the loader on a level surface and lower the lift arms. If the lift arms must be up while raising the operator cab, install the lift arm support device. (See LIFT ARM SUPPORT DEVICE on Page 76.)

## WARNING

Before the cab or the lift arms are raised for service, jackstands must be put under the rear corners of the frame. Failure to use jackstands can allow the machine to tip backward causing injury or death.

W-2014-0895

## OPERATOR CAB (CONT'D)

### Raising (Cont'd)

Figure 101

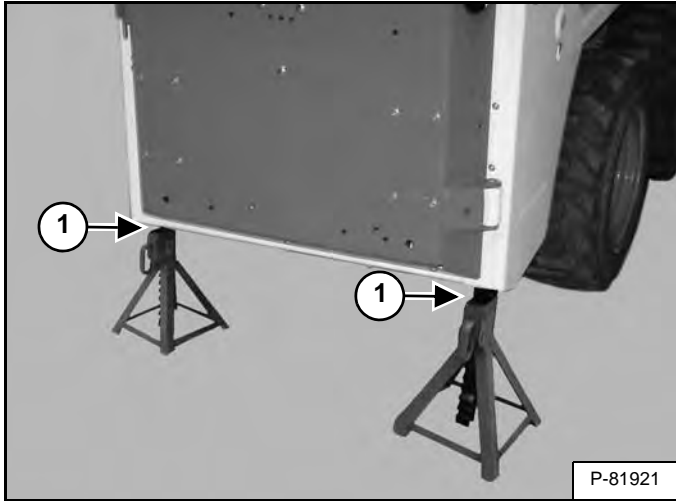

Install jackstands (Item 1) [Figure 101] under the rear corners of the loader frame.

Figure 102

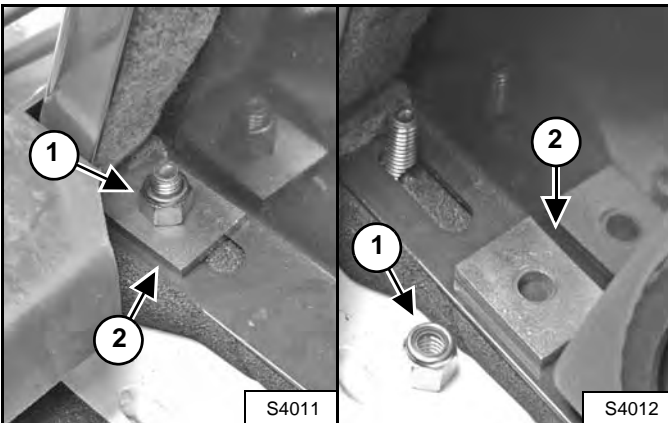

Remove the nut and plate (Items 1 and 2) [Figure 102] on the inside front corner of the cab (both sides).

Figure 103



Lift on the grab handle and bottom of the operator cab slowly until the cab is all the way up and the latching mechanism engages [Figure 103].

### Lowering



#### AVOID INJURY OR DEATH

The cab must be held to prevent falling while hand is in access hole.

W-2205-1207

Always stop the engine before raising or lowering the cab.

Figure 104

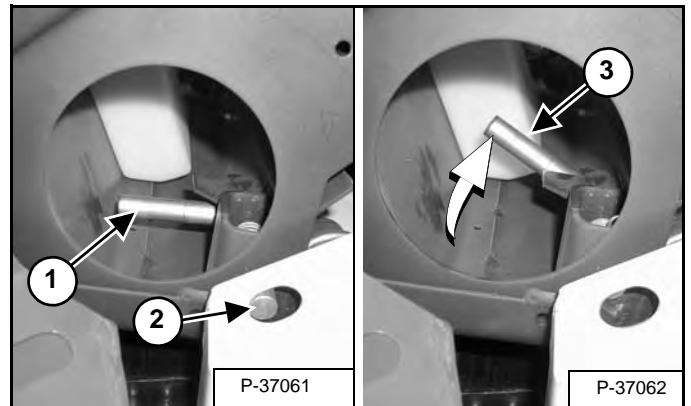

Hold the operator cab. Release the locking mechanism by pushing the lever (Item 1) in from the locked position (Item 2) and turning the lever until it stays in the unlocked position (Item 3) [Figure 104].

## OPERATOR CAB (CONT'D)

### Lowering (Cont'd)

REMOVE YOUR HAND FROM THE HOLE BEFORE LOWERING THE OPERATOR CAB.

Stand on the ground and pull the cab down. Avoid slippery surfaces. Use both hands to lower the cab all the way down.

**NOTE:** The weight of the cab increases when equipped with options and accessories such as cab door, heater, etc. In these cases, the cab may need to be raised slightly from the latch to be able to release the latch.

**NOTE:** Always use the grab handles (once you can reach them) to lower the cab.

Figure 105

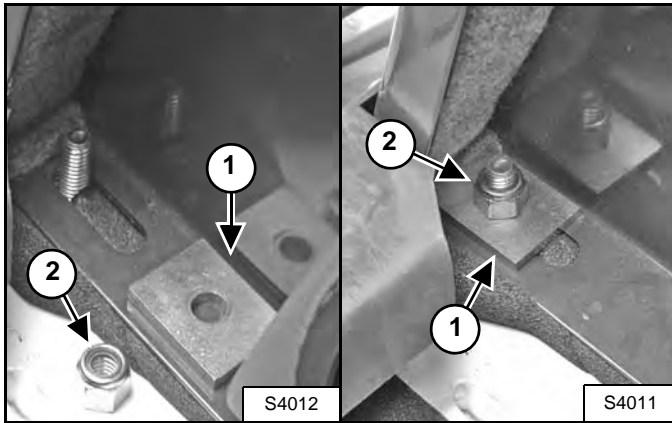

Install the plates and nuts (Items 1 and 2) [Figure 105] (both sides).

Tighten the nuts to 54 - 61 N•m (40 - 45 ft-lb) torque.

#### ***If Equipped With A Heater, Do The Following:***

##### *Earlier Model Heater*

**NOTE:** The heater hose connectors will disconnect when the cab is raised. The heater hose connectors must be reconnected for the heater to work after the cab is lowered and secured.

Move the seat as far forward as needed to access the heater hose connectors that are located at the rear of the cab.

Figure 106

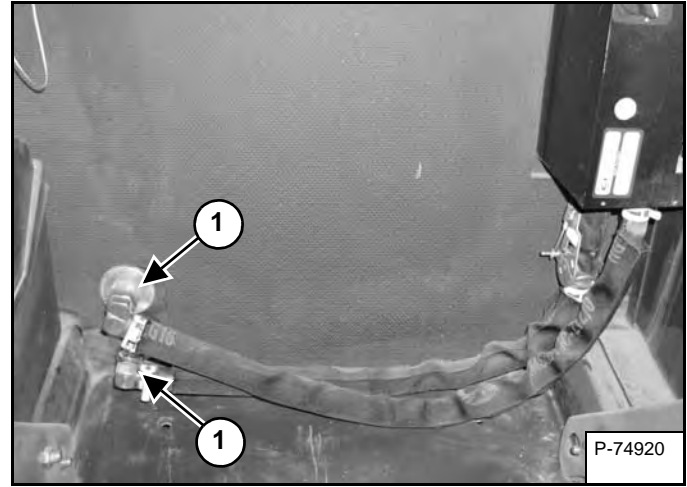

From behind the operator's seat, push the two heater quick connectors (Item 1) [Figure 106] into the heater couplers.

##### *Later Model Heater*

The heater hoses are routed through the rear wall of the cab behind the heater and will remain connected while raising and lowering the cab.

## REAR DOOR (TAILGATE)

### Opening And Closing

# WARNING

## AVOID INJURY OR DEATH

Never service or adjust the machine when the engine is running unless instructed to do so in the manual.

W-2012-0497

Figure 107

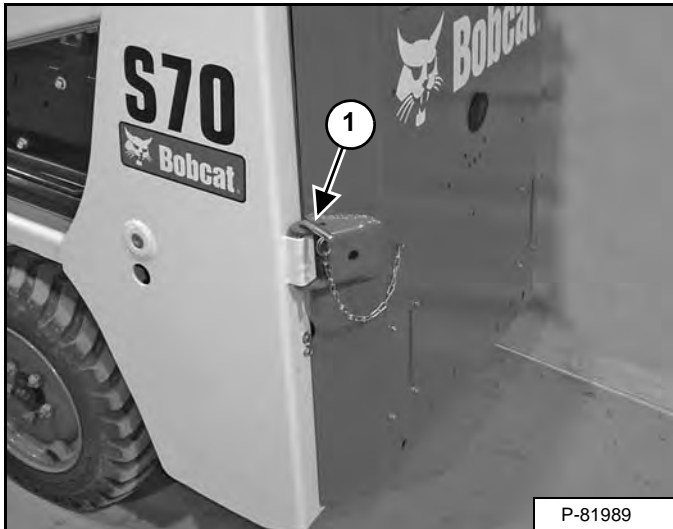

Remove the latch pin (Item 1) [Figure 107] and pull the rear door open.

Open the rear door for engine service.

# WARNING

Keep the rear door closed when operating the machine. Failure to do so could seriously injure a bystander.

W-2020-1285

Close the rear door before operating the loader.

## AIR CLEANER SERVICE

### Replacing Filter Elements

Figure 108

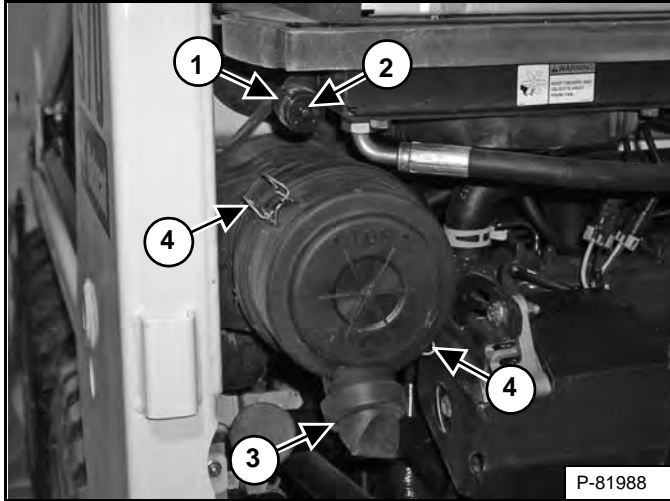

Replace the large (outer) filter element only when the red ring shows in the window of the condition indicator (Item 1) [Figure 108].

**NOTE:** Before replacing the filter element, push the button on the condition indicator (Item 2) [Figure 108]. Start the engine. If the red ring does not show, do not replace the filter element.

#### Outer Filter

Open the evacuator valve (Item 3) [Figure 108] to get rid of large particles of dust and dirt.

Remove the dust cover by lifting the latches (Item 4) [Figure 108].

Figure 109

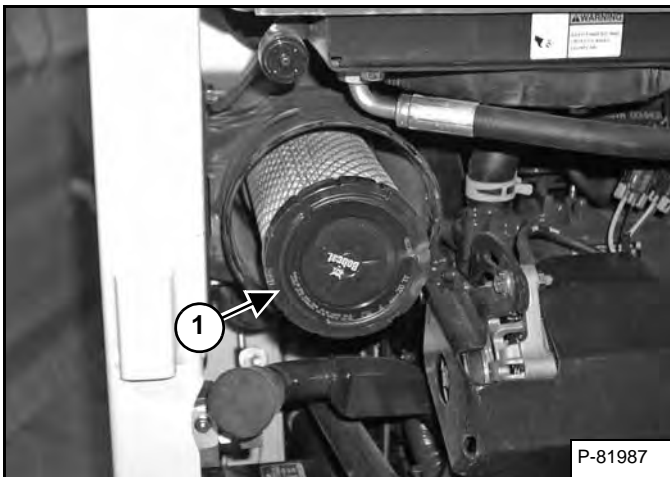

Pull the element straight out (Item 1) [Figure 109].

Install a new outer element.

Install the dust cover [Figure 108].

Check the air intake hose and the air cleaner housing for damage. Make sure all connections are tight.

#### Inner Filter

Replace the inner filter every third time the outer filter is replaced or when the red ring still shows in the indicator window after the outer filter has been replaced.

Figure 110

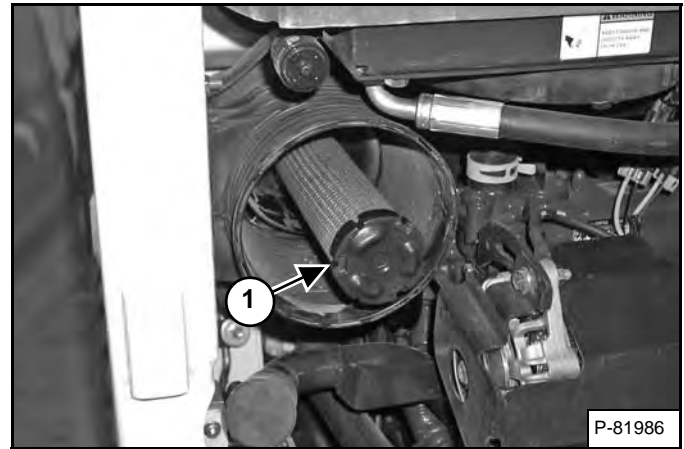

Remove the inner filter (Item 1) [Figure 110].

**NOTE:** Make sure all sealing surfaces are free of dirt and debris.

Install a new inner element.

Install the outer element.

Install the dust cover [Figure 108].

## FUEL SYSTEM

### Fuel Specifications

Use only clean, high quality diesel fuel, Grade No. 2 or Grade No. 1.

The following is one suggested blending guideline which should prevent fuel gelling during cold temperatures:

TEMPERATURE C° (F°)	NO. 2	NO. 1
-9° (+15°)	100%	0%
Down to -29° (-20°)	50%	50%
Below -29° (-20°)	0%	100%

At a minimum, low sulfur diesel fuel must be used in this machine. Low sulfur is defined as 500 mg/kg (500 ppm) sulfur maximum.

The following fuels may also be used in this machine:

- Ultra low sulfur diesel fuel. Ultra low sulfur is defined as 15 mg/kg (15 ppm) sulfur maximum.
- Biodiesel blend fuel - Must contain no more than five percent biodiesel mixed with low sulfur or ultra low sulfur petroleum based diesel. This is commonly marketed as B5 blended diesel fuel. B5 blended diesel fuel must meet ASTM D975 (US Standard) or EN590 (EU Standard) specifications.

### Biodiesel Blend Fuel

Biodiesel blend fuel has unique qualities that should be considered before using in this machine:

- Cold weather conditions can lead to plugged fuel system components and hard starting.
- Biodiesel blend fuel is an excellent medium for microbial growth and contamination which can cause corrosion and plugging of fuel system components.
- Use of biodiesel blend fuel may result in premature failure of fuel system components, such as plugged fuel filters and deteriorated fuel lines.
- Shorter maintenance intervals may be required, such as cleaning the fuel system and replacing fuel filters and fuel lines.
- Using biodiesel blended fuels containing more than five percent biodiesel can affect engine life and cause deterioration of hoses, tubelines, injectors, injector pump and seals.

Apply the following guidelines if biodiesel blend fuel is used:

- Ensure the fuel tank is as full as possible at all times to prevent moisture from collecting in the fuel tank.
- Ensure that the fuel tank cap is securely tightened.
- Biodiesel blend fuel can damage painted surfaces, remove all spilled fuel from painted surfaces immediately.
- Drain all water from the fuel filter daily before operating the machine.
- Do not exceed engine oil change interval. Extended oil change intervals can cause engine damage.
- Before vehicle storage; drain the fuel tank, refill with 100% petroleum diesel fuel, add fuel stabilizer and run the engine for at least 30 minutes.

**NOTE: Biodiesel blend fuel does not have long term stability and should not be stored for more than three months.**

## FUEL SYSTEM (CONT'D)

### Filling The Fuel Tank

# ! WARNING

## AVOID INJURY OR DEATH

Stop and cool the engine before adding fuel. **NO SMOKING!** Failure to obey warnings can cause an explosion or fire.

W-2063-0807

Figure 111

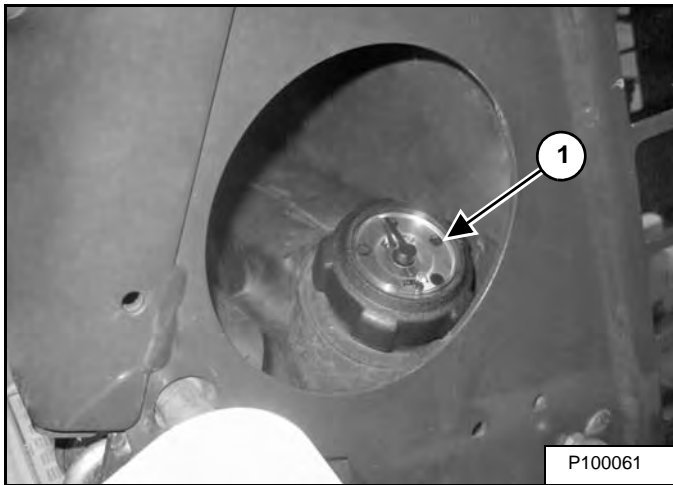

The fuel gauge (Item 1) [Figure 111] is located on the right side of the loader.

Figure 112

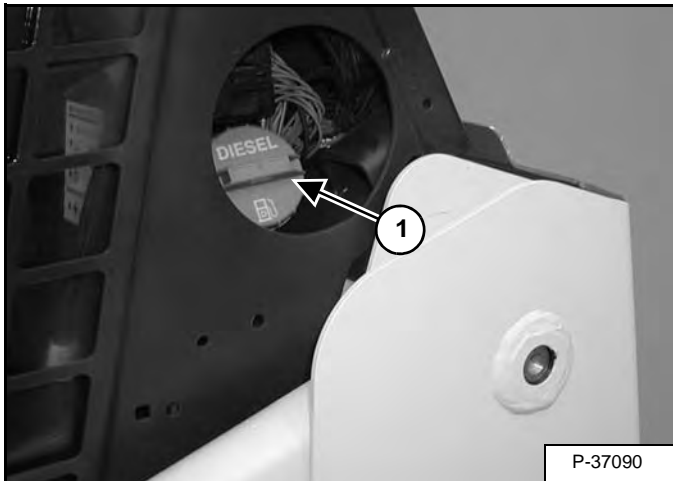

Remove the fill cap (Item 1) [Figure 112].

Figure 113

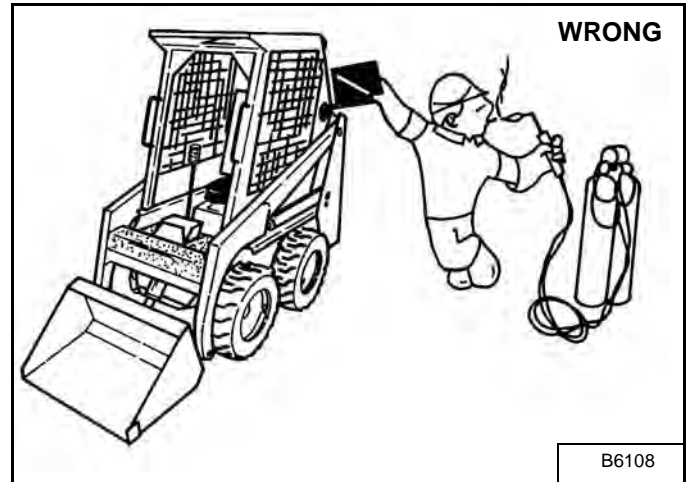

Use a clean, approved safety container to add fuel of the correct specification. Add fuel only in an area that has free movement of air and no open flames or sparks. **NO SMOKING!** [Figure 113].

Install and tighten the fuel fill cap (Item 1) [Figure 112].

# ! WARNING

## AVOID INJURY OR DEATH

Always clean up spilled fuel or oil. Keep heat, flames, sparks or lighted tobacco away from fuel and oil. Failure to use care around combustibles can cause explosion or fire.

W-2103-0508



## FUEL SYSTEM (CONT'D)

### Fuel Filter

For the service interval for removing water from, or replacing the fuel filter (See SERVICE SCHEDULE on Page 71.)

#### Removing Water

Figure 114

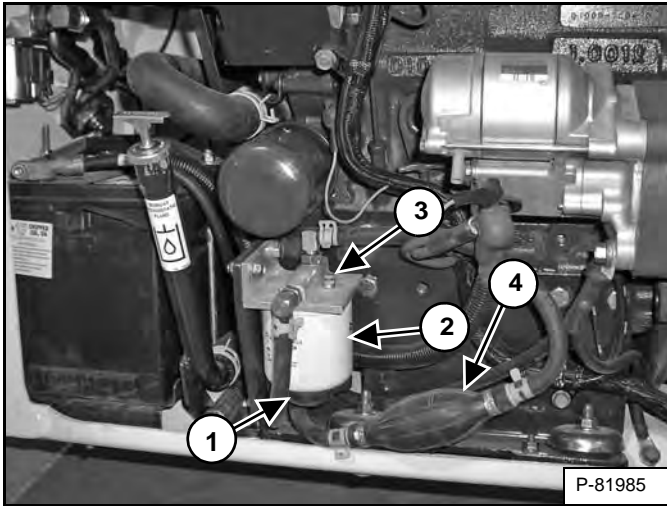

Loosen the drain (Item 1) [Figure 114] at the bottom of the filter element to remove water from the filter.

#### Replacing Element

Remove the filter element (Item 2) [Figure 114].

Clean the area around the filter housing. Put clean oil on the seal of the new filter element. Install the fuel filter, and hand tighten.

Remove air from the fuel system. (See Removing Air From The Fuel System below.)

#### Removing Air From The Fuel System

After replacing the filter element or when the fuel tank has run out of fuel, the air must be removed from the fuel system before starting the engine.

Open the vent (Item 3) [Figure 114] on the fuel filter housing.



#### AVOID INJURY OR DEATH

Diesel fuel or hydraulic fluid under pressure can penetrate skin or eyes, causing serious injury or death. Fluid leaks under pressure may not be visible. Use a piece of cardboard or wood to find leaks. Do not use your bare hand. Wear safety goggles. If fluid enters skin or eyes, get immediate medical attention from a physician familiar with this injury.

W-2072-0807

Squeeze the hand pump (priming bulb) (Item 4) [Figure 114] until there are no air bubbles exiting the vent.

Close the vent (Item 3) [Figure 114] on the fuel filter housing.

With the operator in the seat, seat belt fastened, seat bar lowered and parking brake engaged, start the engine.

**NOTE: If the engine fails to start, remove air from the fuel injection pump as follows.**

Put jackstands under rear of the frame and raise operator cab. (See Raising on Page 80.)

Figure 115

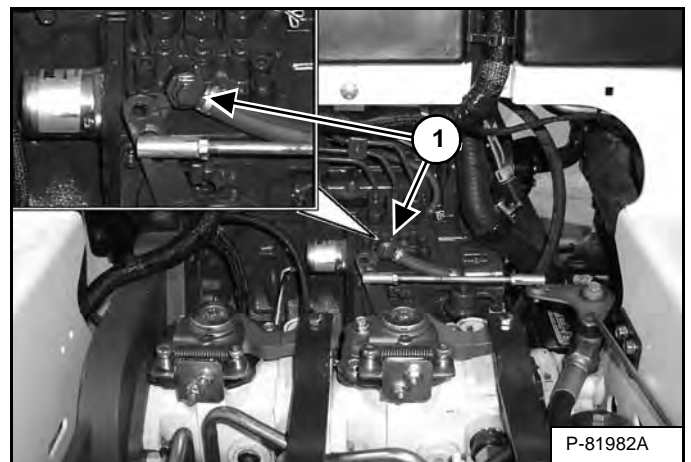

Open the valve (Item 1) [Figure 115] on the injector pump and squeeze the hand pump (Item 4) [Figure 114] several times until fuel comes from the valve.

Close the valve.

Lower the operator cab. (See Lowering on Page 81.)

Remove jackstands.

## ENGINE LUBRICATION SYSTEM

### Checking And Adding Engine Oil

Check the engine oil level every day before starting the engine for the work shift.

**Figure 116**

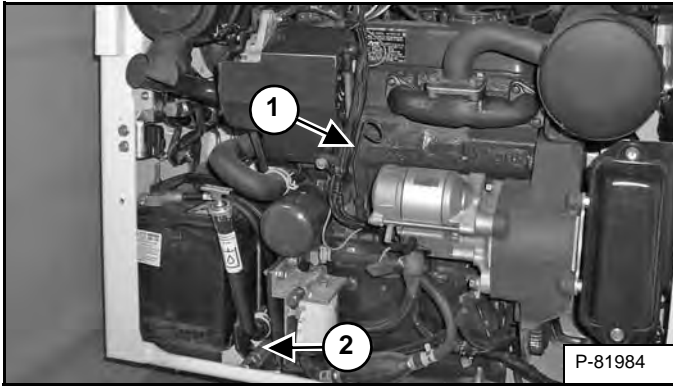

Park the machine on level ground. Open the rear door and remove the dipstick (Item 1) [Figure 116]. Keep the oil level between the marks on the dipstick. Do not overfill.

### Engine Oil Chart

**Figure 117**

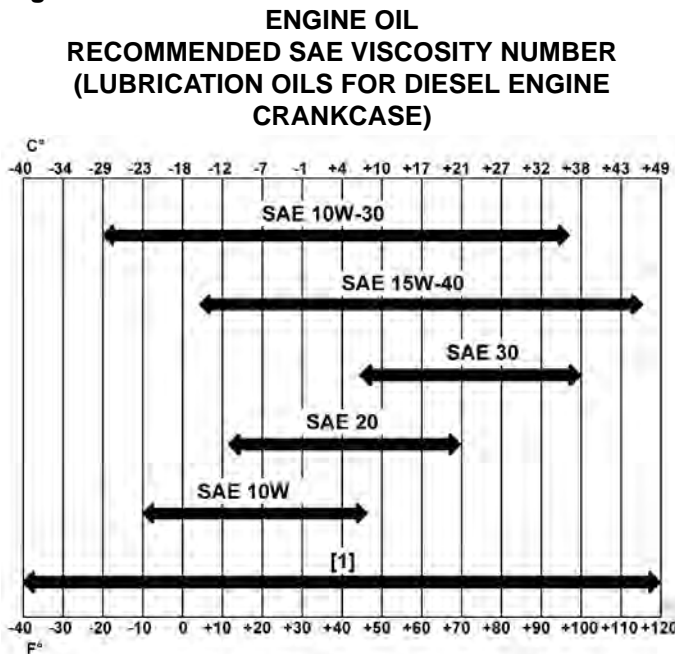

**TEMPERATURE RANGE ANTICIPATED BEFORE NEXT OIL CHANGE (DIESEL ENGINES MUST USE API CLASSIFICATION CI-4 OR BETTER)**

[1] Synthetic Oil - Use recommendation from Synthetic Oil Manufacturer.

Use good quality engine oil that meets API Service Classification of CI-4 or better [Figure 117].

### Removing And Replacing Oil And Filter

For the service interval for replacing the engine oil and filter (See SERVICE SCHEDULE on Page 71.)

Run the engine until it is at operating temperature. Stop the engine.

Open the rear door and remove the drain hose (Item 2) [Figure 116] from its storage position.

**Figure 118**

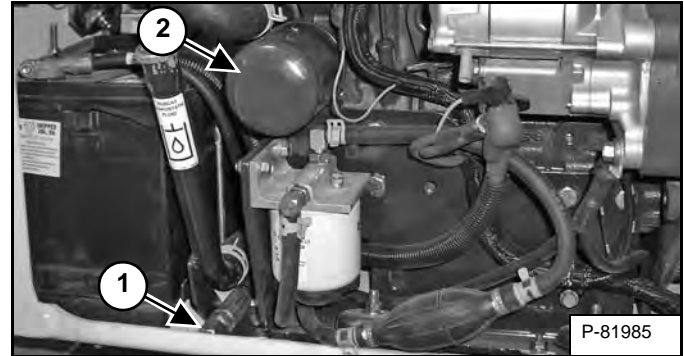

Remove the oil drain cap (Item 1) [Figure 118] and drain the oil into a container. Recycle or dispose of used oil in an environmentally safe manner.

Remove the oil filter (Item 2) [Figure 118] and clean the filter housing surface.

Use genuine Bobcat filter only. Put oil on the new filter gasket, install the filter and hand tighten.

Install and tighten the oil drain cap and return the drain hose to the stored position.

Remove the fill cap and put oil in the engine. For the correct quantity (See Capacities on Page 132.) Do not overfill.

Start the engine and let it run for several minutes. Stop the engine and check for leaks at the filter.

Add oil as needed if it is not at the top mark on the dipstick. Install the dipstick and close the rear door.



### AVOID INJURY OR DEATH

**Always clean up spilled fuel or oil. Keep heat, flames, sparks or lighted tobacco away from fuel and oil. Failure to use care around combustibles can cause explosion or fire.**

W-2103-0508

## ENGINE COOLING SYSTEM

Check the cooling system every day to prevent over-heating, loss of performance or engine damage.

### Cleaning

Open the rear door.

Figure 119

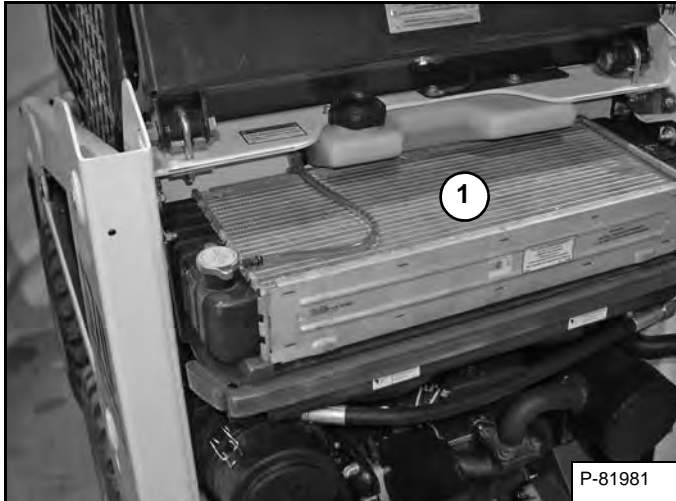

Use low air pressure or water pressure to clean the top of the radiator (Item 1) [Figure 119].

Check the cooling system for leaks.

Close the rear door.

### Checking Level

Open the rear door.

## **WARNING**

### AVOID INJURY OR DEATH

Wear safety glasses to prevent eye injury when any of the following conditions exist:

- When fluids are under pressure.
- Flying debris or loose material is present.
- Engine is running.
- Tools are being used.

W-2019-0907

Figure 120

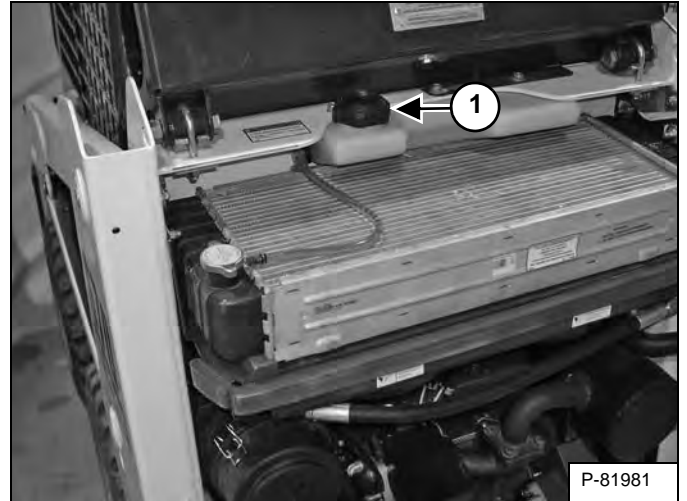

Remove the coolant fill cap (Item 1) [Figure 120]. Check the coolant level. The level markers are on the tank. Coolant must be at the bottom marker when the engine is cold and on the top marker when hot.

Use a refractometer to check the condition of propylene glycol in your cooling system.

Close the rear door before operating the loader.

## **IMPORTANT**

### AVOID ENGINE DAMAGE

Always use the correct ratio of water to antifreeze.

Too much antifreeze reduces cooling system efficiency and may cause serious premature engine damage.

Too little antifreeze reduces the additives which protect the internal engine components; reduces the boiling point and freeze protection of the system.

Always add a premixed solution. Adding full strength concentrated coolant can cause serious premature engine damage.

I-2124-0497

## ENGINE COOLING SYSTEM (CONT'D)

### Removing And Replacing Coolant

Open the rear door.

Figure 121

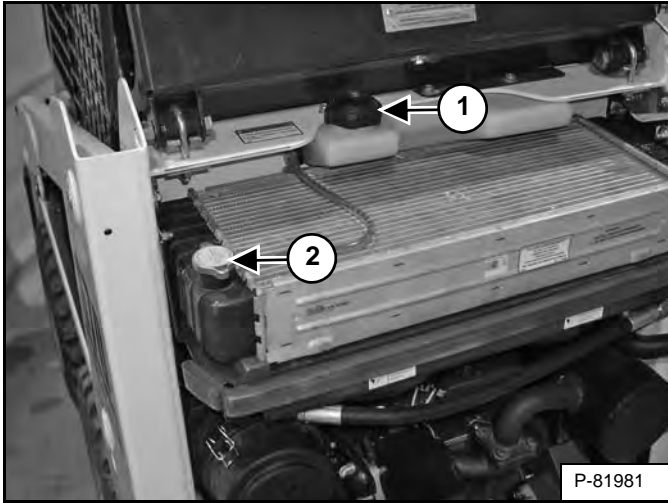

Remove the coolant fill cap (Item 1) [Figure 121].

Figure 122

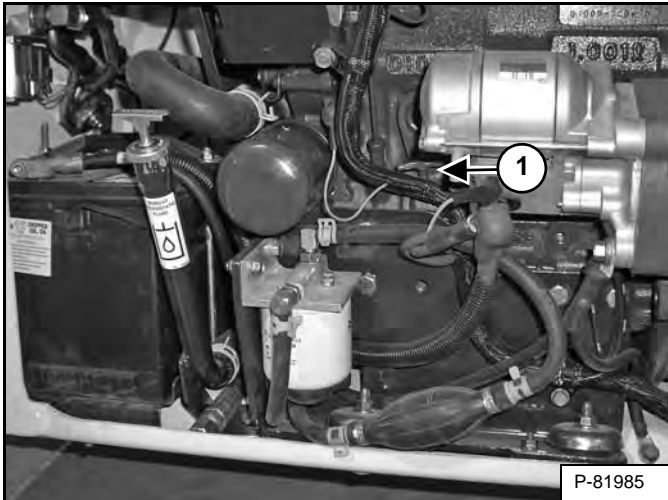

Connect a hose to the engine block drain valve (Item 1) [Figure 122] (located below the starter). Open the drain valve and drain the coolant into a container.

After all the coolant is removed, close the drain valve and remove the hose.

**NOTE:** Fluids such as engine oil, hydraulic fluid, coolant, etc. must be disposed of in an environmentally safe manner. Some regulations require that certain spills and leaks on the ground must be cleaned in a specific manner. See local, state and federal regulations for correct disposal.

Mix new coolant in a separate container. (See Capacities on Page 132.)

**NOTE:** The loader is factory filled with propylene glycol coolant (purple color). **DO NOT** mix propylene glycol with ethylene glycol.

Remove the radiator cap (Item 2) [Figure 121] and fill the radiator with premixed coolant, 47% water and 53% propylene glycol. Reinstall the radiator cap.

The correct mixture of coolant to provide a -37°C (-34°F) freeze protection is 5 L propylene glycol mixed with 4,4 L of water **OR** 1 U.S. gal propylene glycol mixed with 3.5 qt of water.

Fill the recovery tank with premixed coolant until it is at the lower marker on the tank.

Use a refractometer to check the condition of propylene glycol in your cooling system and replace the coolant fill cap (Item 1) [Figure 121].

Run the engine until it is at operating temperature. After stopping the engine, let it cool down and check the coolant level again. Add coolant as needed.

Close the rear door.

## IMPORTANT

### AVOID ENGINE DAMAGE

Always use the correct ratio of water to antifreeze.

Too much antifreeze reduces cooling system efficiency and may cause serious premature engine damage.

Too little antifreeze reduces the additives which protect the internal engine components; reduces the boiling point and freeze protection of the system.

Always add a premixed solution. Adding full strength concentrated coolant can cause serious premature engine damage.

I-2124-0497

## ELECTRICAL SYSTEM

### Description

The loader has a 12 volt, negative ground alternator charging system. The electrical system is protected by fuses located in the engine compartment. The fuses will protect the electrical system when there is an electrical overload. The reason for the overload must be found before starting the engine again.

### Fuse And Relay Location / Identification

Figure 123

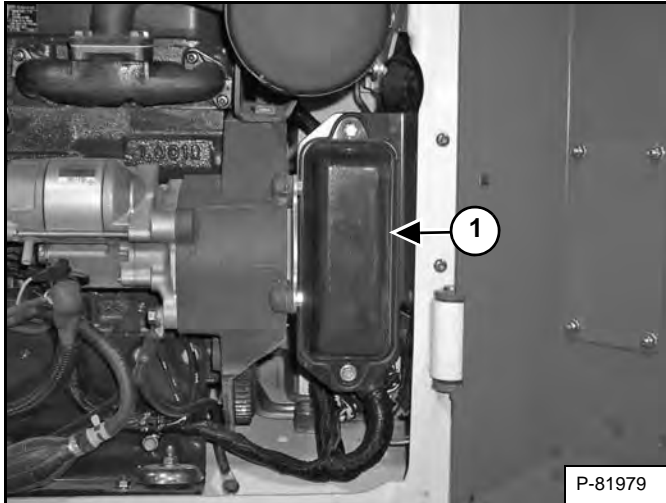

The electrical system is protected from overload by fuses and relays under the fuse panel cover (Item 1) [Figure 123]. A decal is inside the cover to show location and amperage ratings.

Figure 124



Remove the cover to check or replace the fuses [Figure 124].

Figure 125

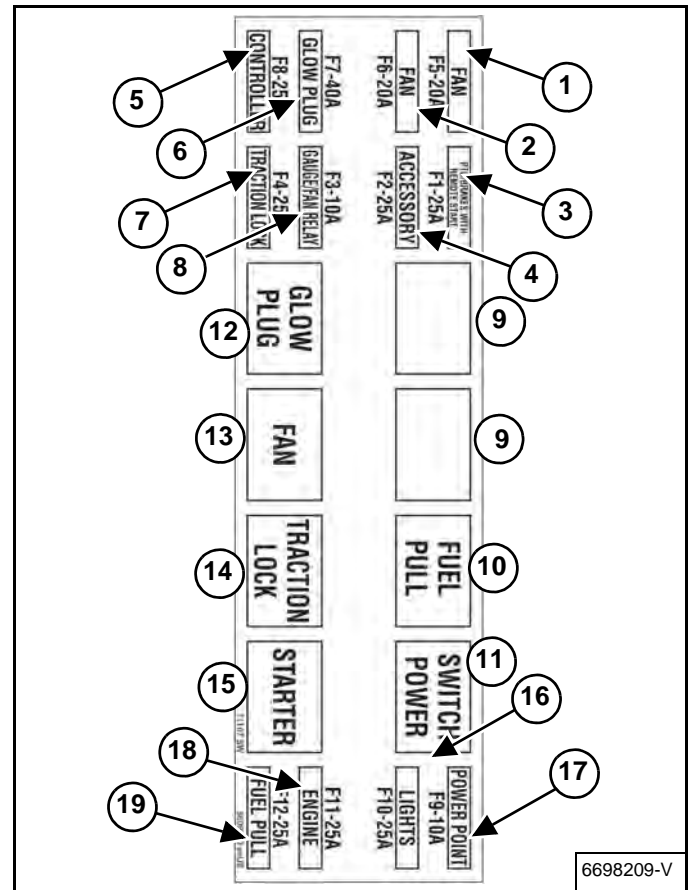

There is a decal [Figure 125] inside the fuse panel cover which shows location and size of fuses. Description and amperage ratings (or relays) are also shown below.

REF.	DESCRIPTION	AMPS	REF.	DESCRIPTION	AMPS
1	Fan	20	10	Fuel Solenoid	R
2	Fan	20	11	Switched Power	R
3	BICS / Brakes / Remote Start	25	12	Glow Plug	R
4	Accessory Back-up Alarm	25	13	Fan	R
5	Controller	25	14	Traction Lock	R
6	Glow Plug	40	15	Starter	R
7	Traction Lock	25	16	Lights	25
8	Gauge / Fan Relay	10	17	Power Point	10
9	Not Used	R	18	Engine / Horn	25
			19	Fuel Solenoid	25

R = Relay

## ELECTRICAL SYSTEM (CONT'D)

### Battery Maintenance

Figure 126

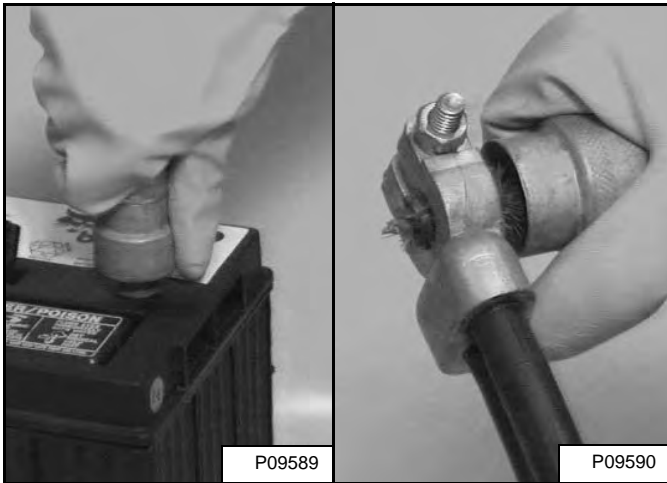

The battery cables must be clean and tight [Figure 126]. Check electrolyte level in the battery. Add distilled water as needed. Remove acid or corrosion from battery and cables with sodium bicarbonate (baking soda) and water solution.

Put Battery Saver (6988074) or grease on the battery terminals and cable ends to prevent corrosion.

## WARNING

### AVOID INJURY OR DEATH

Batteries contain acid which burns eyes and skin on contact. Wear goggles, protective clothing and rubber gloves to keep acid off body.

In case of acid contact, wash immediately with water. In case of eye contact get prompt medical attention and wash eye with clean, cool water for at least 15 minutes.

If electrolyte is taken internally drink large quantities of water or milk! DO NOT induce vomiting. Get prompt medical attention.

W-2065-0807

### Using A Booster Battery (Jump Starting)

If it is necessary to use a booster battery to start the engine, BE CAREFUL! There must be one person in the operator's seat and one person to connect and disconnect the battery cables.

Figure 127

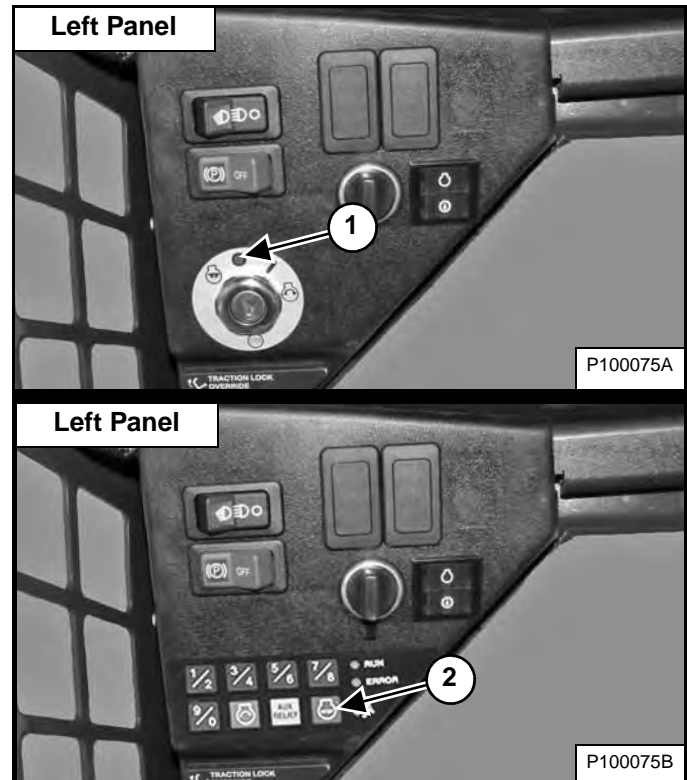

The key switch (Item 1) must be in the OFF position or the STOP button (Item 2) [Figure 127] must be pressed. The booster battery must be 12 volt.

## WARNING

### BATTERY GAS CAN EXPLODE AND CAUSE SERIOUS INJURY OR DEATH

Keep arcs, sparks, flames and lighted tobacco away from batteries. When *jumping* from booster battery make final connection (negative) at machine frame.

Do not jump start or charge a frozen or damaged battery. Warm battery to 16°C (60°F) before connecting to a charger. Unplug charger before connecting or disconnecting cables to battery. Never lean over battery while boosting, testing or charging.

W-2066-0910

## ELECTRICAL SYSTEM (CONT'D)

### Using A Booster Battery (Jump Starting) (Cont'd)

# ! WARNING

#### AVOID INJURY OR DEATH

Batteries contain acid which burns eyes and skin on contact. Wear goggles, protective clothing and rubber gloves to keep acid off body.

In case of acid contact, wash immediately with water. In case of eye contact get prompt medical attention and wash eye with clean, cool water for at least 15 minutes.

If electrolyte is taken internally drink large quantities of water or milk! DO NOT induce vomiting. Get prompt medical attention.

W-2065-0807

Figure 128

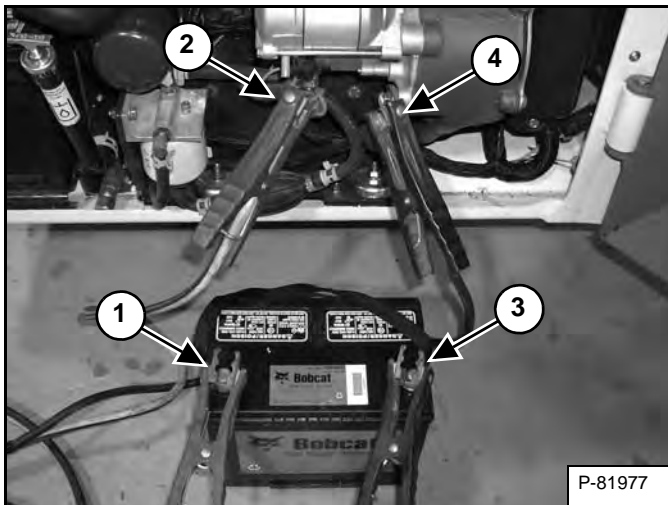

Connect the end of the first cable to the positive (+) terminal (Item 1) of the booster battery. Connect the other end of the same cable to the positive terminal (Item 2) [Figure 128] on the loader starter.

Connect the end of the second cable to the negative (-) terminal (Item 3) of the booster battery. Connect the other end of the same cable (Item 4) [Figure 128] to the engine.

**NOTE: Keep cables away from moving parts.**

Start the engine. (See STARTING THE ENGINE on Page 48.)

After the engine has started, remove the negative (-) cable (Item 4) [Figure 128] first.

Remove the cable from the positive terminal (Item 2) [Figure 128].

# IMPORTANT

Damage to the alternator can occur if:

- Engine is operated with battery cables disconnected.
- Battery cables are connected when using a fast charger or when welding on the loader. (Remove both cables from the battery.)
- Extra battery cables (booster cables) are connected wrong.

I-2023-1285

## ELECTRICAL SYSTEM (CONT'D)

### Removing And Installing Battery

# ! WARNING

### AVOID INJURY OR DEATH

Batteries contain acid which burns eyes and skin on contact. Wear goggles, protective clothing and rubber gloves to keep acid off body.

In case of acid contact, wash immediately with water. In case of eye contact get prompt medical attention and wash eye with clean, cool water for at least 15 minutes.

If electrolyte is taken internally drink large quantities of water or milk! DO NOT induce vomiting. Get prompt medical attention.

W-2065-0807

Open the rear door.

Figure 129

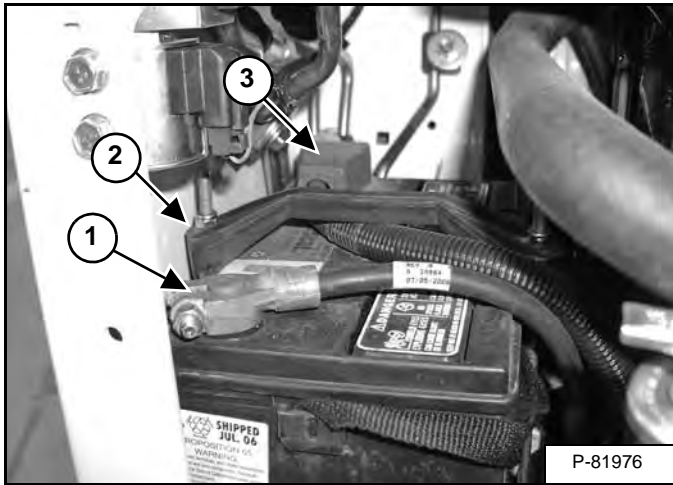

Disconnect the negative (-) battery cable (Item 1) [Figure 129].

Remove the battery hold-down clamp (Item 2) [Figure 129].

Disconnect the positive (+) cable (Item 3) [Figure 129] from the battery.

Remove the battery from the loader.

**NOTE:** When removing or installing the battery in the loader, do not touch any metal parts with the battery terminals.

Figure 130

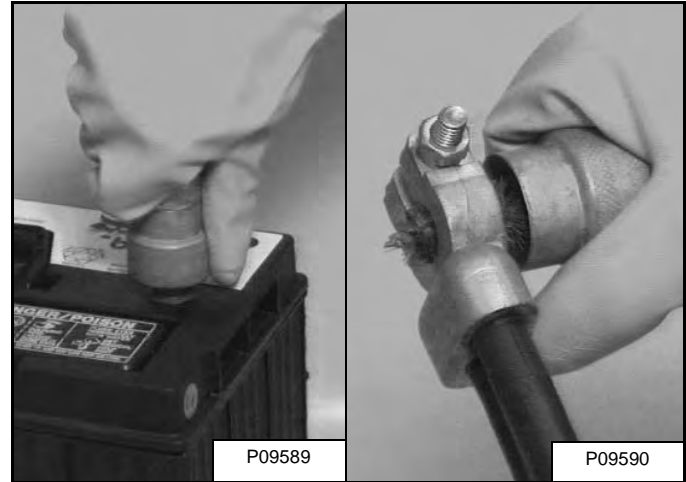

Always clean the battery terminals and cable ends when installing a new or used battery [Figure 130].

**NOTE:** Always connect the negative (-) cable last and remove it first to prevent sparks.

Connect the positive (+) battery cable.

Install and tighten the battery hold-down clamp.

Connect the negative (-) battery cable.

Close the rear door before operating the loader.



## HYDRAULIC / HYDROSTATIC SYSTEM

### Checking And Adding Fluid

Check the hydraulic / hydrostatic fluid level every day before starting the work shift.

Park the loader on a level surface.

Lower the lift arms and tilt the Bob-Tach fully back.

Stop the engine and exit the loader. (See STOPPING THE ENGINE AND LEAVING THE LOADER on Page 53.)

Figure 131

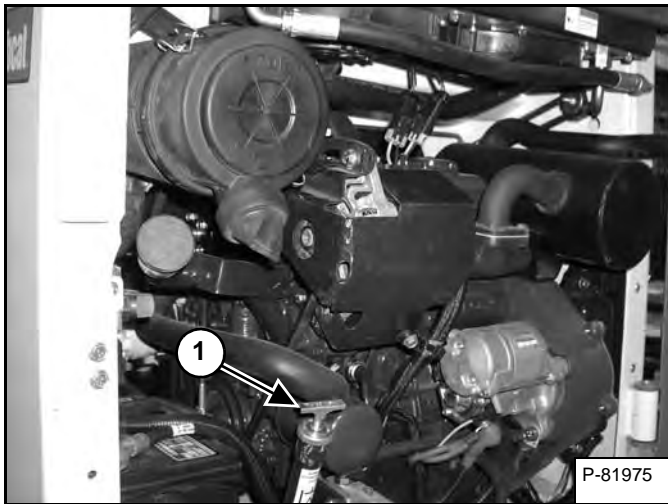

Remove the dipstick (Item 1) [Figure 131] and allow the oil level to stabilize for 10 - 15 seconds. Install the dipstick and remove to check the fluid level.

**NOTE:** Hydraulic oil level in the dipstick tube must be allowed to stabilize before it is checked or the dipstick may incorrectly indicate a low fluid condition.

If fluid is needed, add fluid through the dipstick / fill tube.

### Hydraulic / Hydrostatic Fluid Chart

Figure 132

#### HYDRAULIC / HYDROSTATIC FLUID RECOMMENDED ISO VISCOSITY GRADE (VG) AND VISCOSITY INDEX (VI)

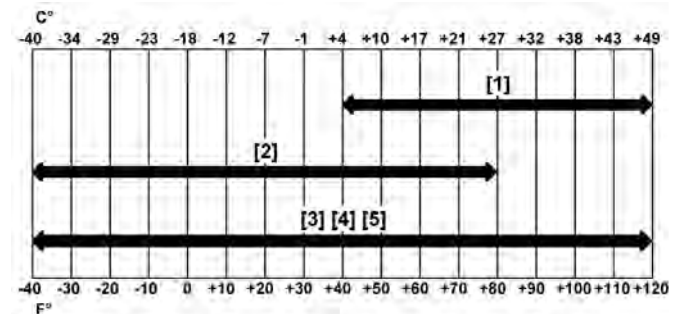

#### TEMPERATURE RANGE ANTICIPATED DURING MACHINE USE

- [1] VG 100; Minimum VI 130
- [2] VG 46; Minimum VI 150
- [3] BOBCAT All-Season Fluid
- [4] BOBCAT Synthetic Fluid
- [5] BOBCAT Biodegradable Hydraulic / Hydrostatic Fluid (Unlike biodegradable fluids that are vegetable based, Bobcat biodegradable fluid is formulated to prevent oxidation and thermal breakdown at operating temperatures.)

Use only recommended fluid in the hydraulic system [Figure 132]. (See Hydraulic System on Page 131.)

## HYDRAULIC / HYDROSTATIC SYSTEM (CONT'D)

### Removing And Replacing Hydraulic Fluid

For the correct service interval (See SERVICE SCHEDULE on Page 71.)

Replace the fluid if it becomes contaminated or after major repair.

Always replace the hydraulic / hydrostatic filter whenever the hydraulic fluid is replaced. (See Removing And Replacing Hydraulic / Hydrostatic Filter on Page 97.)

**Figure 133**

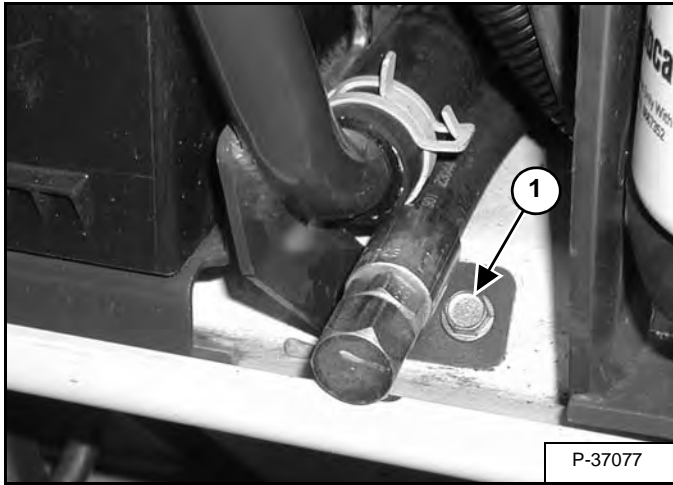

Remove the bolt (Item 1) [Figure 133] from the dipstick / fill tube mounting bracket.

**Figure 134**



Remove the dipstick from the hydraulic fill tube and rotate the tube down into a container [Figure 134] to drain the reservoir.

**NOTE:** Fluids such as engine oil, hydraulic fluid, coolant, etc. must be disposed of in an environmentally safe manner. Some regulations require that certain spills and leaks on the ground must be cleaned in a specific manner. See local, state and federal regulations for correct disposal.

After the hydraulic fluid is completely drained, rotate the hydraulic fill tube back to the original position and reinstall the bolt (Item 1) [Figure 133] to the fill tube mounting bracket.

Fill the hydraulic system with the correct amount and type of hydraulic fluid. (See Hydraulic / Hydrostatic Fluid Chart on Page 95.) and (See Capacities on Page 132.)

## HYDRAULIC / HYDROSTATIC SYSTEM (CONT'D)

### Removing And Replacing Hydraulic / Hydrostatic Filter

For the correct service interval (See SERVICE SCHEDULE on Page 71.)

Stop the engine and exit the loader. (See STOPPING THE ENGINE AND LEAVING THE LOADER on Page 53.)

Raise the operator cab. (See Raising on Page 80.)

Figure 135

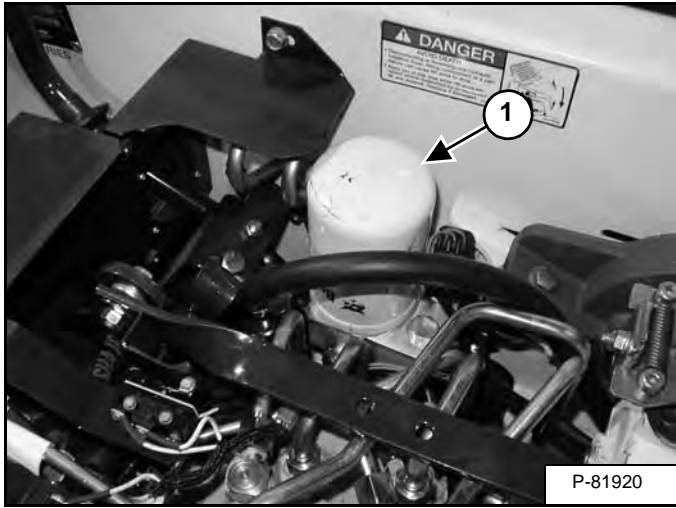

Remove the filter (Item 1) [Figure 135].

Clean the surface of the filter housing where the filter seal contacts the housing.

Put clean oil on the seal of the new filter element. Install and hand tighten the filter element.

## WARNING

### AVOID INJURY OR DEATH

Always clean up spilled fuel or oil. Keep heat, flames, sparks or lighted tobacco away from fuel and oil. Failure to use care around combustibles can cause explosion or fire.

W-2103-0508

Lower the operator cab. (See Lowering on Page 81.)

Start the engine and operate the loader hydraulic controls.

Stop the engine and exit the loader. (See STOPPING THE ENGINE AND LEAVING THE LOADER on Page 53.)

Check for leaks at the filter.

## WARNING

### AVOID INJURY OR DEATH

Diesel fuel or hydraulic fluid under pressure can penetrate skin or eyes, causing serious injury or death. Fluid leaks under pressure may not be visible. Use a piece of cardboard or wood to find leaks. Do not use your bare hand. Wear safety goggles. If fluid enters skin or eyes, get immediate medical attention from a physician familiar with this injury.

W-2072-0807

Check fluid level and add as needed. (See Checking And Adding Fluid on Page 95.)

### Breather Cap

Replace the breather cap at the correct service interval. (See SERVICE SCHEDULE on Page 71.)

Raise the cab. (See Raising on Page 80.)

Figure 136

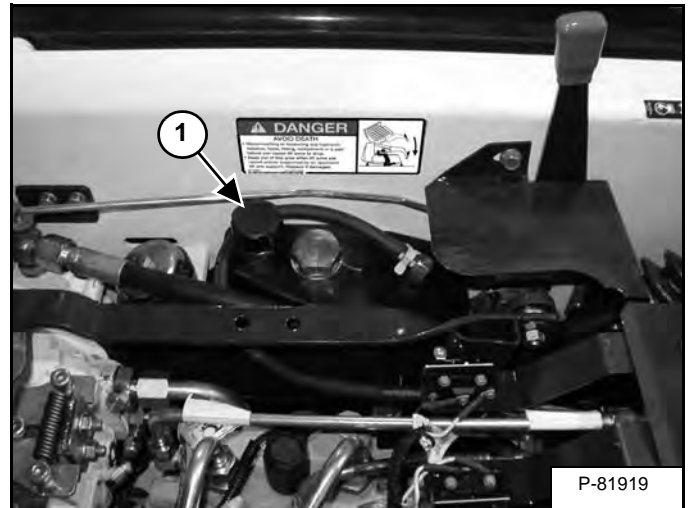

Thoroughly clean the area around the breather cap.

Remove the breather cap (Item 1) [Figure 136] and discard.

Install new breather cap.

Lower the cab. (See Lowering on Page 81.)

## SPARK ARRESTER MUFFLER

### Cleaning Procedure

See the SERVICE SCHEDULE for service interval for cleaning the spark arrester muffler. (See SERVICE SCHEDULE on Page 71.)

Do not operate the loader with a defective exhaust system.

## IMPORTANT

This machine is factory equipped with a U.S.D.A. Forestry Service approved spark arrester exhaust system.

The spark arrester muffler, if equipped, must be cleaned to keep it in working condition. The spark arrester muffler must be serviced by dumping the spark chamber every 100 hours of operation.

On some models, the turbocharger functions as the spark arrester and must operate correctly for proper spark arrester function.

If this machine is operated on flammable forest, brush, or grass covered land, it must be equipped with a spark arrester attached to the exhaust system and maintained in working order. Failure to do so will be in violation of California State Law, Section 4442. PRC. Refer to local laws and regulations for spark arrester requirements.

I-2284-0111

Stop the engine and exit the loader. (See STOPPING THE ENGINE AND LEAVING THE LOADER on Page 53.) Open the rear door.

Figure 137

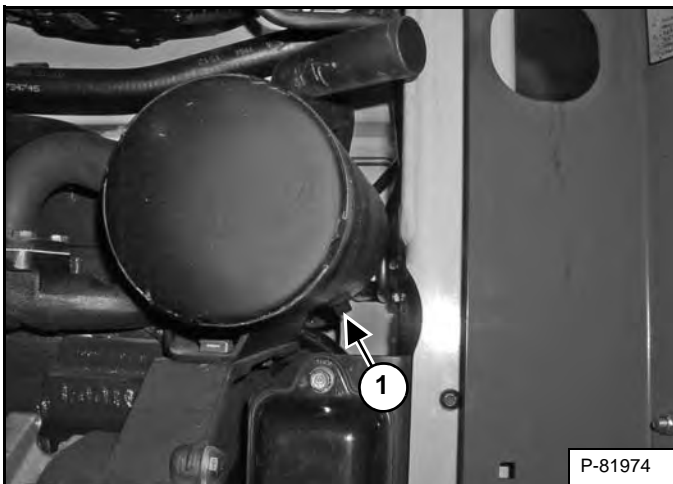

Remove the plug (Item 1) [Figure 137] from the bottom of the muffler.

## ! WARNING

When the engine is running during service, the driving and steering controls must be in neutral and the parking brake engaged. Failure to do so can cause injury or death.

W-2006-1209

Start the engine and run for about 10 seconds while a second person, wearing safety goggles, holds a piece of wood over the outlet of the muffler. This will force contaminants out through the cleanout hole.

Stop the engine and exit the loader. (See STOPPING THE ENGINE AND LEAVING THE LOADER on Page 53.)

Install and tighten the plug. Close the rear door.

## ! WARNING

### AVOID INJURY OR DEATH

When an engine is running in an enclosed area, fresh air must be added to avoid concentration of exhaust fumes. If the engine is stationary, vent the exhaust outside. Exhaust fumes contain odorless, invisible gases which can kill without warning.

W-2050-0807

## ! WARNING

Stop engine and allow the muffler to cool before cleaning the spark chamber. Wear safety goggles. Failure to obey can cause serious injury.

W-2011-1285

## ! WARNING

Never use machine in atmosphere with explosive dust or gases or where exhaust can contact flammable material. Failure to obey warnings can cause injury or death.

W-2068-1285

## TIRE MAINTENANCE

### Wheel Nuts

Figure 138



See the SERVICE SCHEDULE for the service interval to check the wheel nuts [Figure 138]. (See SERVICE SCHEDULE on Page 71.)

When *installing* wheel nuts, tighten to 217 N•m (160 ft-lb) torque.

When *checking* wheel nut torque, set the torque wrench to 190 N•m (140 ft-lb) to prevent over-tightening.

### Rotating

Check the tires regularly for wear, damage and pressure. Inflate tires to the maximum pressure shown on the sidewall of the tire.

Figure 139

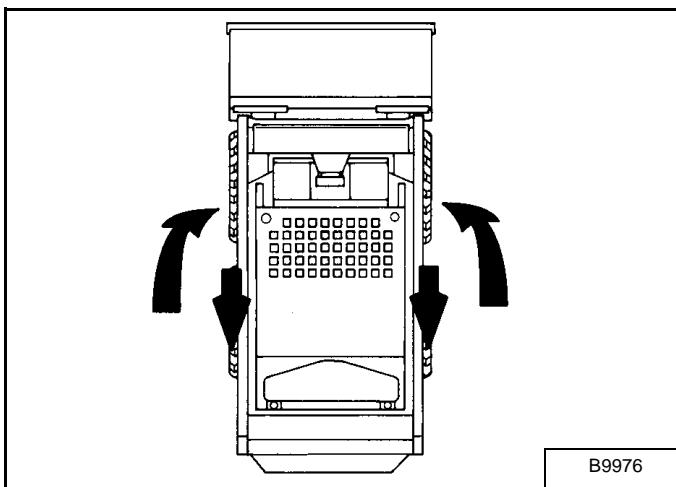

Rear tires usually wear faster than front tires. To keep tire wear even, move the front tires to the rear and rear tires to the front [Figure 139].

It is important to keep all tires the same size. If different sizes are used, each tire will be turning at a different rate and cause excessive wear. The tread bars of all the tires must face the same direction.

Recommended tire pressure must be maintained to avoid excessive tire wear and loss of stability and handling capability. Check for the correct pressure before operating the loader.

### Mounting

Tires are to be repaired only by an authorized person using the proper procedures and safe equipment.

Tires and rims must always be checked for correct size before mounting. Check rim and tire bead for damage.

The rim flange must be cleaned and free of rust.

The tire bead and rim flange must be lubricated with a rubber lubricant before mounting the tire.

Avoid excessive pressure which can rupture the tire and cause serious injury or death.

During inflation of the tire, check the tire pressure frequently to avoid over inflation.

## **WARNING**

### **AVOID INJURY OR DEATH**

**Do not inflate tires above specified pressure. Failure to use correct tire mounting procedure can cause an explosion which can result in injury or death.**

W-2078-1007

## **IMPORTANT**

**Inflate tires to the MAXIMUM pressure shown on the sidewall of the tire. DO NOT mix brands of tires used on the same machine.**

I-2057-1010

## FINAL DRIVE TRANSMISSION (CHAINCASE)

### Checking And Adding Oil

The chaincase contains the final drive sprockets and chains. Use the same type of oil as the hydraulic / hydrostatic system.

Park the loader on a level surface.

Stop the engine and exit the loader. (See STOPPING THE ENGINE AND LEAVING THE LOADER on Page 53.)

Install jackstands under the rear corners of the loader frame.

Enter the loader and raise the loader lift arms. Install the Lift Arm Support Device. (See LIFT ARM SUPPORT DEVICE on Page 76.)

Stop the engine and exit the loader. (See STOPPING THE ENGINE AND LEAVING THE LOADER on Page 53.)

**Figure 140**

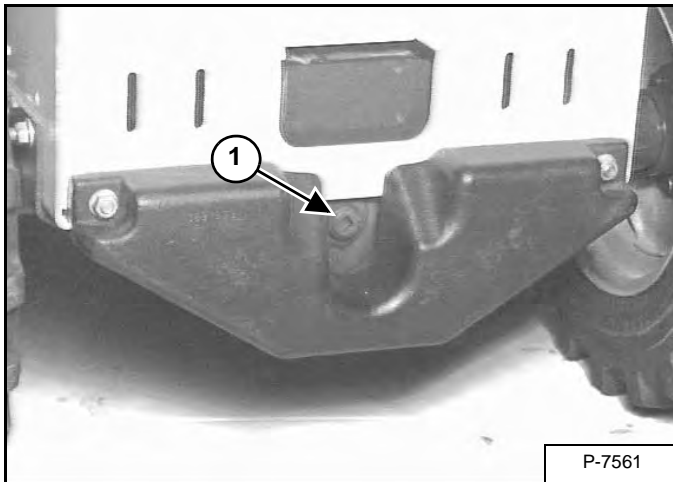

Remove the check plug (Item 1) **[Figure 140]** from the front of the chaincase housing.

If oil can be reached with the tip of your finger through the hole, the oil level is correct.

If the level is low, add lubricant through the check plug hole until the oil flows from the hole.

Install and tighten the plug.

Lower the lift arms. (See LIFT ARM SUPPORT DEVICE on Page 76.)

Remove jackstands.

### Removing And Replacing Oil

Park the loader on a level surface.

Stop the engine and exit the loader. (See STOPPING THE ENGINE AND LEAVING THE LOADER on Page 53.)

Install jackstands under the rear corners of the loader frame.

Enter the loader and raise the loader lift arms. Install the Lift Arm Support Device. (See LIFT ARM SUPPORT DEVICE on Page 76.)

Stop the engine and exit the loader. (See STOPPING THE ENGINE AND LEAVING THE LOADER on Page 53.)

Remove the check plug (Item 1) **[Figure 140]** from the front of the chaincase housing.

**Figure 141**

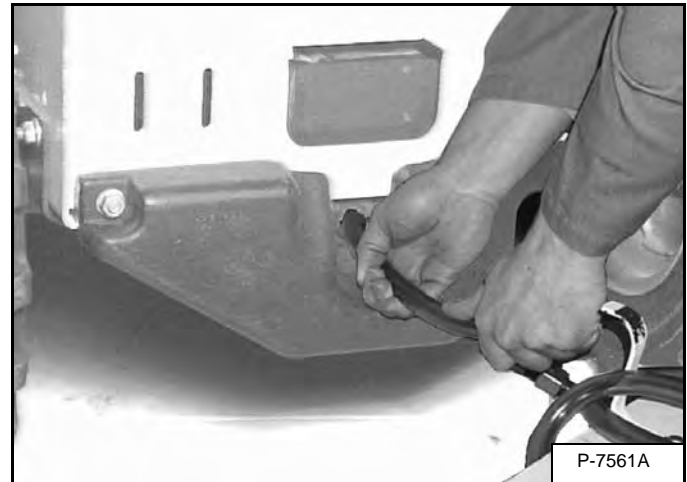

Use a pump to suction the oil from the chaincase **[Figure 141]**.

Recycle or dispose of the used oil in an environmentally safe manner.

Add new oil until the oil flows from the hole.

Install and tighten the plug.

Lower the lift arms. (See LIFT ARM SUPPORT DEVICE on Page 76.)

Remove jackstands.

## ALTERNATOR BELT

### Belt Adjustment

Stop the engine and exit the loader. (See STOPPING THE ENGINE AND LEAVING THE LOADER on Page 53.)

Open the rear door. (See REAR DOOR (TAILGATE) on Page 83.)

**Figure 142**

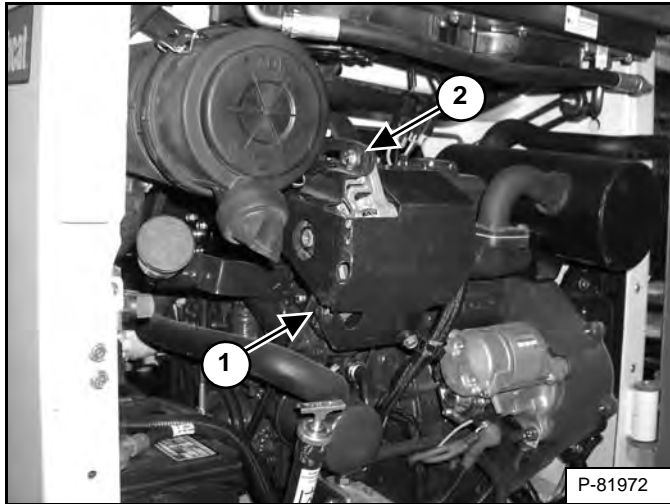

Loosen the alternator mounting bolt (Item 1) **[Figure 142]**.

Loosen the adjustment bolt (Item 2) **[Figure 142]**.

The tension is correct with 6 mm (1/4 in) belt movement at mid span when 67 N (15 lb) force is applied to the belt.

Tighten the adjustment bolt and mounting bolt.

Close the rear door.

### Belt Replacement

Stop the engine and exit the loader. (See STOPPING THE ENGINE AND LEAVING THE LOADER on Page 53.)

Open the rear door. (See REAR DOOR (TAILGATE) on Page 83.)

Loosen the alternator mounting and adjustment bolts (Items 1 and 2) **[Figure 142]** and loosen the belt all the way.

Remove the belt and install a new belt.

The tension is correct with 6 mm (1/4 in) belt movement at mid span when 67 N (15 lb) force is applied to the belt.

Tighten the adjustment bolt and mounting bolt.

Close the rear door.

## DRIVE BELT

### Belt Adjustment

The drive belt does not need adjustment. The belt has a spring loaded idler which is constantly adjusted.

### Belt Replacement

Stop the engine and exit the loader. (See STOPPING THE ENGINE AND LEAVING THE LOADER on Page 53.)

Open the rear door and disconnect the negative (-) cable from the battery.

**Figure 143**

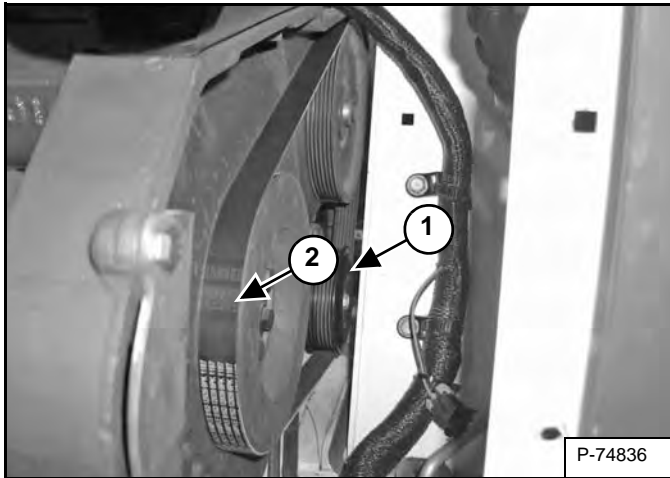

Use a socket wrench (without socket) to move the spring loaded belt tensioner (Item 1) **[Figure 143]** upward.

While holding the spring loaded belt tensioner up, you can remove the drive belt (Item 2) **[Figure 143]**.

Carefully lower the spring loaded belt tensioner to its stop.

Install a new drive belt by reversing the above procedure.



## LUBRICATING THE LOADER

### Lubrication Locations

Lubricate the loader as specified for the best performance of the loader. (See SERVICE SCHEDULE on Page 71.)

Record the operating hours each time you lubricate the Bobcat Loader.

Always use a good quality lithium based multipurpose grease when you lubricate the loader. Apply the lubricant until extra grease shows.

Lubricate the following locations on the loader:

**Figure 144**

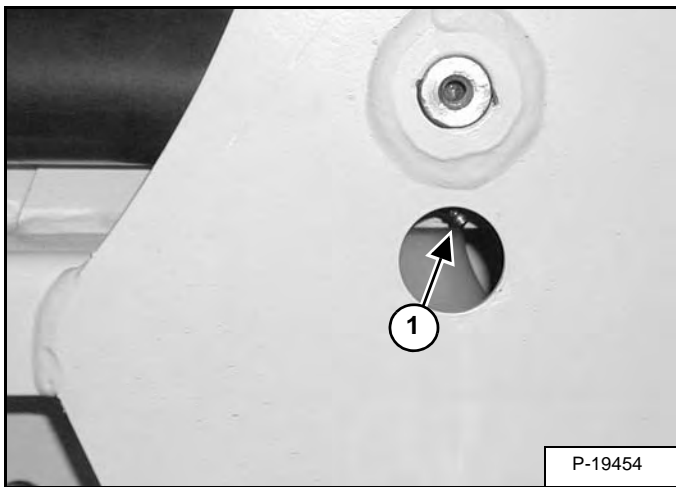

1. Base End Lift Cylinder (Both Sides) [Figure 144].

**Figure 145**

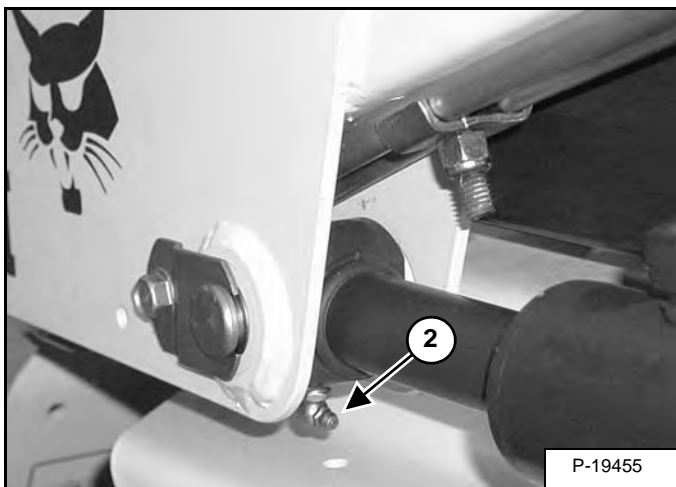

2. Rod End Lift Cylinder (Both Sides) [Figure 145].

**Figure 146**

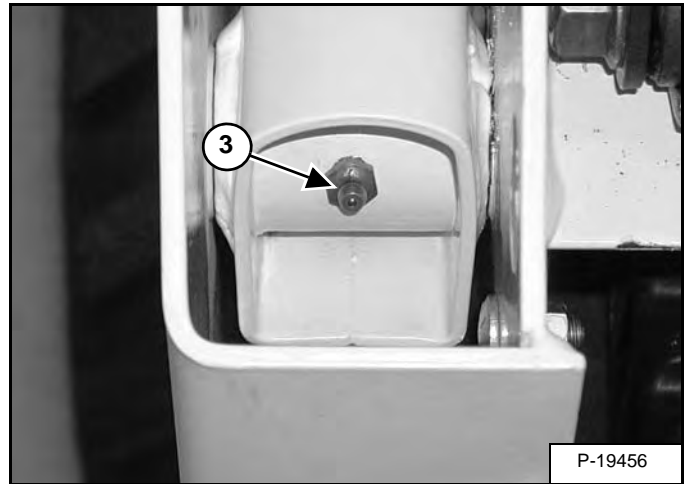

3. Lift Arm Pivot Pin (Both Sides) [Figure 146].

**Figure 147**

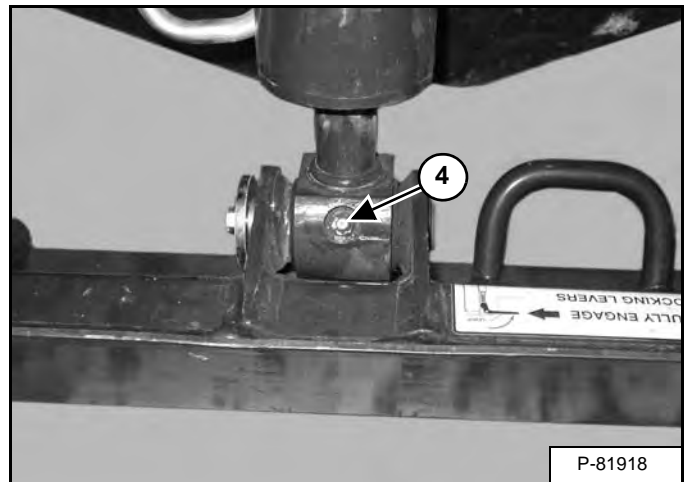

4. Rod End Tilt Cylinder [Figure 147].

## LUBRICATING THE LOADER (CONT'D)

### Lubrication Locations (Cont'd)

Figure 148

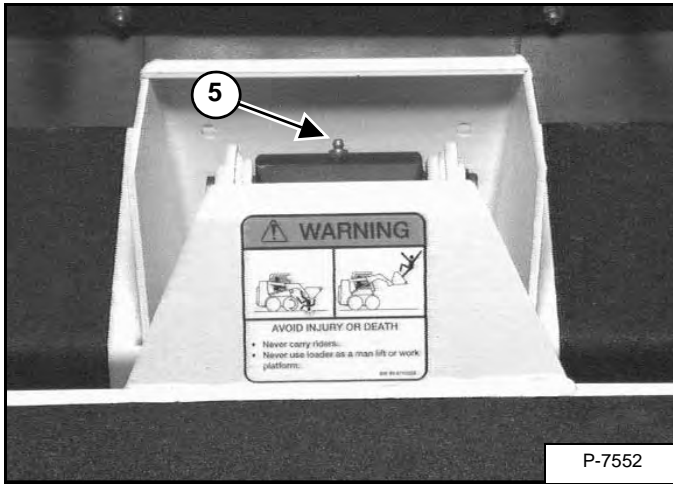

5. Base End Tilt Cylinder [Figure 148].

Figure 149

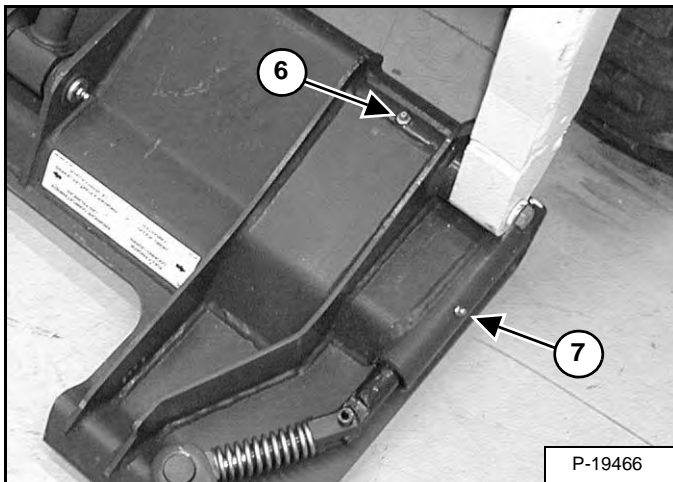

6. Bob-Tach Pivot Pin (Both Sides) [Figure 149].  
7. Bob-Tach Wedge (Both Sides) [Figure 149].

Figure 150

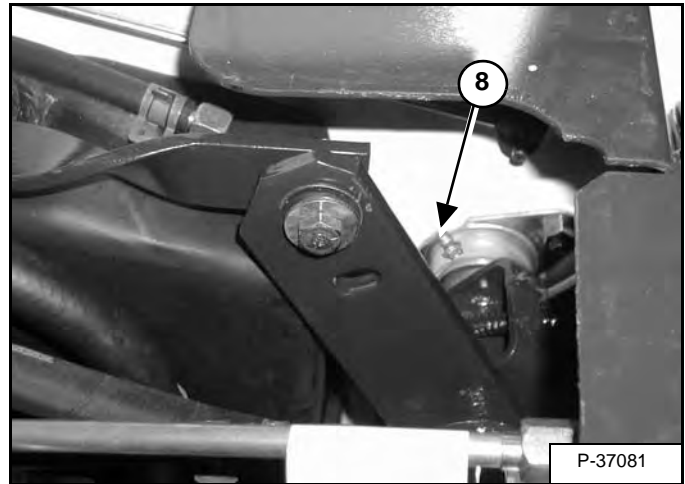

8. 250 Hours: Steering shaft pivot bearings (Both Sides) [Figure 150].

## PIVOT PINS

### Inspection And Maintenance

Figure 151

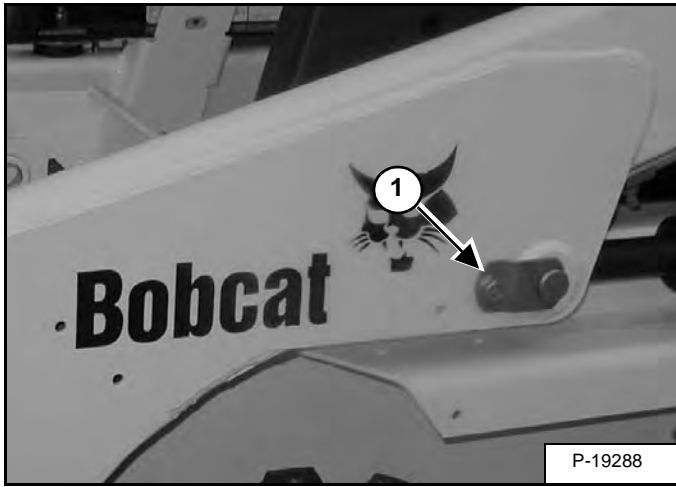
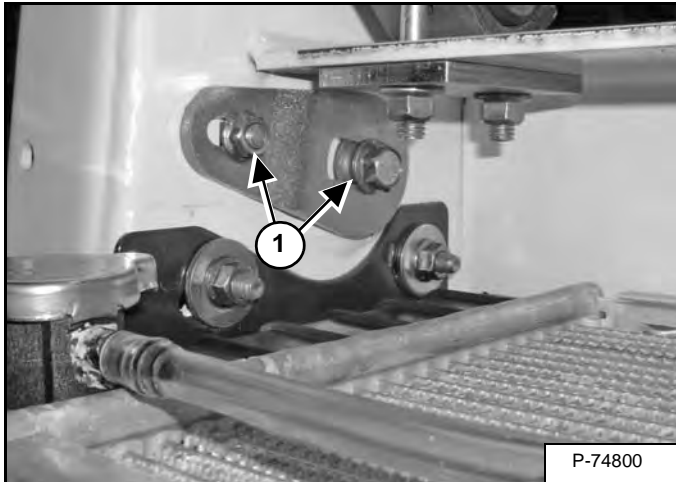

Figure 152



All lift arm and cylinder pivots have a large pin held in position with a retainer bolt and lock nut (Item 1) [Figure 151] and [Figure 152].

Tighten to 24 - 27 N•m (18 - 20 ft-lb) torque.

Do not over tighten.

Figure 153

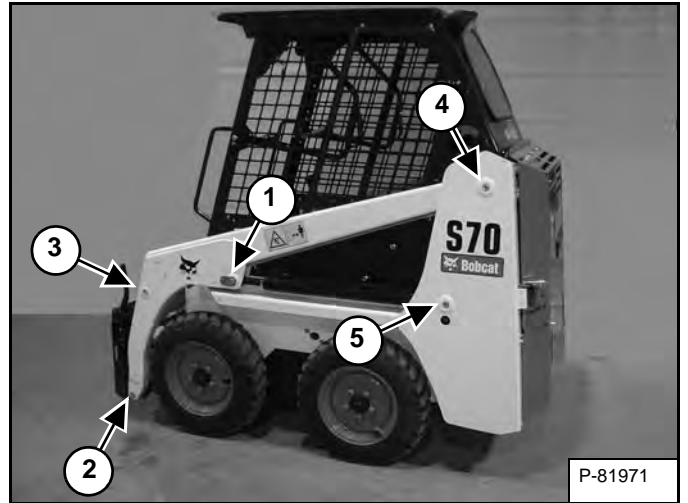
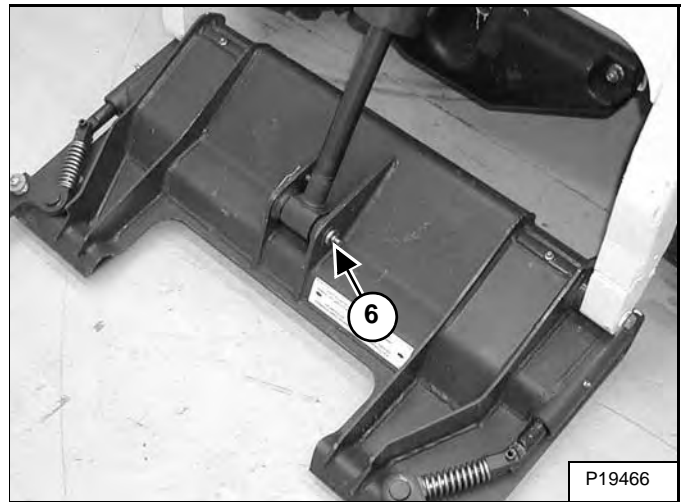

Figure 154



Check the following pivot pins (Items 1 - 6) [Figure 153] and [Figure 154].

Repeat for (Items 1 - 5) [Figure 153] on the opposite side of the loader.

# BOB-TACH

## Inspection And Maintenance

Figure 155

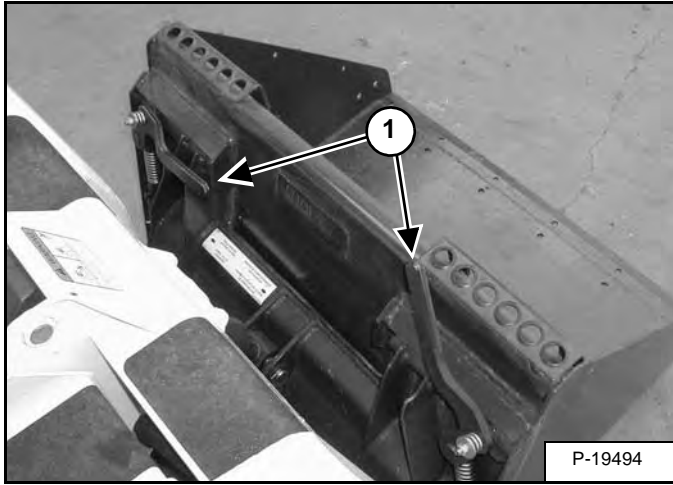

Move the Bob-Tach levers down to engage the wedges [Figure 155].

The levers and wedges must move freely.

### **WARNING**

#### **AVOID INJURY OR DEATH**

The Bob-Tach wedges must extend through the holes in the attachment mounting frame. Levers must be fully down and locked. Failure to secure wedges can allow attachment to come off.

W-2715-0208

Figure 156

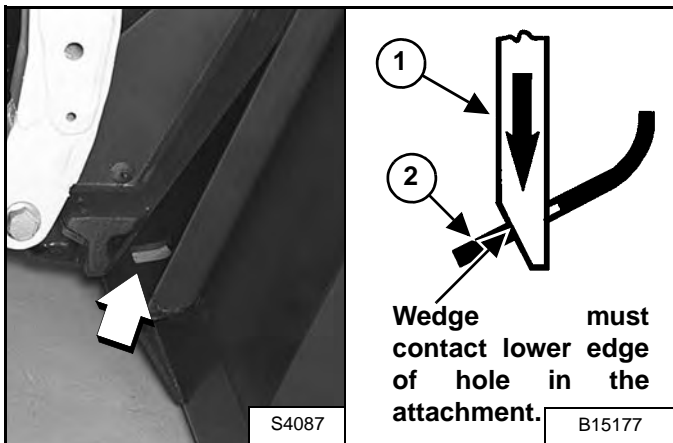

The wedges (Item 1) must extend through the holes in the attachment mounting frame (Item 2) [Figure 156].

The spring loaded wedge (Item 1) [Figure 156] must contact the lower edge of the hole in the attachment (Item 2).

If the wedge does not contact the lower edge of the hole [Figure 156], the attachment will be loose and can come off the Bob-Tach.

Figure 157

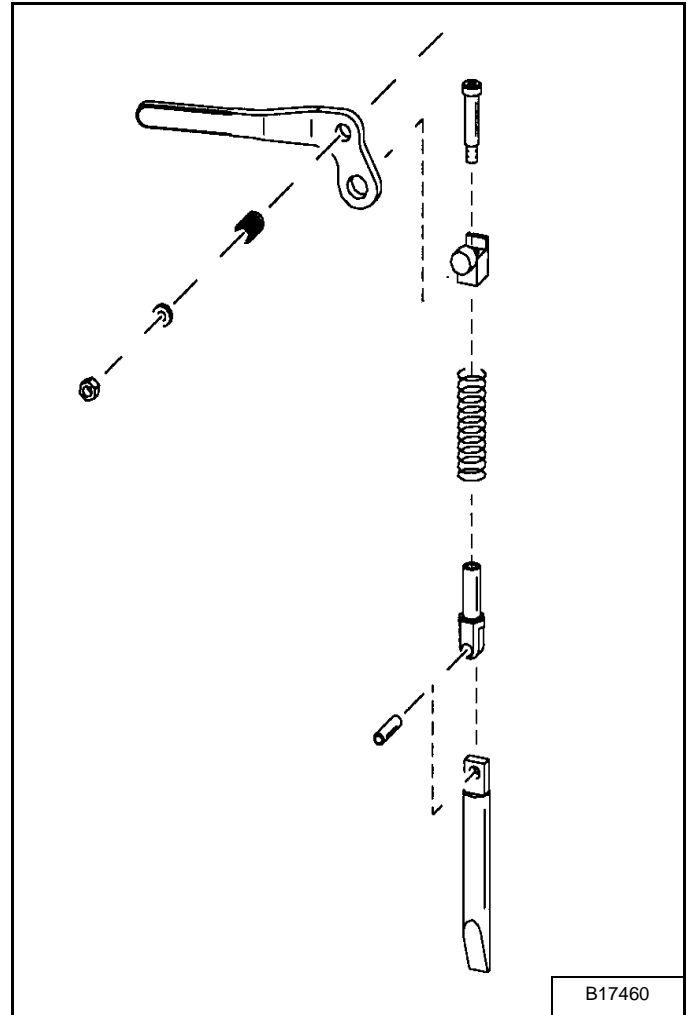

Inspect the mounting frame on the attachment and Bob-Tach, linkages and wedges for excessive wear or damage [Figure 157]. Replace any parts that are damaged, bent or missing. Keep all fasteners tight.

Look for cracked welds. Contact your Bobcat dealer for repair or replacement parts.

Lubricate the wedges. (See SERVICE SCHEDULE on Page 71.) and (See LUBRICATING THE LOADER on Page 103.)

## LOADER STORAGE AND RETURN TO SERVICE

### Storage

Sometimes it may be necessary to store your Bobcat Loader for an extend period of time. Below is a list of items to perform before storage.

- Thoroughly clean the loader including the engine compartment.
- Lubricate the loader.
- Replace worn or damaged parts.
- Park the loader in a dry protected shelter.
- Lower the lift arms all the way and put the bucket flat on the ground.
- Put blocks under the frame to remove weight from the tires.
- Put grease on any exposed cylinder rods.
- Put fuel stabilizer in the fuel tank and run the engine a few minutes to circulate the stabilizer to the pump and fuel injectors.
- Drain and flush the cooling system. Refill with premixed coolant.
- Replace all fluids and filters (engine, hyd. / hydro.).
- Replace air cleaner, heater and air conditioning filters.
- Put all controls in neutral position.
- Remove the battery. Be sure the electrolyte level is correct then charge the battery. Store it in a cool dry place above freezing temperatures and charge it periodically during storage.
- Cover the exhaust pipe opening.
- Tag the machine to indicate that it is in storage condition.

### Return To Service

After the Bobcat Loader has been in storage, it is necessary to follow a list of items to return the loader to service.

- Check the engine and hydraulic oil levels; check coolant level.
- Install a fully charged battery.
- Remove grease from exposed cylinder rods.
- Check all belt tensions.
- Be sure all shields and guards are in place.
- Lubricate the loader.
- Check tire inflation and remove blocks from under frame.
- Remove cover from exhaust pipe opening.
- Start the engine and let run for a few minutes while observing the instrument panels and systems for correct operation.
- Operate machine, check for correct function.
- Stop the engine and check for leaks. Repair as needed.



**Bobcat®**

## SYSTEM SETUP AND ANALYSIS

TROUBLESHOOTING .....	111
Troubleshooting The Engine .....	111
Troubleshooting The Hydraulic System .....	112
Troubleshooting The Hydrostatic System .....	112
BOBCAT INTERLOCK CONTROL SYSTEM (BICS™) .....	113
Troubleshooting .....	113
Viewing Diagnostic Service Codes .....	113



**Bobcat®**



## TROUBLESHOOTING

The following information identifies loader problems which can occur most often. Service procedures for correcting loader problems can be found in this manual on the pages indicated. Some procedures are marked DS (Dealer Service) and must be performed only by qualified Bobcat service personnel.



### AVOID INJURY OR DEATH

**When operating the machine:**

- **Keep the seat belt fastened snugly.**
- **The seat bar must be lowered.**
- **Keep your feet on the pedal controls or footrests and hands on the controls.**

W-2261-0909

## Troubleshooting The Engine

PROBLEM	CAUSE	CORRECTION
Engine will not turn over with starter.	Battery has low charge.	Charge battery and find cause for loss of charge.
	Cables loose or dirty.	Clean and tighten battery cables.
	Damaged starter, solenoid or wiring	Check the starting circuit.
Engine turns with starter, but is difficult to start.	Wrong starting procedure.	Use correct starting procedure.
	No fuel in tank.	Add fuel.
	Dirt or water in fuel system.	Perform maintenance as needed.
	Damaged fuel pump.	Make repairs as needed.
	Fuel filter is dirty.	Install new filter.
	Hole in fuel line.	Make repairs as needed.
	Wrong oil in engine.	See Oil Specification
	Engine has lost compression.	Recondition the engine.
	Engine has overheated.	Check cooling system.
	Poor fuel quality.	Use fresh, good quality fuel.
Engine has little power or runs rough.	Dirt, water or air in fuel system.	Clean and repair as needed.
	Engine has overheated.	Check cooling system
	Governor adjustment is wrong.	Check and make adjustment if needed.
	Dirty air cleaner filter.	Check air cleaner, replace filter as needed.
	Engine has lost compression	Recondition the engine.
Engine overheats.	Cooling system is dirty. Air flow restricted.	Clean cooling system
	Engine shrouding damaged or missing.	Repair or replace.
	Engine is overloaded.	Run at full rpm

## TROUBLESHOOTING (CONT'D)

### Troubleshooting The Hydraulic System

PROBLEM	CAUSE	CORRECTION
No hydraulic action.	No hydraulic fluid.	Check fluid level and add as needed.
	Pedals are disconnected.	Check linkage. Repair as needed.
	Relief valve is damaged.	Replace the relief valve.
	Hydraulic pump is damaged.	Check pump and replace as needed.
	Hydraulic fluid is too thick. (cold temperature)	Let engine run to warm the hydraulic fluid.
Hydraulic action is rough.	Hydraulic fluid level is low.	Check fluid level and add as needed.
Hydraulic action is slow.	Pedal is hitting floor or debris under pedal.	Check adjustment. Remove dirt.
	Cylinders leak internally.	Check condition of cylinders and repair as needed.
	Hydraulic pump is damaged.	Check pump and replace as needed.
	Control valve is damaged	Check valve and repair as needed.
	Hydraulic fluid is too thick. (cold temperature)	Let engine run to warm the hydraulic fluid.
Hydraulic cylinders leak fluid.	Damage to cylinder rods or seals.	Repair cylinders.
No hydraulic flow to the front auxiliary hydraulic couplers.	Auxiliary hydraulic interlock valve closed.	Check auxiliary hydraulic interlock valve and solenoid for proper function. Repair or replace as needed.



### Troubleshooting The Hydrostatic System

PROBLEM	CAUSE	CORRECTION
No drive on both sides.	Hydraulic fluid is low.	Check fluid level. Add as needed.
	10 Micron filter is damaged.	Replace filter.
	Damaged gear pump.	Check condition of gear pump and replace if bad.
No drive on one side.	Hydrostatic system is damaged.	Check hydrostatic system.
	Control linkage is disconnected.	Repair linkage.
Machine pulls to one side.	Wrong tire pressure.	Check all tires
	Steering linkage interference.	Check steering linkage
	Damaged hydrostatic pump / motor.	Check system.
Machine moves when levers are in neutral.	Steering linkage out of adjustment.	Adjust steering linkage.
System is overheating.	Hydraulic fluid level is low.	Check fluid level.
	Plugged filter.	Install new filter element.
	Low charge pressure.	Check bypass valve.
	Bobcat is overloaded.	Use correct size attachment and run engine at full rpm.
	Hydrostatic transmission damaged.	Check hydrostatic system.

## BOBCAT INTERLOCK CONTROL SYSTEM (BICS™)

### Troubleshooting

The following list shows the probable causes when the BICS™ lights are off or flashing and the associated service codes. (See TROUBLESHOOTING on Page 111.)

Indicator Light	Light ON	Light OFF	Effect on Operation of Loader when Light is ON
	Seat Bar <u>is</u> up.	Seat Bar is down.	Lift and tilt functions will not operate.
	Control valve <u>cannot</u> be used.	Control valve can be used.	Lift and tilt functions will not operate.
	Loader cannot be moved forward and backward.	Loader <u>can</u> be moved forward and backward.	Loader cannot be moved forward and backward.

### Viewing Diagnostic Service Codes

The Seat Bar Light (Item 1), Valve Light (Item 2) and Parking Brake Light (Item 3) will flash to indicate SERVICE CODES. These lights may flash while the engine is running or with the engine OFF and the key ON.

**NOTE: Multiple SERVICE CODES and / or abnormal symptoms can be caused by a corroded or loose ground. Check grounds and both battery connections.**

The list below contains SERVICE CODES. These codes help analyze monitored functions of your Bobcat loader. Some service procedures must be performed ONLY BY QUALIFIED BOBCAT SERVICE PERSONNEL.

Indicator Light	LED	Function	Failure
1	Seat Bar - 2 Flashes	Seat Sensor	Out of Range Low
		8 Volt Sensor Supply	Out of Range Low
1	Seat Bar - 3 Flashes	Seat Sensor	Out of Range High
		8 Volt Sensor Supply	Out of Range High
2	Valve - 2 Flashes	Hydraulic Lock Valve Solenoid	Short to Battery
2	Valve - 3 Flashes	Hydraulic Lock Valve Solenoid	Short to Ground
2	Valve - 4 Flashes	Hydraulic Lock Valve Solenoid	Open Circuit
3	Parking Brake - 1 Flash	Traction Lock Hold Solenoid	Open Circuit
3	Parking Brake - 2 Flashes	Traction Lock Hold Solenoid	Short to Battery
3	Parking Brake - 3 Flashes	Traction Lock Hold Solenoid	Short to Ground
3	Parking Brake - 4 Flashes	Traction Lock Pull Output	Open Circuit
3	Parking Brake - 5 Flashes	Traction Lock Pull Output	Error On
		Traction Pull Relay	Error On
3	Parking Brake - 6 Flashes	Traction Lock Pull Output	Error Off
		Traction Pull Relay	Error Off



**Bobcat®**

## MACHINE SIGN TRANSLATIONS

MACHINE SIGN TRANSLATIONS .....	117
Service Schedule (6734534) .....	117
Warning (6579510) .....	120
Danger (6702301) .....	121
Danger (6702302) .....	121
Danger (6717343) .....	121
Warning (6579528) .....	121
Lift Arm Support Device (6711659) .....	122
Danger (7170355) .....	122
Warning (6737189) .....	123
Warning (6804233) .....	123
Warning (6576048) .....	123
Important (6732775) .....	123
Warning (6565491) .....	124
Important (6560573) .....	124
Warning (6710358) .....	125
Warning (6702255) .....	125
Warning (6577754) .....	126



**Bobcat®**

# WARNING

## AVOID INJURY OR DEATH

- Keep door closed except for service.
- Keep engine clean of flammable material.
- Keep body, loose objects and clothing away from electrical contacts, moving parts, hot parts and exhaust.
- Do not use loader in space with explosive dusts or gases or with flammable material near exhaust.
- Never use ether or starting fluid on diesel engine with glow plugs. Use only starting aids as approved by engine manufacturer.
- Leaking fluids under pressure can enter skin and cause serious injury.
- Battery acid causes severe burns; wear goggles. If acid contacts eyes, skin, or clothing, flush with water. For contact with eyes, flush and get medical attention.
- Battery makes flammable and explosive gas. Keep arcs, sparks, flames and lighted tobacco away.
- For jump start, connect negative cable to loader engine last (never at the battery). After jump start, remove negative connection at the engine first.
- Exhaust gases can kill. Always ventilate.

## SERVICE CHECKLIST AND SCHEDULE

- EVERY 10 HRS (BEFORE STARTING THE LOADER)**
- **ENGINE OIL & FILTER** - Check level and add as needed. Do not overfill. Change oil and filter after first 50 Hrs, then refer to Operation & Maintenance Manual for proper change interval for your Model.
  - **ENGINE AIR FILTER** - Check condition indicator and/ or display. Service only when required. Do not use compressed air to clean elements.
  - **ENGINE AIR SYSTEM** - Check for leaks and damaged components.
  - **ENGINE COOLING SYSTEM** - Clean debris from grill, oil cooler and radiator. Check coolant level cold; add coolant mixture if required.
  - **FUEL FILTER** - Remove trapped water.
  - **LOADER LIFT ARMS, LIFT LINKS, CYLINDERS, BOB-TACH PIVOT & WEDGES, STEERING CYLINDERS (AWS Machines Only)** - Lubricate with multipurpose lithium based grease.
  - **SEAT BELT, SEAT BAR AND CONTROL INTERLOCKS** - Check function. Repair or replace as needed. Clean dirt and debris from moving parts.
  - **BIGS** - Check for correct function. Clean dirt and debris from moving parts. Lift and Tilt functions **MUST NOT** operate with seat bar raised.
  - **TIRES** - Check air pressure. Inflate to **MAXIMUM** pressure shown on sidewall of tire.
  - **GENERAL** - Check for loose or broken parts, damaged operator cab, instrument operation, loose wheel nuts or track sprocket nuts, oil leaks, damaged or missing safety signs (decals).
- EVERY 50 HRS**
- **HYDRAULIC FLUID, HOSES AND TUBELINES** - Check fluid level and add if required. Check for damage and for leaks. Repair or replace as needed.
  - **FINAL DRIVE TRANSMISSION (CHAINCASE, Wheel Machines Only)** - Check fluid level and add if required.
  - **HYDRAULIC & STEERING CONTROLS (PEDALS, HAND, and/ or JOYSTICK)** - Check for correct operation. Adjust as needed.
  - **WHEEL NUTS / TRACK DRIVE SPROCKETS** - Check for loose nuts and tighten as needed.
  - **TRACK TENSION (Track Machines Only)** - Check tension and adjust as needed.
- EVERY 100 HRS**
- **SPARK ARRESTOR MUFFLER** - Empty spark chamber. (If equipped.)
  - **BATTERY** - Check battery for damage, hold down clamps, cables, connections and electrolyte level. Add distilled water as needed.
  - **DRIVE LINE** - Lubricate Engine-to-Pump Coupler with multipurpose lithium based grease. (If equipped.)
- EVERY 250 HRS**
- **STEERING LEVER PIVOTS** - Lubricate with multipurpose lithium based grease. (If equipped.)
  - **FUEL FILTER** - Replace filter.
  - **KING PINS (AWS Machines Only)** - Lubricate with multipurpose lithium based grease.
  - **ENGINE / HYDRAULIC DRIVE BELT** - Check for wear or damage. Adjust or replace as needed. (If equipped.)
  - **FAN DRIVE GEARBOX** - Check fluid level and add if required. (If equipped.)
  - **OTHER DRIVE BELTS (Hydrostatic pump, water pump, alternator, and air conditioner - if equipped.)** - Check condition and tension. Adjust or replace as needed.
  - **BIGS** - Check function of Lift Arm By-Pass control.
- EVERY 500 HRS**
- **FAN / HYDRAULIC / HYDROSTATIC SYSTEM** - Replace filter. Replace reservoir breather cap.
  - **STEERING VALVE INLINE FILTER (AWS Only)** - Replace filter.
  - **HYDROSTATIC MOTOR CARRIER (Track Machines Only)** - Replace oil.
- EVERY 1000 HRS**
- **HYDRAULIC RESERVOIR** - Replace fluid.
  - **FINAL DRIVE TRANSMISSION (Chaincase on Wheel Machines Only)** - Replace fluid.
  - **TRACK ROLLER, IDLER ASSEMBLIES (Track Machines Only)** - Replace fluid (if required)
  - **DRIVE MOTOR CASE DRAIN FILTER** - Replace filter (if equipped.)
  - **WHEEL BEARING & OUTER SPLINES (AWS only)** - Repack wheel bearings, grease internal splines in hub yoke. (Dealer Service Only)

**NOTES:**

- Replace element sooner if transmission warning indicator remains on for more than 5 minutes after hydraulic fluid is at operating temperature.
- Service at first 50 Hours, then as scheduled.
- See Operation & Maintenance Manual for correct fluid specifications, filter part number and location, and appropriate service interval for your Model.

SEE OPERATION & MAINTENANCE MANUAL FOR MORE INFORMATION AND INSTRUCTIONS.

## GENERAL LUBRICATION DIAGRAMS

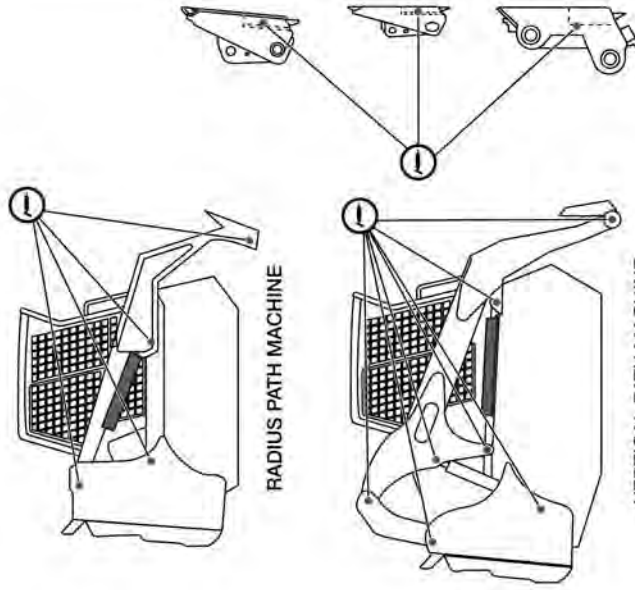

RADIUS PATH MACHINE

VERTICAL PATH MACHINE

## TYPICAL GREASE POINTS



Use Genuine Bobcat Replacement Parts

## ADVERTENCIA

### EVITE LESIONES O LA MUERTE

- Mantenga la puerta cerrada, excepto para efectuar el servicio.
- Mantenga el motor libre de materiales inflamables.
- Mantenga el cuerpo, los objetos sueltos y la ropa alejados de los contactos eléctricos; las piezas en movimiento, las piezas calientes y los escapes.
- No utilice la cargadora en espacios que contengan polvo, gases explosivos o material inflamable cerca del escape.
- Nunca utilice éter o líquido de arranque en un motor con bujías incandescentes. Utilice sólo los aditivos para el arranque aprobados por el fabricante del motor.
- Las fugas de líquido bajo presión pueden penetrar la piel y provocar lesiones graves.
- El ácido de la batería produce quemaduras graves; use anteojos protectores. Si el ácido entra en contacto con los ojos, la piel o la ropa, enjuague con agua. En caso de entrar en contacto con los ojos, enjuáguelos y solicite atención médica de inmediato.
- La batería genera gas inflamable y explosivo. Mantenga alejados los arcos, las chispas, las llamas y el tabaco encendido.
- Para realizar un puente de arranque, conecte en último lugar el cable negativo al motor de la cargadora (nunca a la batería). Después del puente de arranque, retire en primer lugar la conexión negativa del motor.
- Los gases del escape pueden ser letales. Ventíle siempre.

## LISTA DE CONTROL Y PROGRAMA DEL SERVICIO DE MANTENIMIENTO

**CADA 10 HORAS (ANTES DE ENCENDER EL CARGADOR)**

- **ACEITE Y FILTRO DEL MOTOR:** controle el nivel de aceite y agregue más cantidad si es necesario. No sobrecharge. Cambie el aceite y el filtro luego de las primeras 50 horas. Luego, consulte el Manual de funcionamiento y mantenimiento para ver la frecuencia de mantenimiento apropiada para el modelo de su máquina.
- **FILTRO DE AIRE DEL MOTOR:** controle el indicador de estado y/o la pantalla. Repare solo cuando sea necesario. Limpie o reemplace los elementos.
- **SISTEMA DE AIRE DEL MOTOR:** revise los elementos de mantenimiento y componentes dañados.
- **SISTEMA DE ENFRÍAMIENTO DEL MOTOR:** limpie y elimine la suciedad que haya en la parrilla, en el refrigerante de aceite y en el radiador. Verifique el nivel de frío del refrigerante y agregue la cantidad necesaria.
- **FILTRO DEL COMBUSTIBLE:** retire el agua que queda acumulada.
- **BRAZOS DE ELECCIÓN, CONECTORES DE ELECCIÓN, CILINDROS, PIVOTE Y CUÑAS BOB-TACH, Y CILINDROS DE DIRECCIÓN DEL CARGADOR** (sólo en máquinas con sistema AWS): lubrique con engrasador multiuso a base de litio.
- **CONTINUACIÓN DE SEGURIDAD, APOTABRIZOS Y SEGUROS DE CONTROL:** verifique si funcionan correctamente.
- **SISTEMA DE ENCLAVAMIENTO DE CONTROLES BOBCAT (BCS):** verifique si funciona correctamente. Limpie la suciedad y los desechos de las piezas en movimiento. Cuando se utilicen las funciones de elevación e inclinación, **NO SE DEBE** trabajar con la barra del asiento elevada.
- **NEUMÁTICOS:** verifique la presión del aire. Infile los neumáticos a la presión MÁXIMA, como se muestra en el lateral del neumático.
- **GENERAL:** verifique que no haya partes sueltas o rotas, que la cabina del operador no se encuentre dañada, el acondicionamiento de los instrumentos y que las tuercas de las ruedas o las tuercas del engranaje de tracción no estén flojas. Controle las fugas de aceite y la señalización de seguridad dañada o faltante (plaquetas).

**CADA 50 HORAS**

- **FLUIDO HIDRÁULICO, MANGUERAS Y TUBOS:** controle el nivel de fluido y agregue según sea necesario.
- **TRANSMISIÓN FINAL (Solo en los GUARDACADENAS de máquinas con ruedas):** controle el nivel de fluido y agregue según sea necesario.
- **CONTROLES DE DIRECCIÓN HIDRÁULICA (PEDALES, CONTROLES MANUALES y/o PALANCA DE MANDO):** verifique si funcionan correctamente.
- **TUERCA DE RUEDAS, ENGRANAJES DE TRANSMISIÓN DE LA TRACCIÓN:** verifique que las tuercas no estén sueltas y límpelas según sea necesario.
- **TENSIÓN DE LA BANDA DE TRACCIÓN (Solo en máquinas de tracción):** verifique la tensión y ajuste según sea necesario.

**CADA 100 HORAS**

- **SILENCIADOR PARA CHISPAS:** vacíe la cámara de chispas (si corresponde).
- **BATERÍA:** verifique la batería por daños, grasas de sujeciones, cables, conexiones y nivel de electrolitos. Agregue agua destilada según sea necesario.

**CADA 500 HORAS**

- **FLUIDO DE TRANSMISIÓN:** lubrique con engrasador multiuso a base de litio (si corresponde).
- **PIVOTES DE LA PALANCA DE DIRECCIÓN:** lubrique con engrasador multiuso a base de litio (si corresponde).
- **FILTRO DEL COMBUSTIBLE:** reemplácelo el filtro.
- **PIVOTES DE DIRECCIÓN (Solo en máquinas con sistema AWS):** lubrique con engrasador multiuso a base de litio.
- **MOTOR / CORREA IMPULSORA HIDRÁULICA:** controle que no estén gastados o dañados.
- Ajuste o reemplácelo según sea necesario (si corresponde).
- **CAJA DE ENGRANAJES DEL VENTILADOR:** controle el nivel de fluido y agregue según sea necesario (si corresponde).
- **OTROS CINTURONES DE SEGURIDAD (Bomba hidráulica, bomba de agua, alternador y aire acondicionado, cinturón de seguridad):** revise los cinturones de seguridad y reemplácelos según sea necesario.
- **SISTEMA DE ENCLAVAMIENTO DE CONTROLES BOBCAT (BCS):** verifique el funcionamiento del control de derivación del brazo de elevación.

**CADA 500 HORAS**

- **VENTILADOR / SISTEMA HIDRÁULICO / HIDROSTÁTICO:** reemplácelo el filtro. Reemplácelo la cubierta del respiradero del depósito.
- **FILTRO DE ENTRADA DE LA VALVULA DE DIRECCIÓN (Solo en máquinas con sistema AWS):** reemplácelo el filtro.
- **PORTADOR DEL MOTOR HIDROSTÁTICO (Solo en máquinas de tracción):** reemplácelo el aceite.

**CADA 1000 HORAS**

- **DEMANTEO HIDRÁULICO:** reemplácelo el fluido.
- **DEMANTEO FINAL:** reemplácelo el aceite.
- **RODILLO DE TRACCIÓN, CONJUNTO DE RODILLOS AUXILIARES (Solo en máquinas de tracción):** reemplácelo el fluido (si corresponde).
- **FILTRO DE DRENAJE DE LA CAJA DEL MOTOR DE TRANSMISIÓN:** reemplácelo el filtro (si corresponde).
- **COJINETES DE LAS RUEDAS Y RAMURAS EXTERIORES (Solo en máquinas con sistema AWS):** vuelva a untar grasa en los cojinetes de las ruedas y lubrique las ramuras externas en la horquilla del cubo. (Solo servicio de mantenimiento de distribuidor)

## DIAGRAMAS GENERALES DE LUBRICACIÓN

MÁQUINA DE TRAYECTORIA RADIAL

MÁQUINA DE TRAYECTORIA VERTICAL

● PUNTOS DE ENGRASE HABITUALES

73094 SW 6734534E esAF

**NOTAS:**

- Reemplácelo el elemento cuando antes si el indicador de advertencia de la transmisión permanece encendido durante más de 5 minutos luego de que el fluido hidráulico haya alcanzado la temperatura de funcionamiento.
- Realice un servicio de mantenimiento después de las primeras 50 horas y, luego, según el programa.
- Consulte el Manual de funcionamiento y mantenimiento acerca de las especificaciones de filtros, los números de piezas de filtros y las ubicaciones, así como la frecuencia apropiada para realizar el mantenimiento a su modelo de máquina.

**CONSULTE EL MANUAL DE FUNCIONAMIENTO Y MANTENIMIENTO PARA OBTENER MÁS INFORMACION E INSTRUCCIONES.**



### AVERTISSEMENT

**RISQUE DE BLESSURE OU DE MORT**

- Gardez la porte fermée sauf pour des opérations d'entretien.
- Débarrassez le moteur de tout matériau inflammable.
- Maintenez le corps, les objets mobiles et les vêtements à l'écart des contacts électriques, des pièces mobiles, des pièces brûlantes et de l'échappement.
- N'utilisez pas la chargeuse dans des lieux contenant des poussières ou des gaz explosifs ou avec des matériaux inflammables à proximité de l'échappement.
- N'utilisez jamais d'éther ou de liquide d'ade au démarrage sur les moteurs diesel équipés de bougies de préchauffage. Utilisez uniquement des aides au démarrage approuvées par le fabricant du moteur.
- En cas de fuite, le liquide sous pression peut pénétrer dans la peau et provoquer des blessures graves.
- Portez des lunettes de protection car l'acide contenu dans une batterie provoque des brûlures graves. En cas de contact d'acide sur les yeux, la peau ou les vêtements, rincez abondamment à l'eau. En cas de contact sur les yeux, rincez abondamment et consultez immédiatement un médecin.
- La batterie génère des gaz inflammables et explosifs. Maintenez-la à l'écart des arcs, des étincelles, des flammes et des cigarettes allumées.
- En cas de démarrage forcé, connectez le câble négatif au moteur de la chargeuse en dernier (jamais à la batterie). Après un démarrage forcé, retirez en premier la connexion négative au moteur.
- Les gaz d'échappement peuvent être mortels. Veillez à toujours aérer la zone.

### LISTE DE CONTRÔLE ET PÉRIODICITÉ DES ENTRETIENS

**TOUTES LES 10 H (AVANT DE DÉMARRER LA CHARGEUSE)**

- **HUILE ET FILTRE MOTEUR** - Vérifiez le niveau et faites l'appoint si nécessaire. Ne dépassez pas le niveau indiqué. Changez l'huile et le filtre après les 50 premières heures; puis consultez le manuel d'utilisation et d'entretien pour connaître la périodicité de changement d'huile pour votre modèle.
- **FILTRES À AIR DU MOTEUR** - Vérifiez l'indicateur d'état et/ou l'affichage. N'effectuez que l'entretien nécessaire. N'utilisez pas d'air comprimé pour nettoyer les éléments.
- **CIRCUIT DE VENTILATION DU MOTEUR** - Vérifiez l'étanchéité et l'état des éléments.
- **CIRCUIT DE REPRODUCTION DU MOTEUR** - Otez les débris de la grille, du refroidisseur d'huile et du radiateur. Vérifiez le niveau du liquide de refroidissement à froid; faites l'appoint au besoin.
- **FILTRE D'ALIMENTATION** - Refaites l'eau plégée.
- **DE BRAS DE LEVAGE DE LA CHARGEUSE; ARTICULATIONS DE LEVAGE, VÉRINS, PIVOT ET CALES DU BOB-TACH, VÉRINS** - Vérifiez l'étanchéité et l'état des joints de la base de lithium.
- **CEINTURE DE SÉCURITÉ ARCADE DE SIÈGE ET VERTICUR LÉVAGE DES COMMANDES** - Vérifiez l'étanchéité et l'état des pièces mobiles. Remplacez les pièces défectueuses.
- **BICS** - Vérifiez son bon fonctionnement. Éliminez les saletés et les ébréures des pièces mobiles. Les fonctions de levage et de sauvetage NE DOIVENT PAS fonctionner lorsque l'arcade de siège est relevé.
- **PNEUS** - Vérifiez la pression. Gonflez à la pression MAXIMALE indiquée sur la paroi du pneu.
- **GÉNÉRAL** - Contrôlez toute pièce détachée ou endommagée, le bon état de la cabine de l'opérateur, le fonctionnement des instruments, le serrage des écrous de roues ou des écrous de galets de chenilles, les fuites d'huile, les autocollants abîmés ou manquants.

**TOUTES LES 50 H**

- **HUILE HYDRAULIQUE, FLEXIBLES ET CONDUITES** - Vérifiez le niveau d'huile et faites l'appoint le cas échéant. Vérifiez la présence de dégat ou de fuite. Effectuez les réparations ou les remplacements requis.
- **TRANSMISSION FINALE (CARTER DE CHAÎNE, machines sur roues uniquement)** - Vérifiez le niveau ou l'état de l'huile et faites l'appoint si nécessaire.
- **COMMANDES HYDRAULIQUES ET DE DIRECTION PÉDALES, POIGNÉE et/ou MANIPULATEUR** - Vérifiez leur bon fonctionnement. Effectuez les réglages nécessaires.
- **ÉCROUS DE ROUES / BARBOTINS D'ENTRAÎNEMENT FINAL** - Vérifiez le serrage des écrous, ressermez-les si nécessaire.
- **TENSION DES CHENILLES (machines à chenilles uniquement)** - Vérifiez la tension et effectuez les réglages nécessaires.

**TOUTES LES 100 H**

- **SILÊNCIEUX PARE-ÉTINCELLES** - Videz la chambre à étincelles (le cas échéant).
- **BATTERIE** - Vérifiez l'état de la batterie, des brides de fixations, des câbles, des connexions et le niveau d'électrolyte. Ajoutez de l'eau distillée si nécessaire.
- **CHAÎNE CINÉMATIQUE** - Graissez le raccord moteur/pompe avec de la graisse multi-usages à base de lithium.

**TOUTES LES 250 H**

- **PIVOTS DES LEVIER DE DIRECTION** - Graissez avec de la graisse multi-usages à base de lithium (le cas échéant).
- **FILTRE D'ALIMENTATION** - Remplacez le filtre.
- **AXES DE FUSÉES (machines à roues directrices uniquement)** - Graissez avec de la graisse multi-usages à base de lithium.
- **COURROIE D'ENTRAÎNEMENT MOTEUR / HYDRAULIQUE** - Vérifiez que la courroie n'est ni usée ni déformée. Effectuez les réglages ou les remplacements requis (le cas échéant).
- **BOÎTE À ENGRÈNAGES DU VENTILATEUR** - Vérifiez le niveau d'huile et faites l'appoint si nécessaire (le cas échéant).
- **AUTRES COURROIES D'ENTRAÎNEMENT** (pompe hydrostatique, pompe à eau, alternateur et climatiseur - le cas échéant) - Vérifiez l'état et la tension. Effectuez les réglages ou les remplacements requis.
- **BICS** - Vérifiez le bon fonctionnement de la commande de dérivation des bras de levage.

**TOUTES LES 500 H**

- **VENTILATEUR / CIRCUIT HYDROSTATIQUE / HYDRAULIQUE** - Remplacez le filtre. Remplacez le bouchon remplissage du réservoir.
- **FILTRE INTÉGRÉ DU CLAPET DE DIRECTION (modèles à roues directrices uniquement)** - Remplacez le filtre.
- **PORTE-MOTEUR HYDROSTATIQUE (machines sur chenilles uniquement)** - Remplacez l'huile.
- **RÉSÉROIR HYDRAULIQUE** - Remplacez le fluide.
- **TRANSMISSION FINALE (carter de chaînes, machines sur roues uniquement)** - Remplacez l'huile.
- **ENSEMBLES GALETS DE CHENILLE/ROUE DE TENSION (machines sur chenilles uniquement)** - Remplacez le fluide (si nécessaire).
- **FILTRE DE RETOUR DE CARTER DU MOTEUR D'ENTRAÎNEMENT** - Remplacez le filtre (le cas échéant).
- **ROULEMENT DE ROUES ET CANNELURES MALES (modèles à roues directrices uniquement)** - Graissez à plein les roulements de roues, graissez les cannelures femelles de la fourche (entretien) par le concessionnaire uniquement.

### SCHEMAS GÉNÉRAUX DE GRAISSAGE

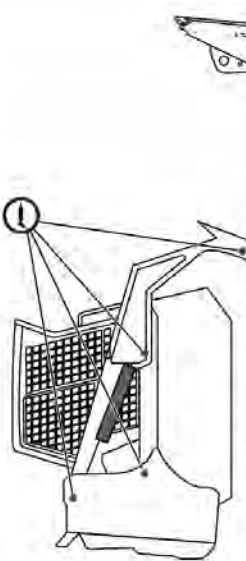

**LEVAGE EN ARC DE CERCLE**

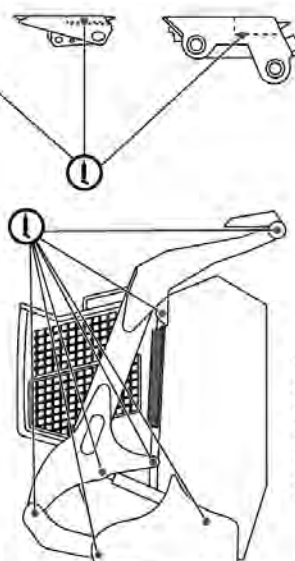

**LEVAGE VERTICAL**

■ POINTS DE GRAISSAGE TYPIQUES



**Utilisez des pièces de rechange Bobcat d'origine**

**CONSULTEZ LE MANUEL D'UTILISATION ET D'ENTRETIEN POUR DES INSTRUCTIONS ET DES INFORMATIONS SUPPLÉMENTAIRES.**

**REMARQUES :**

- remplacez l'élément plus tôt si le témoin d'avertissement de la transmission reste allumé pendant plus de 5 minutes une fois que l'huile hydraulique a atteint la température de fonctionnement.
- Effectuez l'entretien après 50 heures, puis selon le tableau.
- Consultez le manuel d'utilisation et d'entretien pour les spécifications sur les fluides, le numéro de pièce et l'emplacement du filtre, et la périodicité d'entretien appropriée pour votre modèle.

6734534E ICA  
73094 SW

<b>⚠ WARNING</b>											
<b>AVOID INJURY OR DEATH</b>											
			<b>TO LEAVE THE LOADER:</b>								
<p>NEVER USE THE LOADER WITHOUT INSTRUCTIONS. READ OPERATION AND MAINTENANCE MANUAL AND HANDBOOK.</p>	<p>USE SEAT BAR. FASTEN SEAT BELT SECURELY.</p>	<p>KEEP FEET ON PEDALS.</p>	<table border="1"> <tr> <td style="text-align: center;">1 </td> <td style="text-align: center;">2 </td> </tr> <tr> <td style="vertical-align: top;"> <p>LOWER THE LIFT ARMS. PUT ATTACHMENT FLAT ON GROUND.</p> </td> <td style="vertical-align: top;"> <p>STOP THE ENGINE.</p> </td> </tr> <tr> <td style="text-align: center;">3 </td> <td style="text-align: center;">4 </td> </tr> <tr> <td style="vertical-align: top;"> <p>ENGAGE THE BRAKE.</p> </td> <td style="vertical-align: top;"> <p>RAISE SEAT BAR. MOVE PEDALS UNTIL BOTH LOCK.</p> </td> </tr> </table>	1 	2 	<p>LOWER THE LIFT ARMS. PUT ATTACHMENT FLAT ON GROUND.</p>	<p>STOP THE ENGINE.</p>	3 	4 	<p>ENGAGE THE BRAKE.</p>	<p>RAISE SEAT BAR. MOVE PEDALS UNTIL BOTH LOCK.</p>
1 	2 										
<p>LOWER THE LIFT ARMS. PUT ATTACHMENT FLAT ON GROUND.</p>	<p>STOP THE ENGINE.</p>										
3 	4 										
<p>ENGAGE THE BRAKE.</p>	<p>RAISE SEAT BAR. MOVE PEDALS UNTIL BOTH LOCK.</p>										
<p>DO NOT TRAVEL OR TURN WITH LIFT ARMS UP. LOAD, UNLOAD AND TURN ON FLAT LEVEL GROUND. DO NOT EXCEED RATED OPERATING CAPACITY (SEE SIGN ON LOADER).</p>	<p>NEVER MODIFY EQUIPMENT OR USE ATTACHMENTS NOT APPROVED BY MELROE COMPANY.</p>	<p>ON SLOPES, KEEP HEAVY END OF LOADER UPHILL.</p>	<p>Weitere Anweisungen finden sie in der Bedienung - und Instandhaltungsanleitung. Para más instrucciones, vea el Manual de Operación y Mantenimiento. Voir le Manuel de l'opérateur et d'entretien pour d'autres renseignements. 276-40 SW02 6579510</p>								

<b>⚠ ADVERTENCIA</b>											
<b>EVITE LESIONES O LA MUERTE</b>											
			<b>ANTES DE BAJARSE DEL CARGADOR</b>								
<p>NUNCA USE EL CARGADOR SIN LEER LAS INSTRUCCIONES. LEA EL MANUAL DE OPERACIÓN Y MANTENIMIENTO Y LA GUÍA.</p>	<p>USE LA BARRA DEL ASIENTO. ABRÓCHESE BIEN EL CINTURÓN DE SEGURIDAD.</p>	<p>MANTEGA LOS PIES EN LOS PEDALES.</p>	<table border="1"> <tr> <td style="text-align: center;">1 </td> <td style="text-align: center;">2 </td> </tr> <tr> <td style="vertical-align: top;"> <p>BAJE LOS BRAZOS DE ELEVACIÓN. COLOQUE EL IMPLEMENTO PLANO EN EL SUELO.</p> </td> <td style="vertical-align: top;"> <p>APAGUE EL MOTOR.</p> </td> </tr> <tr> <td style="text-align: center;">3 </td> <td style="text-align: center;">4 </td> </tr> <tr> <td style="vertical-align: top;"> <p>COLOQUE EL FRENO.</p> </td> <td style="vertical-align: top;"> <p>LEVANTE LA BARRA DEL ASIENTO. MUEVA LOS PEDALES HASTA QUE AMBOS SE ASEGUEN</p> </td> </tr> </table>	1 	2 	<p>BAJE LOS BRAZOS DE ELEVACIÓN. COLOQUE EL IMPLEMENTO PLANO EN EL SUELO.</p>	<p>APAGUE EL MOTOR.</p>	3 	4 	<p>COLOQUE EL FRENO.</p>	<p>LEVANTE LA BARRA DEL ASIENTO. MUEVA LOS PEDALES HASTA QUE AMBOS SE ASEGUEN</p>
1 	2 										
<p>BAJE LOS BRAZOS DE ELEVACIÓN. COLOQUE EL IMPLEMENTO PLANO EN EL SUELO.</p>	<p>APAGUE EL MOTOR.</p>										
3 	4 										
<p>COLOQUE EL FRENO.</p>	<p>LEVANTE LA BARRA DEL ASIENTO. MUEVA LOS PEDALES HASTA QUE AMBOS SE ASEGUEN</p>										
<p>NO VIAJE O GIRE CON LOS BRAZOS DE ELEVACIÓN ARRIBA. CARGUE, DESCARGUE Y GIRE EN UN SITIO PLANO Y NIVELADO. NO EXCEDA LA CAPACIDAD NOMINAL OPERATIVA (VEA EL AVISO EN EL CARGADOR).</p>	<p>NUNCA MODIFIQUE EL EQUIPO NI USE IMPLEMENTOS QUE NO ESTÉN APROBADOS POR MELROE COMPANY.</p>	<p>EN LAS PENDIENTES, MANTENGA EL EXTREMO PESADO DEL CARGADOR EN POSICIÓN ASCENDENTE.</p>	<p>Para más instrucciones, consulte el Manual de operación y mantenimiento. 276-40 SW01 6579510AR</p>								

<b>⚠ ATTENTION</b>											
<b>EVITER LES BLESSURES OU LA MORT</b>											
			<b>POUR QUITTER LA CHARGEUSE:</b>								
<p>NE VOUS SERVEZ JAMAIS DE LA CHARGEUSE SANS INSTRUCTIONS. LISEZ LE MANUEL DE L'OPÉRATEUR ET D'ENTRETIEN AINSI QUE LE GUIDE D'UTILISATION.</p>	<p>UTILISEZ L'ARCEAU DE SECURITE. ATTACHEZ SOIGNEUSEMENT LA CEINTURE DE SECURITE</p>	<p>MAINTENEZ LES PIEDS SUR LES PEDALES</p>	<table border="1"> <tr> <td style="text-align: center;">1 </td> <td style="text-align: center;">2 </td> </tr> <tr> <td style="vertical-align: top;"> <p>ABAISSÉZ LES BRAS DE LEVAGE POSEZ L'EQUIPEMENT A PLAT SUR LE SOL.</p> </td> <td style="vertical-align: top;"> <p>ARRÊTEZ LE MOTEUR.</p> </td> </tr> <tr> <td style="text-align: center;">3 </td> <td style="text-align: center;">4 </td> </tr> <tr> <td style="vertical-align: top;"> <p>ENCLÉNCHEZ LE FREIN DE STATIONNEMENT</p> </td> <td style="vertical-align: top;"> <p>RELEVEZ L'ARCEAU DE SIEGE. DEPLACEZ LES PEDALES JUSQU'A CE QU'ELLES SOIENT TOUTES DEUX VERROUILLEES.</p> </td> </tr> </table>	1 	2 	<p>ABAISSÉZ LES BRAS DE LEVAGE POSEZ L'EQUIPEMENT A PLAT SUR LE SOL.</p>	<p>ARRÊTEZ LE MOTEUR.</p>	3 	4 	<p>ENCLÉNCHEZ LE FREIN DE STATIONNEMENT</p>	<p>RELEVEZ L'ARCEAU DE SIEGE. DEPLACEZ LES PEDALES JUSQU'A CE QU'ELLES SOIENT TOUTES DEUX VERROUILLEES.</p>
1 	2 										
<p>ABAISSÉZ LES BRAS DE LEVAGE POSEZ L'EQUIPEMENT A PLAT SUR LE SOL.</p>	<p>ARRÊTEZ LE MOTEUR.</p>										
3 	4 										
<p>ENCLÉNCHEZ LE FREIN DE STATIONNEMENT</p>	<p>RELEVEZ L'ARCEAU DE SIEGE. DEPLACEZ LES PEDALES JUSQU'A CE QU'ELLES SOIENT TOUTES DEUX VERROUILLEES.</p>										
<p>NE PAS SE DEPLACER NI VIRER AVEC LES BRAS RELEVÉS. CHARGEZ, DÉCHARGEZ ET VIREZ SUR UN SOL PLAT ET HORIZONTAL. NE DÉPASSEZ PAS LA CAPACITÉ OPERATIONNELLE</p>	<p>NE JAMAIS MODIFIER L'EQUIPEMENT NI SE SERVIR D'ACCESSOIRES QUI NE SONT PAS APPROUVES PAR BOBCAT.</p>	<p>DANS LES PENTES, MAINTENEZ TOUJOURS LA PARTIE LA PLUS LOURDE DE LA CHARGEUSE VERS LE HAUT.</p>	<p>Weitere Anweisungen finden sie in der Bedienung - und Instandhaltungsanleitung. Para más instrucciones, vea el Manual de Operación y Mantenimiento. Voir le Manuel de l'opérateur et d'entretien pour d'autres renseignements. 276-40 VM-00-6579510-FR</p>								

MACHINE SIGN TRANSLATIONS (CONT'D)

Danger (6702301)



**⚠ DANGER**

**AVOID DEATH**

- Attachment can be forced against the ground and cause front wheels to raise.
- Never go under or reach under lift arms or lift cylinder without an approved lift arm support device installed.

67116 SW 6702301D enUS



**⚠ PELIGRO**

**EVITE ACCIDENTES FATALES**

- El implemento puede ser forzado contra el suelo y causar la elevación de los neumáticos delanteros.
- Jamás pase ni se estire por debajo de los brazos de elevación o del cilindro de elevación sin un dispositivo de soporte aprobado instalado.

67116 SW 6702301D enUS



**⚠ DANGER**

**EVITER LA MORT**

- L'accessoire peut être appuyé contre le sol et soulever les roues avant.
- Ne jamais aller sous ni mettre les mains sous les bras ou le vérin de levage sans qu'un arrêt de bras de levage approuvé soit installé.

67116 SW 6702301D enUS

Danger (6702302)

**⚠ DANGER**

**AVOID DEATH**

- Keep out of this area when lift arms are raised unless supported by an approved lift arm support device.
- Moving lift arm control or failure of a part can cause lift arms to drop.



62554 SW 6702302F enUS

**⚠ PELIGRO**

**EVITE MUERTES**

- Manténgase alejado del área cuando los brazos de elevación estén elevados, a menos que cuenten con un dispositivo de sostén aprobado.
- Si se mueve el control de los brazos de elevación o si falla alguna de las piezas, es posible que éstos se caigan.



62554 SW 6702302F enAR

**⚠ DANGER**

**RISQUE MORTEL**

- Restez à l'écart de cette zone lorsque les bras de levage sont relevés sauf s'ils sont soutenus par un arrêtoir approuvé.
- Le déplacement d'une commande de bras de levage ou la défaillance d'une pièce peut provoquer la chute des bras de levage.



62554 SW 6702302F HCA

Danger (6717343)

**⚠ DANGER**

**AVOID DEATH**

- Disconnecting or loosening any hydraulic tubeline, hose, fitting, component or a part failure can cause lift arms to drop.
- Keep out of this area when lift arms are raised unless supported by an approved lift arm support. Replace if damaged.



67116 SW 6717343A enUS

**⚠ PELIGRO**

**EVITE MUERTES**

- Si se desconecta o afloja algún tubo, manguera, accesorio o componente hidráulico, o si falla alguna de las piezas, es posible que los brazos de elevación se caigan.
- Manténgase alejado del área cuando los brazos de elevación estén elevados, a menos que cuenten con un dispositivo de sostén aprobado. Si se encuentran dañados, cámbielos.



67116 SW 6717343A enAR

**⚠ DANGER**

**RISQUE MORTEL**

- Le débranchement ou le desserrage de conduites, raccords, tuyaux ou composants hydrauliques ou une pièce hydraulique défaillante peuvent entraîner une chute des bras de levage.
- Restez éloigné de la zone où les bras de levage sont relevés, sauf s'ils sont maintenus par un arrêtoir de bras de levage approuvé. Remplacez-le en cas de dommages.



67116 SW 6717343A HCA

Warning (6579528)

**⚠ WARNING**

**AVOID INJURY OR DEATH**

**CARRY LOAD LOW**

FAILURE TO OBEY CAN CAUSE TIPPING OR ROLLOVER OR LOSS OF LOAD OR VISIBILITY.



62762 SW 6579528C enUS

**⚠ ADVERTENCIA**

**EVITE LESIONES O LA MUERTE**

**LLEVE LA CARGA BAJA**

EL INCUMPLIMIENTO PUEDE PROVOCAR TRASTORNOS, VUELCOS, PERDIDA DE LA CARGA O DE LA VISIBILIDAD.



62762 SW 6579528C enAR

**⚠ AVERTISSEMENT**

**RISQUE DE BLESSURE OU DE MORT**

**GARDEZ LA CHARGE PRÈS DU SOL**

LE NON RESPECT PEUT ENTRAÎNER UN BASCULEMENT, UN TONNEAU OU UNE PERTE DE VISIBILITÉ OU DE LA CHARGE.



62762 SW 6579528C HCA



MACHINE SIGN TRANSLATIONS (CONT'D)

Warning (6737189)

**WARNING**

THIS VEHICLE IS EQUIPPED WITH A BACK-UP ALARM.

**ALARM MUST SOUND!**

WHEN OPERATING THIS VEHICLE IN REVERSE.

FAILURE TO MAINTAIN A CLEAR VIEW IN THE DIRECTION OF TRAVEL COULD RESULT IN SERIOUS INJURY OR DEATH.

THE OPERATOR IS RESPONSIBLE FOR THE SAFE OPERATION OF THIS VEHICLE.

71848 SW 6737189B enUS

**ADVERTENCIA**

ESTE VEHÍCULO ESTÁ EQUIPADO CON UNA ALARMA DE ALERTA DE RETROCESO

**¡LA ALARMA DEBE SONAR!**

CUANDO RETROCEDA ESTE VEHÍCULO.

NO MANTENER UNA VISTA CLARA EN LA DIRECCIÓN DONDE VIAJA PUEDE RESULTAR EN LESIONES GRAVES O FATALIDADES.

EL OPERADOR ES RESPONSABLE DE LA OPERACIÓN SEGURA DE ESTE VEHÍCULO.

71848 SW 6737189B ar

**ADVERTISSEMENT**

CE VÉHICULE EST ÉQUIPÉ D'UNE ALARME DE RECVL.

**L'ALARME DOIT FONCTIONNER !**

LORSQUE VOUS UTILISEZ CE VÉHICULE EN MARCHE ARRIÈRE.

NE PAS AVOIR UNE VUE DÉGAGÉE DANS LE SENS DE LA MARCHÉ PEUT ENTRAÎNER DES BLESSURES GRAVES, VOIRE MORTELLES.

L'OPÉRATEUR EST RESPONSABLE DE LA SÉCURITÉ LORS DE L'UTILISATION DE CE VÉHICULE.

71848 SW 6737189B fr

Warning (6804233)

**WARNING**

- Hot pressurized fluid.
- Can cause serious burns.

39894 SW 6804233

**ADVERTENCIA**

- Fluido presurizado caliente.
- Puede provocar quemaduras graves.

39894 SW 6804233 AR

**AVERTISSEMENT**

- Fluide chaud sous pression.
- Peut gravement brûler.

39894 SW 6804233 frCA

Warning (6576048)



**WARNING**

KEEP FINGERS AND OBJECTS AWAY FROM FAN.

4394 SW 02 6576048



**ADVERTENCIA**

EVITE LESIONES

MANTENGA LOS DEDOS Y OBJETOS ALEJADOS DEL VENTILADOR.

4394 SW 02 6576048 AR



**AVERTISSEMENT**

GARDEZ LES DOIGTS ET LES OBJETS À DISTANCE DU VENTILATEUR.

4394 SW 02 6576048 frCA

Important (6732775)

**IMPORTANT**

Disconnect heater hose quick couplers before raising operator cab.

56941 SW 02 6732775

**IMPORTANTE**

Desconecte los acopladores rápidos de la manguera del calefactor antes de elevar la cabina del operador.

56941 SW 6732775 esAR

**IMPORTANT**

Déconnectez les coupleurs rapides du tuyau du chauffage avant de relever la cabine de l'opérateur.

56941 SW 6732775 frCA

## MACHINE SIGN TRANSLATIONS (CONT'D)

### Warning (6565491)

 **WARNING**

**AVOID INJURY OR DEATH**

Before lifting loader, check the hardware and fasteners of the single point lift and the operator's cab (ROPS).

Operator cab (ROPS) fasteners must be assembled as shown. See Operation & Maintenance Manual for assembly of the single point lift.

Never allow riders in operator cab (ROPS) during lifting of loader.

Keep 15 feet (5 meters) away from loader while lifting.

23619 SW 6565491

 **ADVERTENCIA**

**EVITE LESIONES O LA MUERTE**

Antes de levantar la cargadora, verifique los herrajes y sujetadores del punto único de elevación y la cabina del operador (ROPS, Estructura protectora de vuelcos).

Los sujetadores de la cabina del operador (ROPS) se deben montar según se indica aquí. Consulte el Manual de funcionamiento y mantenimiento para obtener instrucciones acerca del montaje del punto único de elevación.

No permita que los ocupantes ingresen a la cabina del operador (ROPS) durante la elevación de la cargadora.

Manténgase a 15 pies (5 metros) de distancia de la cargadora durante la elevación.

23619 SW 6565491

 **AVERTISSEMENT**

**RISQUE DE BLESSURE OU DE MORT**

Avant de soulever la chargeuse, vérifiez la visserie de fixation et les fixations de l'ensemble de levage à point unique et la cabine de l'opérateur (ROPS).

Les fixations de la cabine de l'opérateur (ROPS) doivent être montées comme il est illustré. Consultez le manuel d'utilisation et d'entretien pour le montage de l'ensemble de levage à point unique.

Personne ne doit se trouver dans la cabine (ROPS) lors du levage de la chargeuse.

Toutes les personnes doivent rester à au moins 5 mètres (15 pi) de la chargeuse pendant le levage.

23619 SW 6565491 frCA

### Important (6560573)

**IMPORTANT**

THIS MACHINE IS FACTORY EQUIPPED WITH A U.S.D.A. FORESTRY SERVICE APPROVED SPARK ARRESTOR EXHAUST SYSTEM.

THE SPARK ARRESTOR MUFFLER, IF EQUIPPED, MUST BE CLEANED TO KEEP IT IN WORKING CONDITION. THE SPARK ARRESTOR MUFFLER MUST BE SERVICED BY DUMPING THE SPARK CHAMBER EVERY 100 HRS OF OPERATION.

ON SOME MODELS, THE TURBOCHARGER FUNCTIONS AS THE SPARK ARRESTOR AND MUST OPERATE CORRECTLY FOR PROPER SPARK ARRESTOR FUNCTION.

IF THIS MACHINE IS OPERATED ON FLAMMABLE FOREST, BRUSH, OR GRASS COVERED LAND, IT MUST BE EQUIPPED WITH A SPARK ARRESTOR ATTACHED TO THE EXHAUST SYSTEM AND MAINTAINED IN WORKING ORDER. FAILURE TO DO SO WILL BE IN VIOLATION OF CALIFORNIA STATE LAW, SECTION 4442, PRC. REFER TO LOCAL LAWS AND REGULATIONS FOR SPARK ARRESTOR REQUIREMENTS.

SEE THE OPERATION AND MAINTENANCE MANUAL FOR MORE INSTRUCTIONS.

62554 SW 6560573G enUS

**IMPORTANTE**

ESTA MÁQUINA ESTÁ EQUIPADA DE FÁBRICA CON UN SILENCIADOR DEL SISTEMA PARACHISPAS APROBADO POR EL SERVICIO DE SILVICULTURA DE LA U.S.D.A.

EL SILENCIADOR DEL SISTEMA PARACHISPAS, SI ESTÁ EQUIPADO, DEBE LIMPIARSE PARA MANTENERSE EN CONDICIONES DE TRABAJO. ASÍ MISMO, SE LE DEBE DAR SERVICIO VACIANDO LA CÁMARA DE CHISPAS CADA 100 HORAS DE OPERACIÓN.

EN ALGUNOS MODELOS, EL TURBOCARGADOR FUNCIONA COMO EL PARACHISPAS Y DEBE OPERAR CORRECTAMENTE COMO TAL.

SI VA A OPERAR ESTA MÁQUINA EN BOSQUES INFLAMABLES O EN TERRENOS CUBIERTOS DE RAMAS O CÉSPED, DEBE DISPONER DE UN SISTEMA PARACHISPAS EN EL SISTEMA DE ESCAPE Y MANTENERLO EN BUENAS CONDICIONES DE TRABAJO. NO CUMPLIR ESTA ADVERTENCIA INFRINGIRÁ LA SECCIÓN 442 DE LA LEY DEL ESTADO DE CALIFORNIA. CONSULTE LAS LEYES Y REGLAMENTOS LOCALES ACERCA DE LOS REQUERIMIENTOS PARA UTILIZAR SISTEMAS PARACHISPAS.

PARA MAYORES INSTRUCCIONES, CONSULTE EL MANUAL DE OPERACIÓN Y MANTENIMIENTO.

62554 SW 6560573G enUS

**IMPORTANT**

CETTE MACHINE EST ÉQUIPÉE EN USINE D'UN SYSTÈME D'ÉCHAPPEMENT PARE-ÉTINCELLES APPROUVÉ PAR LE SERVICE AMÉRICAIN DES EAUX ET FORÊTS (U.S.D.A. FORESTRY SERVICE).

LE CAS ÉCHÉANT, LE SILENCIEUX PARE-ÉTINCELLES DOIT ÊTRE ENTRETENU POUR ASSURER SON BON FONCTIONNEMENT. CET ENTRETIEN CONSISTE À REMPLACER LA CHAMBRE À ÉTINCELLES TOUTES LES 100 HEURES D'EXPLOITATION.

SUR CERTAINS MODÈLES, LA FONCTION DE PARE-ÉTINCELLES EST ASSURÉE PAR LE TURBOCOMPRESSEUR QUI DOIT FONCTIONNER CORRECTEMENT POUR REMPLIR SA FONCTION.

SI VOUS UTILISEZ LA MACHINE EN FORÊT, SUR TERRAIN HERBEUX OU DANS DES TAILLIS, VOUS DEVEZ ÉQUIPER LE SYSTÈME D'ÉCHAPPEMENT D'UN PARE-ÉTINCELLES ET LE GARDER EN BON ÉTAT DE FONCTIONNEMENT. LE NON RESPECT DE CETTE OBLIGATION CONTREVIENT À LA LOI DE L'ÉTAT DE CALIFORNIE, SECTION 4442 PRC. VEUILLEZ VOUS RÉFÉRER AUX LOIS ET RÉGLEMENTS LOCAUX POUR CONNAÎTRE LES EXIGENCES EN MATIÈRE DE PARE-ÉTINCELLES.

VEUILLEZ CONSULTER LE MANUEL DE L'OPÉRATEUR ET D'ENTRETIEN POUR DES INSTRUCTIONS COMPLÉMENTAIRES.

62554 SW 6560573G enUS

MACHINE SIGN TRANSLATIONS (CONT'D)

Warning (6710358)

**⚠ WARNING**



**AVOID INJURY OR DEATH**

- Never carry riders.
- Never use loader as a man lift or work platform.

62702 SW 6710358B enUS

**⚠ ADVERTENCIA**



**EVITE LESIONES O LA MUERTE**

- Nunca lleve ocupantes.
- Nunca utilice la cargadora para levantar personas o como plataforma de trabajo.

62702 SW 6710358B esAR

**⚠ AVERTISSEMENT**



**RISQUE DE BLESSURE OU DE MORT**

- Ne transportez jamais de passagers.
- N'utilisez jamais la chargeuse comme élévateur pour le personnel ou comme plateforme de travail.

62702 SW 6710358B frCA

Warning (6702255)

**⚠ WARNING**



**AVOID INJURY OR DEATH**

SEE OPERATION & MAINTENANCE OR SERVICE MANUAL FOR INSTRUCTIONS TO:

- BLOCK UP LOADER
- LIFT AND LOWER THE CAB

6702255

**⚠ ADVERTENCIA**



**EVITE LESIONES O LA MUERTE**

CONSULTE EL MANUAL DE OPERACIÓN Y MANTENIMIENTO O DE SERVICIO PARA OBTENER MÁS INSTRUCCIONES SOBRE CÓMO:

- BLOQUEAR EL CARGADOR.
- SUBIR Y BAJAR LA CABINA.

27966 SW 00 6702255 AR

**⚠ ATTENTION**



**EVITER LES BLESSURES OU LA MORT**

VOIR LE MANUEL DE L'OPERATEUR OU LE MANUEL D'ATELIER CONCERNANT:

- LE BLOCAGE DE LA CHARGEUSE.
- LE LEVAGE ET L'ABAISSEMENT DE LA CABINE.

27966 VM-00-6702255-FR

MACHINE SIGN TRANSLATIONS (CONT'D)

Warning (6577754)



# WARNING

CYLINDER CONTAINS HIGH PRESSURE GAS. DO NOT OPEN. OPENING CYLINDER  
CAN RELEASE ROD AND CAUSE INJURY OR DEATH. 6577754



# ADVERTENCIA

EL CILINDRO CONTIENE GAS DE ALTA PRESIÓN. NO LO ABRA. SI SE ABRE EL CILINDRO, SE  
PUEDE LIBERAR EL VÁSTAGO Y SE PUEDEN OCASIONAR LESIONES O LA MUERTE.

29779

SW 6577754 AR



# AVERTISSEMENT

LES VERINS RENFERMENT UN GAZ SOUS PRESSION. N'OUVREZ JAMAIS UN VERIN, SOUS PEINE DE VOIR S'ÉCHAPPER  
BRUTALEMENT LA TIGE, CAUSANT AINSI DES BLESSURES GRAVES, VOIRE MORTELLES.

DV-99-6577754-FR



## SPECIFICATIONS

(S70) LOADER SPECIFICATIONS .....	129
Machine Dimensions .....	129
Performance .....	130
Engine .....	130
Drive System .....	130
Controls .....	131
Hydraulic System .....	131
Electrical .....	132
Capacities .....	132
Tires .....	132



**Bobcat®**



## (S70) LOADER SPECIFICATIONS (CONT'D)

### Performance

Rated Operating Capacity	318 kg (700 lb)
Tipping Load	686 kg (1512 lb)
Operating Weight	1268 kg (2795 lb)
SAE Breakout Force - Lift - Tilt	8607 N (1935 lb) 8674 N (1950 lb)
Travel Speed	0 - 9,8 km/h (0 - 6.1 mph)
Push Force	9519 N (2140 lb)

### Engine

Make / Model: - A3W611001 & Above - A3W711001 & Above - B38V11001 & Above	Kubota / D1005-E3B-BC-3 Tier 4 Kubota / D1005-E3B-BC-3 Tier 4 Kubota / D1005-E4B-BC-3 Tier 4 NRTC
Fuel / Cooling	Diesel / Liquid
Horsepower: - ISO 9249 / SAE J1349 Net - ISO 14396 - SAE J1995 Gross	16,8 kW (22.5 hp) @ 3000 rpm 17,2 kW (23.1 hp) @ 3000 rpm 17,5 kW (23.5 hp) @ 3000 rpm
Torque (SAE J1349 Gross)	62,8 N•m (45.6 ft-lb) @ 2200 rpm
Number of Cylinders	Three
Displacement	1001,0 cm <sup>3</sup> (61.08 in <sup>3</sup> )
Bore / Stroke	76,0 mm / 73,6 mm (2.99 in / 2.90 in)
Lubrication	Gear Pump Pressure System with Filter
Crankcase Ventilation	Closed Breathing
Air Cleaner	Dry replaceable paper cartridge with separate safety element
Ignition	Diesel Compression
Air Induction	Naturally Aspirated
Low Idle	1125 - 1175 rpm
High Idle	3125 - 3175 rpm
Engine Coolant	Propylene Glycol / Water Mixture

### Drive System

Main Drive	Hydrostatic 4 wheel drive
Transmission	Infinitely variable tandem hydrostatic piston pumps, driving two fully reversing hydrostatic motors.
Final Drive	Pre-stressed #60 HS endless roller chain (no master link) and sprockets in sealed chaincase with oil lubrication (Chains do not require periodic adjustments) Two chains per side with no idler sprocket
Total Engine to Wheel Reduction	31.25:1
Axle Size	37,6 mm (1.50 in), Heat treated
Wheel Bolts	Five - 9/16 in. Wheel bolts fixed to axle hubs

## (S70) LOADER SPECIFICATIONS (CONT'D)

### Controls

Vehicle Steering	Direction and speed controlled by two hand operated steering levers.
Loader Hydraulics - Lift and Tilt	Controlled by separate foot pedals.
- Front Auxiliary Hydraulics (Std.)	Controlled by lateral movement of the right hand steering lever.
Engine	Hand lever speed control, key type start switch or optional keyless start, and optional engine shutdown (Rental Kit).
Starting Aid	Glow Plug - Automatically activated by Key Switch or Keyless instrumentation.
Service Brake	Two independent hydrostatic systems controlled by two hand operated steering levers.
Secondary Brake	One of the hydrostatic transmissions.
Parking Brake (Standard)	Mechanical disc, manually operated switch on front instrument panel.

### Hydraulic System

Pump Type	Engine driven gear type
Pump Capacity	33,7 L/min (8.9 U.S. gpm) @ 3150 engine rpm
Filters	Full flow replaceable, 10 micron synthetic media element
System Relief at Quick Couplers	20,7 MPa (207 bar) (3000 psi)
Hydraulic Cylinders Bore Diameter: Lift Cylinder (2) Tilt Cylinder (1) Rod Diameter: Lift Cylinder (2) Tilt Cylinder (1) Stroke: Lift Cylinder (2) Tilt Cylinder (1)	Double acting; Tilt cylinder has cushioning feature on dump and rollback 50,8 mm (2.00 in) 76,2 mm (3.00 in) 31,8 mm (1.25 in) 31,8 mm (1.25 in) 555,5 mm (21.87 in) 268,2 mm (10.56 in)
Control Valve	3-Spool, open center type with spring detent for lift float and detent auxiliary hydraulic spool
Fluid Lines	SAE standard tubelines, hoses and fittings.
Fluid Type	BOBCAT FLUID, Hydraulic / Hydrostatic 6903117 - (2.5 U.S. gal) 6903118 - (5 U.S. gal) 6903119 - (55 U.S. gal)
Hydraulic Function Time: Raise Lift Arms Lower Lift Arms Bucket Dump Bucket Rollback	3.6 Seconds 2.7 Seconds 2.1 Seconds 1.7 Seconds

## (S70) LOADER SPECIFICATIONS (CONT'D)

### Electrical

Alternator	Belt driven, 65 amperes ventilated
Battery	12 volt, 600 cold cranking amperes @ -18°C (0°F) 115 minute reserve capacity at 25 amperes
Starter	12 volt, gear type, 2,7 kW (3.62 hp)
Instrumentation	<b>Gauges:</b> Hourmeter, Engine Coolant Temperature, Voltmeter, and Fuel Level (on tank). <b>Warning lights:</b> Engine Warning, Transmission Warning, and Seat Belt. <b>Indicators:</b> BICS™ Functions.

### Capacities

Engine Cooling System	5,7 L (6.0 qt)
Fuel	24,6 L (6.5 U.S. gal)
Engine Lubrication with Filter	3,7 L (3.9 qt)
Hydraulic / Hydrostatic Reservoir	5 L (5.3 qt)
Hydraulic / Hydrostatic System	15,1 L (4.0 U.S. gal)
Chaincase Reservoir	11,4 L (3.0 U.S. gal)

### Tires

Standard Duty (Standard)	23 x 5.70 - 12, 4 Ply Rating
Heavy Duty (Option)	23 x 8.50 - 12, 6 Ply Rating
Recommended Pressure	Inflate tires to MAXIMUM pressure shown on the side wall of the tire. DO NOT mix brands of tires used on the same loader.

**WARRANTY**

WARRANTY .....135



**Bobcat®**



# WARRANTY

## Bobcat Loaders

Bobcat Company warrants to its authorized dealers and authorized dealers of Bobcat Equipment Ltd., who in turn warrant to the owner, that each new Bobcat loader will be free from proven defects in material and workmanship with respect to (i) all components of the product except as otherwise specified herein for twelve (12) months, (ii) the drive belt from the hydrostatic pump to the engine, for thirty six (36) months, provided that after the initial twelve month warranty period, such warranty shall be limited to parts only and does not include labor, (iii) tracks and Bobcat brand tires, for twelve (12) months on a prorated basis based on the remaining depth of the track or tire at the time any defect is discovered, and (iv) Bobcat brand batteries, for an additional twelve (12) months after the initial twelve month warranty period, provided that Bobcat Company shall only reimburse a fixed portion of the cost of replacing the battery during such additional twelve months. The foregoing time periods shall all commence after delivery by the authorized Bobcat dealer to the original buyer.

During the warranty period, the authorized Bobcat dealer shall repair or replace, at Bobcat Company's option, without charge for parts and labor, any part of the Bobcat product except as otherwise specified herein which fails because of defects in material or workmanship. The owner shall provide the authorized Bobcat dealer with prompt written notice of the defect and allow reasonable time for repair or replacement. Bobcat Company may, at its option, require failed parts to be returned to the factory. Travel time of mechanics and transportation of the Bobcat product to the authorized Bobcat dealer for warranty work are the responsibility of the owner. The remedies provided in this warranty are exclusive.

This warranty does not apply to diesel engine fuel injection pumps and injectors or tires (except Bobcat brand tires). The owner shall rely solely on the warranty, if any, of the respective manufacturers thereof. This warranty does not cover replacement of scheduled service items such as oil, filters, tune-up parts, and other high-wear items. This warranty does not cover damages resulting from abuse, accidents, alterations, use of the Bobcat product with any accessory or attachment not approved by Bobcat Company, air flow obstructions, or failure to maintain or use the Bobcat product according to the instructions applicable to it.

**THIS WARRANTY IS EXCLUSIVE AND IN LIEU OF ALL OTHER WARRANTIES AND CONDITIONS, EXCEPT THE WARRANTY OF TITLE. BOBCAT COMPANY DISCLAIMS ALL OTHER WARRANTIES AND CONDITIONS, EXPRESS OR IMPLIED, INCLUDING ANY IMPLIED WARRANTIES OR CONDITIONS OF MERCHANTABILITY OR FITNESS FOR A PARTICULAR PURPOSE. IN NO EVENT SHALL BOBCAT COMPANY OR THE AUTHORIZED BOBCAT DEALER BE LIABLE FOR ANY SPECIAL, INCIDENTAL, INDIRECT OR CONSEQUENTIAL DAMAGES WHATSOEVER, INCLUDING, BUT NOT LIMITED TO, LOSS OR INTERRUPTION OF BUSINESS, LOST PROFITS, OR LOSS OF MACHINE USE, WHETHER BASED ON CONTRACT, WARRANTY, TORT, NEGLIGENCE, STRICT LIABILITY, STATUTE OR OTHERWISE, EVEN IF BOBCAT COMPANY OR THE AUTHORIZED BOBCAT DEALER HAS BEEN ADVISED OF THE POSSIBILITY OF SUCH DAMAGES. THE TOTAL LIABILITY OF BOBCAT COMPANY AND THE AUTHORIZED BOBCAT DEALERS WITH RESPECT TO THE PRODUCT AND SERVICES FURNISHED HEREUNDER SHALL NOT EXCEED THE PURCHASE PRICE OF THE PRODUCT UPON WHICH SUCH LIABILITY IS BASED.**



## WARRANTY (CONT'D)

In this emissions limited warranty, the term "Manufacturer" means Kubota Corporation as the holder of the U.S. Environmental Protection Agency (U.S. EPA) Certificate of Conformity and California Executive Order for the vehicle. The emission control limited warranty is in addition to the standard limited warranty for your vehicle.

Your Bobcat dealer is authorized to perform all warranty and service repairs on your diesel engine. To locate a Bobcat dealer, visit [www.bobcat.com](http://www.bobcat.com) or call 1-800-743-4340.

# KUBOTA Corporation

## FEDERAL & CALIFORNIA EMISSION CONTROL SYSTEMS LIMITED WARRANTY for NON-ROAD ENGINES (CI)

The U.S. Environmental Protection Agency (EPA), the California Air Resources Board (CARB), and KUBOTA Corporation are pleased to explain the Federal and California Emission Control System Warranty on your non-road engine. In California, new heavy duty off-road engines must be designed, built and equipped to meet California's stringent anti-smog standards adopted by the Air Resources Board pursuant to its authority in Chapter 1 and 2, Part 5, Division 26 of the California Health and Safety Code. In other states of the U.S.A., new non-road engines subject to the provisions of 40 CFR 1039 subpart A must be designed, built and equipped, at the time of sale, to meet the U.S. EPA regulations for nonroad engines.

KUBOTA must warrant the emission control system on your Compression Ignition engine for the period of time listed below provided there has been no abuse, vandalism, neglect, improper maintenance or unapproved modifications to your engine. This emission warranty is applicable in all states of the U.S.A., its provinces and territories regardless of whether an individual state, province, or territory has enacted warranty provisions that differ from the Federal warranty provisions. This emission warranty is also applicable in all provinces and territories of CANADA.

Your emission control system may include parts such as the fuel injection system and the air induction system. Also included may be hoses, belts, connectors and other emission-related assemblies.

Where a warrantable condition exists, KUBOTA will repair your engine at no cost to you, including diagnosis (if the diagnostic work is performed at an authorized dealer), parts and labor.

### EMISSION DESIGN AND DEFECT WARRANTY COVERAGE

The emissions warranty period for the engine begins on the original date of sale to the initial purchaser and continues for each subsequent purchaser for the period mentioned below.

The emissions warranty period for all engines rated under 19kW (25Hp) is 2000 hours of operation or two (2) years of use, whichever first occurs.

The emissions warranty period for constant speed engines rated under 37kW (50Hp) with rated speeds greater than or equal to 3000 rpm is 2000 hours of operation or two (2) years of use, whichever first occurs.

The emissions warranty period for all other engines not already listed is 3000 hours of operation or five (5) years of use, whichever first occurs.

If any emission related part on your engine is defective, the part will be repaired or replaced by KUBOTA free of charge.

### OWNER'S WARRANTY RESPONSIBILITIES

(a) As the engine owner, you are responsible for the performance of the required maintenance listed in your KUBOTA operator's manual. KUBOTA recommends that you retain all receipts covering maintenance on your engine, but KUBOTA cannot deny a warranty claim solely for the lack of receipts or for your failure to ensure the performance of all scheduled maintenance.

(b) As the engine owner, you should be aware, however, that KUBOTA may deny your warranty coverage if your engine or a part has failed due to abuse, vandalism, neglect, improper maintenance or unapproved modifications.

(c) Your engine is designed to operate on Ultra Low Sulfur Diesel Fuel only. Use of any other fuel may result in your engine no longer operating in compliance with Federal or California's emissions requirements.

(d) You are responsible for presenting your engine to the nearest dealer or service station authorized by KUBOTA when a problem exists. The warranty repairs should be completed in a reasonable amount of time, not to exceed 30 days.

(e) If you have any questions regarding your warranty rights and responsibilities or the location of the nearest authorized dealer or distributor, you should contact: KUBOTA ENGINE AMERICA CORPORATION, Service department at 1-800-532-9808, EEWRI@kubotaengine.com or KUBOTA TRACTOR CORPORATION, National Service Department at 1-800-558-2682, KubotaEmissionsWarranty@kubota.com or KUBOTA CANADA LTD at (905) 294-7477.

### COVERAGE

KUBOTA warrants to the initial purchaser and each subsequent purchaser that your engine will be designed, built and equipped, at the time of sale, to meet all applicable regulations. KUBOTA also warrants to the initial purchaser and each subsequent purchaser that your engine shall be free from defects in materials and workmanship which cause the engine to fail to conform to applicable regulations for the period mentioned above from the original date of sale.

KUBOTA shall remedy warranty defects at any authorized KUBOTA engine dealer or warranty station. Any authorized work done at an authorized dealer or warranty station shall be free of charge to the owner if such work determines that a warranted part is defective. Any KUBOTA approved or equivalent replacement part (including any KUBOTA approved aftermarket part) may be used for any warranty maintenance or repairs on emission related parts, and must be provided free of charge to the owner if the part is still under warranty.

KUBOTA is liable for damages to other engine components caused by the failure of a warranted part still under warranty. The use of replacement parts not equivalent to the original parts may impair the effectiveness of your engine emission control system. If such a replacement part is used in the repair or maintenance of your engine, and KUBOTA determines it is defective or causes a failure of a warranted part, your claim for repair of your engine may be denied.

Listed below are the parts covered by the Federal and California Emission Control Systems Warranty. Some parts listed below may require scheduled maintenance and are warranted up to the first scheduled replacement point for that part. The warranted parts are (if applicable):

- |  |                                       |   |
|--|---------------------------------------|---|
| 1) Air-Induction System                    | 4) Electronic Control System          | 6) Particulate Controls   |
| a) Intake Manifold                         | a) ECU                                | a) Any device used to capture particulate emissions.                      |
| b) Turbocharger System                     | b) Engine Speed / Timing Sensor       | b) Any device used in the regeneration of the particulate control device. |
| c) Charge Air Cooling System (Intercooler) | c) Accelerator Position Sensor        | c) Control Device Enclosures and Manifolding                              |
| 2) Catalyst or Thermal Reactor System      | d) Coolant Temperature Sensor         | d) Diesel Particulate Filter Temperature Sensor                           |
| a) Catalytic converter                     | e) Atmospheric Pressure Sensor        | e) Differential Pressure Sensor   |
| b) Exhaust manifold                        | f) Intake Pressure Sensor             | 7) Miscellaneous Items  |
| 3) Fuel Injection System                   | g) Intake Manifold Temperature Sensor | a) Closed Breather System   |
| a) Fuel Supply Pump                        | h) Intake Air Flow Sensor             | b) Hoses*, Clamps*, Fittings, Tubing*                                     |
| b) Injector                                | i) Common Rail Pressure Sensor        | c) Gaskets, Seals   |
| c) Injection Pipe                          | 5) Exhaust Gas Recirculation System   | d) Kubota supplied engine Wiring Harnesses                                |
| d) Common Rail                             | a) EGR Valve                          | e) Kubota supplied engine Elec. Connectors                                |
| e) Smoke Puff Limiter                      | b) EGR Cooler                         | f) Air Cleaner Element*, Fuel Filter Element*                             |
| f) Speed Timer                             | c) EGR Valve Opening Rate Sensor      | g) Emission Control Information Labels                                    |
| g) Cold Advance Timer                      |                                       |   |
| h) Injection Pump                          |                                       |   |

\*Warranty period is equivalent to manufacturer's recommended first replacement interval as stated in the applicable model's operator's manual and/or service (workshop) manual.

### MAINTENANCE REQUIREMENTS

The owner is responsible for the performance of the required maintenance as defined by KUBOTA in the operator's manual.

### LIMITATIONS

This Emission Control System Warranty shall not cover any of the following:

(a) Repair or replacement required because of misuse or neglect, improper maintenance, repairs improperly performed or replacements not conforming to KUBOTA specifications that adversely affect performance and/or durability, and alteration or modifications not recommended or approved in writing by KUBOTA.

(b) Replacement of parts and other services and adjustments necessary for required maintenance at and after the first scheduled replacement point.

## ALPHABETICAL INDEX

(S70) LOADER SPECIFICATIONS . . . . .	129	MAINTENANCE SAFETY . . . . .	69
AIR CLEANER SERVICE . . . . .	84	MONITORING THE DISPLAY PANELS . . . . .	52
ALTERNATOR BELT . . . . .	101	OPERATING PROCEDURE . . . . .	58
ATTACHMENT CONTROL DEVICE (ACD) . . . . .	42	OPERATOR CAB . . . . .	80
ATTACHMENTS . . . . .	54	OPERATOR SAFETY WARNINGS . . . . .	1
BACK-UP ALARM SYSTEM . . . . .	36	PARKING BRAKE . . . . .	33
BACK-UP ALARM SYSTEM . . . . .	78	PIVOT PINS . . . . .	105
BOBCAT COMPANY IS ISO 9001 CERTIFIED . . . . .	7	PRE-STARTING PROCEDURE . . . . .	45
BOBCAT INTERLOCK CONTROL SYSTEM (BICS™) . . . . .	113	PUBLICATIONS AND TRAINING RESOURCES . . . . .	22
BOBCAT INTERLOCK CONTROL SYSTEM (BICS™) . . . . .	32	REAR DOOR (TAILGATE) . . . . .	83
BOBCAT INTERLOCK CONTROL SYSTEM (BICS™) . . . . .	72	REGULAR MAINTENANCE ITEMS . . . . .	7
BOB-TACH . . . . .	106	SAFETY INSTRUCTIONS . . . . .	15
CONTROL IDENTIFICATION . . . . .	30	SEAT BAR RESTRAINT SYSTEM . . . . .	31
DAILY INSPECTION . . . . .	43	SEAT BAR RESTRAINT SYSTEM . . . . .	74
DELIVERY REPORT . . . . .	8	SEAT BELT . . . . .	75
DRIVE BELT . . . . .	102	SERIAL NUMBER LOCATIONS . . . . .	8
DRIVING AND STEERING THE LOADER . . . . .	38	SERVICE SCHEDULE . . . . .	71
ELECTRICAL SYSTEM . . . . .	91	SPARK ARRESTER MUFFLER . . . . .	98
EMERGENCY EXIT . . . . .	35	STARTING THE ENGINE . . . . .	48
ENGINE COOLING SYSTEM . . . . .	89	STOPPING THE ENGINE AND LEAVING THE LOADER . . . . .	53
ENGINE LUBRICATION SYSTEM . . . . .	88	STOPPING THE LOADER . . . . .	38
ENGINE SPEED CONTROL . . . . .	37	TIRE MAINTENANCE . . . . .	99
FEATURES, ACCESSORIES AND ATTACHMENTS . . . . .	10	TOWING THE LOADER . . . . .	62
FINAL DRIVE TRANSMISSION (CHAINCASE) . . . . .	100	TRACTION LOCK OVERRIDE . . . . .	34
FIRE PREVENTION . . . . .	17	TRANSPORTING THE LOADER ON A TRAILER . . . . .	63
FUEL SYSTEM . . . . .	85	TROUBLESHOOTING . . . . .	111
HYDRAULIC CONTROLS . . . . .	39	WARRANTY . . . . .	135
HYDRAULIC / HYDROSTATIC SYSTEM . . . . .	95		
INSTRUMENT PANEL IDENTIFICATION . . . . .	27		
LIFT ARM BYPASS CONTROL . . . . .	33		
LIFT ARM SUPPORT DEVICE . . . . .	76		
LIFTING THE LOADER . . . . .	63		
LOADER IDENTIFICATION . . . . .	9		
LOADER STORAGE AND RETURN TO SERVICE . . . . .	107		
LUBRICATING THE LOADER . . . . .	103		
MACHINE SIGN TRANSLATIONS . . . . .	117		
MACHINE SIGNS (DECALS) . . . . .	20		



**Bobcat®**