

# Operator's Manual

Track excavator

# ET16



<b>Machine model</b>	<b>E09-02</b>
<b>Edition</b>	<b>1.0</b>
<b>Document order number</b>	<b>1000365220</b>
<b>Language</b>	<b>en</b>
<b>From serial number</b>	<b>WNCE0902PPAL00131</b>



**WACKER  
NEUSON**

Documentation	Language	Order no.
Operator's Manual	en	1000365220
Spare parts list ET16 (E09-02)	de/en/fr	1000361160
Spare parts list ET16 (E09-02)	it/es/en	1000361311

Legend	
Original Operator's Manual	x
Issue	1.0
Date	05/2016
Document	BA ET16 de*

Copyright © 2016 Wacker Neuson Linz GmbH, Hörsching

Printed in Austria

All rights reserved, in particular the copyright, the right of reproduction and the right of distribution applicable worldwide.

This document may be used by the receiver only for the designated purpose. It may in no way be duplicated or translated in any other language, in whole or in part, without prior permission in writing from the manufacturer.

No reproduction or translation of this publication, in whole or part, without the written consent of Wacker Neuson Linz GmbH.

Violations of legal regulations, in particular of the copyright protection, will be subject to civil and criminal prosecution.

Wacker Neuson Linz GmbH keep abreast of the latest technical developments and constantly improve their products. For this reason, we may from time to time need to make changes to figures and descriptions in this documentation that do not reflect products that have already been delivered and that will not be implemented on these machines.

Technical data, dimensions and weights are only given as an indication. Responsibility for errors or omissions not accepted.

The cover features the machine with possible optional equipment.

Photographs and graphics are symbolic representations and may differ from the actual products.

The Operator's Manual and any amendments to it must always be available at the place of use of the machine. Possible amendments are included at the end of the Operator's Manual.



Wacker Neuson Linz GmbH  
 Flughafenstr. 7  
 A-4063 Hörsching  
 Phone: +43 (0) 7221 63000  
 Fax: +43 (0) 7221 63000-2200  
 E-mail: office.linz@wackerneuson.com  
 www.wackerneuson.com

# Table of contents

<b>1 Foreword</b>	
1.1 Operator's Manual .....	1-1
1.2 Warranty and liability .....	1-8
<b>2 Safety</b>	
2.1 Safety symbols and signal words .....	2-1
2.2 Qualification of operating personnel .....	2-2
2.3 Conduct .....	2-3
2.4 Operation .....	2-4
2.5 Lifting gear applications .....	2-8
2.6 Trailer operation .....	2-10
2.7 Attachment operation .....	2-10
2.8 Towing, loading and transporting .....	2-11
2.9 Maintenance .....	2-13
2.10 Measures for avoiding risks .....	2-17
<b>3 Introduction</b>	
3.1 Machine overview .....	3-1
3.2 Brief description of machine .....	3-2
3.3 Information and regulations on use .....	3-4
3.4 Labels .....	3-5
<b>4 Putting into operation</b>	
4.1 Cabin .....	4-1
4.2 Overview of control elements .....	4-23
4.3 Indicator lights and warning lights (overview) .....	4-28
4.4 Preparatory work .....	4-30
4.5 Starting and stopping the engine .....	4-34
<b>5 Operation</b>	
5.1 Steering system .....	5-1
5.2 Accelerator actuation .....	5-1
5.3 Brakes .....	5-3
5.4 Machine travel .....	5-4
5.5 Differential lock .....	5-8
5.6 Lights/signalling system .....	5-9
5.7 Wiper/wash system .....	5-12
5.8 Heating and ventilation .....	5-12
5.9 Work hydraulics .....	5-13
5.10 Attachments .....	5-41
5.11 Work operation .....	5-45
5.12 Emergency lowering .....	5-52
5.13 Options .....	5-53
5.14 Putting out of operation/back into operation .....	5-55
5.15 Permanently putting out of operation .....	5-57
<b>6 Transportation</b>	
6.1 Towing the machine .....	6-1
6.2 Loading the machine .....	6-3
6.3 Transporting the machine .....	6-8



<b>7</b>	<b>Maintenance</b>	
7.1	Information on maintenance .....	7-1
7.2	Maintenance overview .....	7-4
7.3	Fuel, lubricants and coolants .....	7-12
7.4	Maintenance accesses .....	7-14
7.5	Cleaning and maintenance .....	7-21
7.6	Lubrication work.....	7-24
7.7	Fuel system .....	7-24
7.8	Engine lubrication system.....	7-29
7.9	Cooling system .....	7-31
7.10	Air filter.....	7-34
7.11	V-belt .....	7-36
7.12	Hydraulic system .....	7-37
7.13	Electrical system.....	7-41
7.14	Heating, ventilation and air conditioning system.....	7-42
7.15	Washer system .....	7-42
7.16	Axles/travelling drive .....	7-42
7.17	Braking system .....	7-42
7.18	Tracks .....	7-43
7.19	Maintenance of attachments.....	7-46
7.20	Maintenance of options.....	7-46
7.21	Exhaust gas treatment.....	7-46
7.22	Machine preservation .....	7-46
<b>8</b>	<b>Malfunctions</b>	
8.1	Diesel engine malfunctions.....	8-1
8.2	Malfunctions of the travelling drive .....	8-2
8.3	Malfunctions of the hydraulic system.....	8-2
8.4	Malfunctions of the electrical system .....	8-3
8.5	Malfunctions in the air conditioning system .....	8-3
8.6	Disorders of attachments.....	8-3
<b>9</b>	<b>Technical data</b>	
9.1	Models and trade names .....	9-1
9.2	Engine.....	9-1
9.3	Traveling drive/axles .....	9-3
9.4	Brake .....	9-3
9.5	Tracks .....	9-3
9.6	Steering system .....	9-3
9.7	Operating hydraulics .....	9-3
9.8	Electrical system .....	9-4
9.9	Tightening torques .....	9-7
9.10	Coolant .....	9-8
9.11	Noise emissions.....	9-8
9.12	Vibration.....	9-9
9.13	Weight.....	9-13
9.14	Lift capacity/load .....	9-17
	<b>Index</b>	
	Index .....	S-1



**EC Declaration of Conformity****Manufacturer**

Wacker Neuson Linz GmbH, Flughafenstr. 7, 4063 Hörsching, Austria

**Product**

Machine designation	<b>Hydraulic excavator</b>
Model/version	<b>E09-02</b>
Trade name	<b>ET16</b>
Serial number	--
Output in kW	<b>13,2</b>
Measured sound power level dB(A)	<b>93</b>
Guaranteed sound power level dB(A)	<b>93</b>

**Declaration of conformity**

Notified body according to Directive 2006/42/EC, appendix XI:

**Notified body involved in procedure**

Fachausschuss Bauwesen, Landsberger Str. 309, 80687 Munich, Germany

**Directives and standards**

We hereby declare that this product corresponds to the relevant regulations of the following Directives and standards:

2006/42/EC, 2005/88/EC, 2000/14/EC;

DIN EN ISO 12100:2010, DIN EN 474-1:2006+A1:2009, DIN EN 474-5:2012 (except for C.3.3), DIN EN ISO 3471:2010, DIN EN ISO 3744:2010, DIN EN ISO 3449:2008

**Authorized representative for the compilation of technical documentation**

Thomas Köck, team leader technical documentation

Flughafenstr. 7

4063 Hörsching

Austria

---

Johannes Mahringer,  
Managing director

The indications specified above correspond to the existing information at time of going to press. They have possibly changed in the meantime (refer to the original declaration of conformity supplied with the machine). Applies to EU countries, and countries with legislation similar to that of the EU. Applies to all machines with CE marks that have not been modified without authorization since the product was placed on the market.



---

Notes:

# 1 Foreword

## 1.1 Operator's Manual

### Information on this Operator's Manual

The Operator's Manual is stored in the storage box behind the operator seat.

This Operator's Manual contains important information on how to work safely, correctly and economically with the machine. Therefore, it is aimed not only at new personnel, but it also serves as a reference for experienced personnel.

Furthermore, the reliability and the service life of the machine will be increased by following the instructions in the Operator's Manual. This is why the Operator's Manual must be kept at hand in the machine.

The operator must carefully read and understand the Operator's Manual before starting up, servicing or repairing the machine.

This Operator's Manual will help to familiarize yourself more easily with the machine, thereby enabling you to use it more safely and efficiently.

This Operator's Manual does not include special superstructures.

Please contact your dealer if you require more information on the machine or the Operator's Manual.

---

## Explanation of symbols and abbreviations

### Explanation of symbols

- Identifies a list
  - Identifies a subdivision of a list
  - Description of a result

1. Identifies an activity  
Follow the order of the activity!
2. Continuation of an activity  
Follow the order of the activity!

**A** Identifies an alphabetical list

**B** Continuation of an alphabetical list

Cross-references: see page [1-1](#) (page)

Cross references: **7** (pos. no. or table no.)

Cross-references: [Fig. 5](#) (Fig. no. 1)

Cross references: – [see chapter “5.2 Accelerator actuation” on page 5-1](#)  
(see chapter)

Cross references: – [see “Accelerator actuation” on page 5-1](#) (– see text)



### Information

Identifies an information that, when followed, provides for a more efficient and economical use of the machine.



### Environment

Failure to observe the instructions identified by this symbol can cause damage to the environment.

---

**Abbreviations**

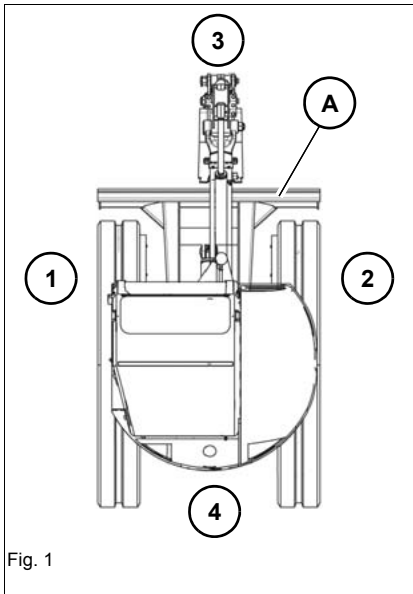
Fig.	=	Figure
AUX	=	Additional control circuit
B	=	Width
o/h	=	Operating hours
approx.	=	approximately
DPF	=	Diesel particulate filter
FGPS	=	Front Guard Protective Structure
FOPS	=	Falling Objects Protective Structure
if nec.	=	if necessary
Hydraulic quick-hitch	=	Hydraulic quickhitch (for example Easy Lock)
max.	=	maximum
min.	=	minimum
MSWS	=	Mechanical quickhitch
Pos.	=	Position
hp	=	Stabilizer blade
ROPS	=	Roll Over Protective Structure (without losing contact with the ground)
TOPS	=	Tip Over Protective Structure
e. g.	=	for example

## Glossary

Attachment	All exchangeable equipment (for example buckets) released by Wacker Neuson and developed for work with the machine.
Working lights	The lights on the roof, chassis and boom are referred to as working lights.
Towing	The excavator is towed out of an immediate danger zone (railroad crossing or job site, for example).
Canopy	Open unglazed driver's cab
DOC	Diesel oxidation catalytic converter; removes carbon monoxide and residues of unburned fuel from the exhaust fumes
DPF	Diesel particulate filter; burns soot particles in the exhaust fumes
Operating company/person	A company (or person) operating the machine. This can be a job site operating company, for example.
Operators	Person performing machine travel or operation.
Machine	Unless otherwise specified, the term " <b>machine</b> " refers to the excavator described in this Operator's Manual. In some cases the machine is also referred to as excavator to avoid confusion with other vehicles.
Machine operation	All work (for example machine travel, moving material, daily maintenance) an operator is allowed to or has to perform in connection with the machine. The term " <b>machine operation</b> " does not include maintenance only a Wacker Neuson service center is allowed to perform.
Lift capacity table	The maximum weight which may be lifted in excavating operations. If the upper carriage is rotated, pay attention to the values of the <b>load diagrams</b> .
Cab/cabin	Enclosed glazed cab
Crawling speed	Perform machine travel as slowly as possible and jerk free.
Hose rupture	Hydraulic oil under pressure escapes from a hydraulic hose.
Check the threaded fittings for tightness	<ul style="list-style-type: none"> <li>• Operator: Visually check the screwed connections and corresponding elements/subassemblies visually or manually (without using tools) for tightness</li> <li>• Authorized service center: if an attachment has to be used in the event of abnormalities for the control procedures, restore the screwed connection with new materials (screws, nuts)</li> </ul>
Visual aids	Visual aids are, for example, rearview mirrors, cameras, but also persons assisting the operator during machine operation.
Control lever base	The foldable control lever base on the left.
Tier III/Tier IV/DOC/DPF	The machines comply with different exhaust-gas standards depending on optional equipment. Engine variants are described separately if there are engine-specific differences (for example regarding operation) .
Load diagram	Specifies the maximum load at a given boom extension with which the upper carriage may be rotated by 360° and the excavator may travel in creep gear with the stabilizer blade raised without tipping over.
Loading weight	The actual weight of the machine at the beginning of transportation. This weight refers to machines which are equipped exclusively with options approved by Wacker Neuson.

<p>Additional control circuits</p>	<p>Additional control circuits required for certain attachments.</p> <ul style="list-style-type: none"> <li>• AUX I: auxiliary hydraulics (for example for hydraulic hammer or offset bucket)</li> <li>• AUX II: 3rd control circuit (for example for universal grab)</li> <li>• AUX III: for example Powertilt</li> <li>• AUX IV: hydraulic quickhitch (for example Easy Lock)</li> <li>• AUX V: oscillating grab</li> </ul>
------------------------------------	---

### Right/left/front/rear



These terms are used from the view of an operator in the cabin if the front of the cabin faces toward the stabilizer blade **A**.

- 1: left
- 2: right
- 3: front
- 4: rear

### Information

Any differences between the canopy and cabin are indicated separately. Otherwise, the terms **cab** or **cabin** are used.

## Target-group definition

This Operator's Manual is intended for professional construction site personnel.

Any operator must have fully read and understood this Operator's Manual completely.

A dealer or person renting the machine must instruct the operator and have this confirmed in writing.

## Operator qualification and requirements for safe operation

Among other things, safe machine operation depends on the following points:

- Machine model and its outfitting
- Machine maintenance
- Work and driving speed
- Nature of ground and work environment

The most important points are the operator's qualification and power of judgement. A well-trained operator following the Operator's Manual and maintenance plan ensures a long service life and durability of the machine.

Specific training enables the operator to acquire, among other things, the following skills:

- Correct assessment of work situations
- Feeling for the machine
- Recognition of possible risk situations
- Safe working by making the correct decisions for man, machine and the environment

The operator is at risk if the machine is not operated correctly.

Follow the operating procedures and instructions described for the machine.

Access to the machine or machine operation is prohibited for children and persons under the influence of alcohol, drugs, or medicine.



**Conversion table**

The rounded imperial values are indicated in brackets, for example 1060 cm<sup>3</sup> (64.7 in<sup>3</sup>).

<b>Volume unit</b>	
1 cm <sup>3</sup>	(0.061 in <sup>3</sup> )
1 m <sup>3</sup>	(35.31 ft <sup>3</sup> )
1 ml	(0.034 US fl.oz.)
1 l	(0.26 gal)
1 l/min	(0.26 gal/min)
<b>Unit of length</b>	
1 mm	(0.039 in)
1 m	(3.28 ft)
<b>Weight</b>	
1 kg	(2.2 lbs)
1 g	(0.035 oz)
<b>Pressure</b>	
1 bar	(14.5 psi)
1 kg/cm <sup>2</sup>	(14.22 lbs/in <sup>2</sup> )
<b>Force/output</b>	
1 kN	(224.81 lbf)
1 kW	(1.34 hp)
1 PS	(0.986 hp)
<b>Torque</b>	
1 Nm	(0.74 ft.lbs.)
<b>Speed</b>	
1 kph	(0.62 mph)
<b>Acceleration</b>	
1 m/s <sup>2</sup>	(3.28 ft/s <sup>2</sup> )

## 1.2 Warranty and liability

### Exemption from warranty and liability

#### Warranty

Warranty claims can be made only if the conditions of warranty have been observed. They are included in the General Conditions of Sales and Delivery for new machines and spare parts sold by the dealers of Wacker Neuson Linz GmbH. Furthermore, all instructions in this Operator's Manual must be observed.

Have the maintenance, delivery inspection and the entries in the service booklet performed by a Wacker Neuson service center, otherwise warranty claims will not be acknowledged.

#### Liability

- Modifying Wacker Neuson products and fitting them with additional equipment and attachments not included in the delivery program requires Wacker Neuson's written authorization, otherwise warranty and product liability for possible damage caused by these modifications shall not be applicable.
- The safety of the machine can be negatively affected by performing machine modifications without proper authority and by using spare parts, equipment, attachments and optional equipment that have not been checked and released by Wacker Neuson. Warranty and product liability for possible damage caused by these modifications shall not be applicable.
- Wacker Neuson Linz GmbH shall not be liable for personal injury and/or damage to property caused by failure to observe the safety instructions and the Operator's Manual, and by the negligence of the duty to exercise due care when:
  - handling
  - Operation
  - servicing and performing maintenance and
  - repairing the machine. This is also applicable in those cases in which special attention has not been drawn to the duty to exercise due care, in the safety instructions as well as in the Operator's and maintenance manuals.
  - Read and understand the Operator's Manual before starting up, servicing or repairing the machine. Observe all safety instructions.

## 2 Safety

### 2.1 Safety symbols and signal words

#### Explanation

The following symbol identifies safety instructions. It is used for warning against potential personal risk or danger.



#### **DANGER**

**DANGER identifies a situation causing death or serious injury if it is not avoided.**

Consequences in case of non-observance.

- ▶ Avoidance of injury or death.



#### **WARNING**

**WARNING identifies a situation that can cause death or serious injury if it is not avoided.**

Consequences in case of non-observance.

- ▶ Avoidance of injury or death.



#### **CAUTION**

**CAUTION identifies a situation that can cause injury if it is not avoided.**

Consequences in case of non-observance.

- ▶ Avoidance of injury.

---

#### **NOTICE**

**NOTICE identifies a situation that causes damage to the machine if it is not observed.**

- ▶ Avoidance of damage to property.
-

### 2.2 Qualification of operating personnel

#### Owner's duties

- Only allow specifically authorized, trained and experienced persons to operate, drive and perform maintenance on the machine.
- Do not allow persons to be trained or instructed by anyone other than an authorized and experienced person.
- Have persons to be trained or instructed practice under supervision until they are familiar with the machine and its behavior (for example with the steering and braking behavior).
- Access to the machine or machine operation is prohibited for children and persons under the influence of alcohol, drugs or medicine.
- Clearly and unequivocally define the responsibilities of the operating and maintenance personnel.
- Clearly and unequivocally define the responsibilities on the job site, also in view of traffic regulations.
- Give the operator the authority to refuse instructions by other persons that are contrary to safety.
- Have the machine serviced and repaired only by an authorized service center.

#### Required knowledge of operator

- The operator is responsible for other persons.
- Avoid any operational mode that might be prejudicial to safety.
- The specific national driving license is required.
- The machine may only be operated by authorized and safety-conscious persons who are fully aware of the risks involved in operating the machine.
- The operator and owner are obligated to operate the machine only in a safe and working condition.
- All persons working on or with the machine must have read and understood the safety instructions in this Operator's Manual before starting work.
- Follow, and instruct the operator in, legal and other mandatory regulations relevant to accident prevention.
- Observe and instruct the operator in regulations regarding road traffic and environmental protection.
- Use only the defined accesses for getting on and off the machine.
- Be familiar with the emergency exit of the machine.

#### Preparatory measures for the operator

- Before starting, check the machine whether it can be driven and operated safely.
- Tie back long hair and remove all jewelry.
- Wear close-fitting work clothes that do not hinder movement.

## 2.3 Conduct

### Prerequisites for operation

- The machine has been designed and built in accordance with state-of-the-art standards and the recognized safety regulations. Nevertheless its use can cause danger to the operator or other persons, or damage to the machine.
- Store this Operator's Manual in the place provided for this in or on the machine. Immediately replace a damaged or illegible Operator's Manual and any supplements to it.
- The machine must only be operated in accordance with its designated use and the instructions set forth in this Operator's Manual.
- The operator and owner are obligated not to put into operation or operate a damaged or malfunctioning machine.
  - If a damage or malfunction occurs during operation, put the machine out of operation immediately and secure it against restart.
  - Have all malfunctions jeopardizing the safety of the operator or other persons immediately repaired by an authorized service center.
- Do not put the machine into operation or operate it after an accident; have it inspected for damage by an authorized service center.
  - Have the seat belt replaced by an authorized service center after an accident, even if there is no visible damage.
  - Cabin and protective structures
- Remove all dirt, snow and ice from climbing aids (for example handholds, footholds, handrails).
- The owner is responsible for requiring the operating and maintenance personnel to wear protective clothing and equipment as required by the circumstances.

### 2.4 Operation

#### Preparatory measures

- Operation is only allowed with correctly installed and intact protective structures.
- Keep the machine clean. This reduces injury, accident and fire hazards.
- Safely store objects you carry with you in the places provided for this (for example in the storage compartment, drinks holder).
- Do not carry objects with you that protrude into the operator's work space. They can create another danger in case of an accident.
- Observe all safety, warning and information labels.
- Start and operate the machine only with the seat belt fastened and only from the place provided for this.
- Check the condition and the fastening of the seat belt. Have malfunctioning seat belts and mounting hardware replaced by an authorized service center.
- Before starting work, adjust the seating position so that all control elements can be reached and fully operated.
- Perform the personal adjustment at machine standstill only (for example of the operator seat, steering column).
- Ensure that all safety devices are properly installed and functional before starting work.
- Before starting work or after interrupting work, ensure that the brake, steering, signaling and light systems are functional.
- Before putting the machine into operation, ensure that nobody is in the danger zone.

## Job site

- The operator is responsible for other persons.
- Before starting work, familiarize yourself with the job site. This applies to, for example:
  - Obstacles in the job site and machine travel area
  - Any barriers separating the job site from public roads
  - Soil weight-bearing capacity
  - Existing overhead and underground lines
  - Special operating conditions (for example dust, steam, smoke, asbestos)
- The operator must know the maximum dimensions of the machine and the attachment – see “Technical data”.
- Maintain a safe distance (for example from buildings, edges of building pits).
- During work in buildings or in enclosed areas, look out for:
  - Height of the ceiling/clearances
  - Width of entries/passages
  - Maximum load of ceilings and floors
  - Sufficient room ventilation (for example risk of carbon monoxide poisoning)
- Use existing visual aids to stay aware of the danger zone.
- In conditions of darkness and poor visibility, switch on existing work lights and ensure that motorists are not blinded by these lights.
- If the existing lights of the machine are not sufficient for performing work safely, ensure additional lighting of the job site.
- Due to hot machine parts, maintain a safe distance from easily flammable material (for example from hay, dry leaves).

## Danger zone

- The danger zone is the area in which persons are in danger due to the movements of the machine, attachment and/or load.
- The danger zone also includes the area that can be affected by falling material, equipment or by parts that are thrown out.
- Extend the danger zone sufficiently in the immediate vicinity of buildings, scaffolds or other elements of construction.
- Seal off the danger zone should it not be possible to keep a sufficient safety distance.
- Stop machine operation immediately if persons do not stay clear of the danger zone.

## Carrying passengers

- Carrying passengers with the machine is PROHIBITED.
- Carrying passengers on/in attachments/tools is PROHIBITED.
- Carrying passengers on/in trailers is PROHIBITED.

### Mechanical integrity

- The operator and owner are obligated to operate the machine only in a safe and working condition.
- Operate the machine only if all protective and safety-oriented equipment (for example protective structures such as a cabin or rollbar, removable safety devices) is installed and functional.
- Check the machine for visible damage and defects.
- In case of damage and/or unusual behavior, put the machine out of operation immediately and secure it against restart.
- Have all malfunctions jeopardizing the safety of the operator or other persons immediately repaired by an authorized service center.

### Starting the engine of the machine

- Start the engine only according to the Operator's Manual.
- Observe all warning and indicator lights.
- Do not use any liquid or gaseous starting aids (for example ether or starting fuel).

### Machine operation

- Start and operate the machine only with the seat belt fastened and only from the place provided for this.
- Put the machine into operation only if visibility is sufficient (have another person guide you if necessary).
- Operation on slopes:
  - Travel/work only uphill or downhill.
  - Avoid machine travel across a slope, observe the machine's permissible inclination (and of the trailer if necessary).
  - Keep loads on the uphill side of the machine and as close as possible to it.
  - Keep attachments/work equipment close to the ground.
- Adapt the travel speed to the circumstances (for example the ground conditions, weather conditions).
- There is increased danger during backward machine travel. Persons in the blind spot of the machine cannot be seen by the operator.
  - Ensure that nobody is in the danger zone when you change the travel direction.
- Never get on a moving machine and never jump off the machine.



**Machine travel on public roads/sites**

- The specific national driving license is required.
- Observe the national regulations (for example the road traffic regulations) during machine travel on public roads/sites.
- Ensure that the machine is in compliance with the national regulations.
- In order not to blind other motorists, using the existing work lights during machine travel on public roads/site is prohibited.
- When crossing for example underpasses, bridges, tunnels, ensure that the clearance height and width is sufficient.
- The attachment fitted onto the machine must be certified for travel on public roads/sites (see for example the registration documents).
- The attachment fitted onto the machine must be empty and in transport position.
- The attachment fitted onto the machine must be equipped with the mandatory lights and protective equipment.
- Take measures against unintentional operation of the operating hydraulics.
- If the machine has different steering modes, ensure that the mandatory steering mode is selected.

**Stopping the engine of the machine**

- Stop the engine only according to the Operator's Manual.
- Before stopping the engine, lower the work equipment/attachment to the ground.

**Stopping and securing the machine**

- Unbuckle the seat belt only after stopping the engine.
- Before leaving the machine, secure it to prevent it from rolling away (for example with the parking brake, suitable wheel chocks).
- Remove the starting key and secure the machine against unauthorized operation.

### 2.5 Lifting gear applications

#### Requirements

- Have loads fastened and the operator guided by a qualified person having specific knowledge of lifting gear applications and the usual hand signals.
- The person giving instructions to the operator must stay in visual contact with the operator when fastening, guiding or removing the load (maintain visual contact).
- If this not be possible, ask one more person with the same qualifications to guide.
- The operator may not leave his seat as long as the load is raised.

#### Fastening, guiding and removing loads

- Follow the applicable specific regulations for fastening, guiding and removing a load.
- Wear protective clothing and equipment when fastening, guiding and removing loads (for example a hard hat, safety glasses, protective gloves, safety boots).
- Do not place lifting and fastening gear over sharp edges or rotating parts. Loads must be fastened so as to prevent them from slipping or falling.
- Move loads only on horizontal, level and firm ground.
- Move loads close to the ground.
- In order to avoid oscillating movements of loads:
  - Perform smooth, slow movements with the machine.
  - Use cables to guide the load (do not use hands to guide).
  - Bear in mind the weather conditions (for example the wind force).
  - Keep a minimum safety distance from objects.
- The operator may allow the load to be fastened and removed only if the machine and its work equipment are not being moved.
- Danger zones must not overlap with the work zones of other machines.

## Lifting gear applications

- The machine must be certified for lifting gear applications.
- Observe the national regulations for lifting gear applications.
- Lifting gear applications are procedures involving raising, transporting and lowering loads with the help of lifting and fastening gear.
- The help of an accompanying person is necessary for fastening, guiding and removing the load.
- There must be nobody under the load.
- Stop the machine immediately and stop the engine if persons enter the danger zone.
- Use the machine for lifting gear applications ONLY if the mandatory lifting gear (for example a joint rod and load hook) and safety equipment (for example optical and acoustic warning devices, hose burst valve, stability table) is installed and functional.
- Use only lifting and fastening gear certified by a test/certification body, observe the inspection intervals (Use only chains and shackles. No belts, slings or cables).
- Do not use any lifting and fastening gear that is dirty, damaged or not of sufficient size.
- Do not interrupt the work process with a load attached.

### 2.6 Trailer operation

#### Trailer operation

- The machine must be certified for trailer operation.
- Observe the national regulations for trailer operation.
- The specific national driving license is required.
- Carrying passengers on/in trailers is PROHIBITED.
- Observe the maximum permissible vertical and trailer load.
- Do not exceed the permissible trailer speed.
- Trailer operation with the towing gear of the machine is prohibited.
- Trailer operation changes the machine's operating behavior, the operator must be familiar with this and act accordingly.
- Bear in mind the machine's steering mode and the trailer's turning circle.
- Before hitching/unhitching the trailer, secure it to prevent it from rolling away (for example with the parking brake, suitable wheel chocks).
- There must be nobody between the machine and the trailer when hitching a trailer.
- Hitch the trailer onto the machine correctly.
- Ensure that all equipment works correctly (for example the brakes, lights).
- Before starting machine travel, ensure that nobody is between the machine and the trailer.

### 2.7 Attachment operation

#### Attachments

- Use only attachments that are certified for the machine or its protective equipment (for example a shatter protection).
- All other attachments require the machine manufacturer's release.
- The danger zone and the work zone depend on the attachment used – see the Operator's Manual of the attachment.
- Secure the load.
- Do not overload attachments.
- Check the correct position of the lock.

#### Operation

- Carrying persons on/in an attachment is prohibited.
- Installing a work platform is prohibited.
  - Exception: The machine is certified and equipped with the necessary safety equipment.
- Attachments and counterweights modify handling, as well as the steering and braking capability of the machine.
- The operator must be familiar with these modifications and act accordingly.
- Before starting work, operate the attachment to check that it works correctly.
- Before putting the attachment into operation, ensure that nobody is in danger.
- Lower the attachment to the ground before leaving the operator seat.

## Removing and fitting attachments

- Before uncoupling or coupling hydraulic connections:
  - Stop the engine
  - Release the pressure in the operating hydraulics
- Picking up and lowering attachments to the ground requires special care:
  - Pick up and safely lock the attachment in accordance with the Operator's Manual.
  - Lower the attachment only to firm, level ground and secure it to prevent it from tipping over or rolling away.
- Put the machine and the attachment into operation only if:
  - The protective equipment has been installed and is functional.
  - The connections for the lights and the hydraulic system have been established and are functional.
- Perform a visual check of the lock after locking the attachment.
- There must be nobody between the machine and the equipment when picking up or lowering an attachment to the ground.

## 2.8 Towing, loading and transporting

### Towing

- Seal off the danger zone.
- Ensure that no one is near the towing bar or cable. The safety distance is equal to 1.5 times the length of the towing equipment.
- Observe the mandatory transport position, permissible speed and itinerary.
- A tractor vehicle of the same weight category must be used as a minimum. Furthermore, the tractor vehicle must be equipped with a safe braking system and sufficient tractive power.
- Use only towing bars or cables certified by a test/certification body, observe the inspection intervals.
- Do not use any towing bars or cables that are dirty, damaged or not of sufficient size.
- Fasten towing bars or cables only at the defined points.
- Tow away only in accordance with this Operator's Manual to avoid damage to the machine.
- Observe the national regulations (for example the light regulations) when towing on public roads/sites.

### Crane-lifting

- Seal off the danger zone.
- The crane and the lifting gear must have suitable dimensions.
- Observe the machine's overall weight – see "Technical data".
- Wear protective clothing and equipment when fastening, guiding and removing the machine (for example a hard hat, safety glasses, safety boots).
- Use only lifting and fastening gear certified by a test/certification body (for example cables, belts, hooks, shackles), observe the inspection intervals.
- Do not use any lifting and fastening gear that is dirty, damaged or not of sufficient size.
- Perform a visual check to ensure that all slinging points are neither damaged nor worn (no widening, no sharp edges, no cracks).
- Have loads fastened and crane operators only guided by experienced persons.
- The person guiding the crane operator must be within sight or sound of him.
- Observe all movements of the machine and lifting gear.
- Secure the machine against unintentional movement.
- Raise the machine only after it is safely attached and the person attaching the machine has given his approval.
- Use only the slinging points provided for fastening the lifting gear (for example cables, belts).
- Do not attach the machine by twining the lifting gear (for example cables, belts) around it.
- Ensure an even load distribution (center of gravity!) when fastening the lifting gear.
- Ensure that no one is in, on or under the machine when loading the machine.
- Observe the national regulations (for example "Merkheft Erdbaumaschinen", leaflet on earth moving machines of the German employers' liability insurance association for construction engineering).
- Load the machine only in accordance with this Operator's Manual to avoid damage to the machine.
- Do not raise a machine that is for example stuck or frozen onto the ground.
- Bear in mind the weather conditions (for example the wind force, visibility conditions).

## Transportation

- For the safe transportation of the machine:
  - The transport vehicle must have a sufficient load capacity and platform – see “Technical data”
  - The maximum weight rating of the transport vehicle must not be exceeded.
- Use only lifting and fastening gear certified by a test/certification body, observe the inspection intervals.
- Do not use any lifting and fastening gear that is dirty, damaged or not of sufficient size.
- In order to secure the machine on the platform, use only the fastening points provided for this purpose.
- Ensure that nobody is in or on the machine during transportation.
- Observe the national regulations (for example “Merkheft Erdbaumaschinen”, leaflet on earth moving machines of the German employers’ liability insurance association for construction engineering).
- Bear in mind the weather conditions (for example ice, snow).
- Ensure the minimum load on the steering axle(s) of the transport vehicle, and ensure an even load distribution.

## 2.9 Maintenance

### Maintenance

- Observe the intervals prescribed by law and those specified in this Operator’s Manual for routine checks/inspections and maintenance.
- For inspection and maintenance, ensure that all tools and service center equipment are adapted to the performance of the task described in this Operator’s Manual.
- Do not use any damaged or malfunctioning tools.
- Have hydraulic hoses replaced within stipulated intervals even if no visual defects can be detected.
- The machine and the engine must be stopped during maintenance.
- Once maintenance is over, correctly install safety equipment again that has been removed.
- Wait for the machine to cool down before touching components.

### Personal safety measures

- Avoid any operational mode that might be prejudicial to safety.
- Wear protective clothing and equipment (for example a hard hat, protective gloves, safety boots).
- Tie back long hair and remove all jewelry.
- If maintenance on a running engine cannot be avoided:
  - Only work in groups of two.
  - Both persons must be authorized and trained for the operation of the machine.
  - One person must be seated on the operator seat and stay in contact with the second person.
  - Keep a safe distance from rotating parts (for example from fan blades, belts).
  - Keep a safe distance from hot parts (for example from the exhaust system).
  - Perform maintenance only in well-ventilated rooms or rooms with an exhaust-gas suction system.
- Safely lock/support machine components before starting work.
- Apply special care when working on the fuel system due to the increased fire hazard.



## Preparatory measures

- Attach a warning label to the control elements (for example “Machine being serviced, do not start”).
- Before performing assembly work on the machine, support the areas to be serviced and use suitable lifting and supporting equipment for the replacement of parts over 9 kg (20 lbs.).
- Perform maintenance only if:
  - the machine is positioned on firm and level ground
  - the machine is secured to prevent it from rolling away (for example with the parking brake, wheel chocks), and if all attachments/the work equipment is lowered to the ground
  - the engine is stopped
  - the starting key has been removed
  - the pressure in the operating hydraulics has been released
- If maintenance has to be performed under a raised machine/attachment, support the machine/attachment (for example with a lift platform, trestles) ensuring safety and stability.
- Hydraulic cylinders or jacks alone do not sufficiently secure a raised machine/attachment.

## Measures for performing maintenance

- Perform only the maintenance described in this Operator’s Manual.
- All work that is not described in this Operator’s Manual must be performed by qualified and authorized technical personnel.
- Follow the maintenance plan – see “Maintenance plan”.
- Always use specially designed or otherwise safety-oriented ladders and working platforms to perform overhead maintenance. Do not use machine parts or attachments as a climbing aid.
- Do not use attachments/work equipment as a lift platform for persons.
- Remove all dirt, snow and ice from climbing aids (for example handholds, footholds, handrails).
- Disconnect the negative terminal of the battery before working on the electrical system.

### Modifications and spare parts

- Do not modify the machine and the work equipment/attachment (for example the safety equipment, lights, tires, straightening and welding work).
- Modifications must be approved by the manufacturer and performed by an authorized service center.
- Use only original spare parts.

### Protective structures

- The cabin, rollbar and protective screen are tested protective structures and may not be modified (for example no drilling, bending, welding).
- Perform a visual check according to the maintenance plan (for example check the fastenings for damage).
- If damage or defects are detected, have them immediately checked and repaired by an authorized service center.
- Have retrofitting work only performed by an authorized service center.
- Replace self-locking fasteners (for example self-locking nuts) by new ones after removing them.

## 2.10 Measures for avoiding risks

### Tyres

- Have repair work on the tires only performed by trained technical personnel.
- Check the tires for correct pressure and visible damage (for example cracks, cuts).
- Check the wheel nuts for tightness.
- Use only approved tires.
- The machine must have identical tires (for example profile, revolutions per mile).

### Tracks

- Repair work on tracks may be performed only by trained technicians.
- Check the tracks for correct tension and visible damage (for example cracks, cuts).
- Proceed with extreme care on slippery ground (for example on steel plates, ice), increased slipping hazard.
- Use only approved tracks.

### Hydraulic and compressed-air system

- Check all lines, hoses and threaded fittings regularly for leaks and visible damage.
- Splashed oil can cause injury and fire.
- Leaking hydraulic and compressed-air lines can cause the full loss of the brake effect.
- Have damage and leaks immediately repaired by an authorized service center.
- Have hydraulic hoses replaced by an authorized service center within stipulated intervals even if no visual defects can be detected.

### Electrical system

- Use only fuses with the specified current rating.
- In case of damage or malfunction in the electrical system:
  - Put the machine out of operation immediately and secure it against restart
  - Disconnect the battery or operate the battery master switch
  - Have the malfunction repaired
- Ensure that work on the electrical system is only performed by trained technical personnel.
- Have the electrical system checked regularly and malfunctions repaired immediately (for example loose connections, scorched cables).
- The operating voltage of machine, the attachment and the trailer must be the same (for example 12 V).

### Battery

---

#### **CALIFORNIA**

##### **Proposition 65 Warning**

Battery terminals, battery clamps, and related accessories contain lead and lead compounds. These chemicals are classified in the state of California as a cause for cancer and a reduction of fertility. Wash hands after handling.

---

- Batteries contain caustic substances (for example sulfuric acid). When handling the battery observe the specific safety instructions and regulations relevant to accident prevention.
- A volatile oxyhydrogen mixture forms in batteries during normal operation and especially during charging. Always wear gloves and eye protection when working with batteries.
- Do not perform battery maintenance near open flames.
- Perform battery maintenance only in well-ventilated areas (for example due to vapors harmful to health, explosion hazard).
- Starting the machine with battery jumper cables is dangerous if performed improperly. Observe the safety instructions regarding the battery.

### Safety instructions regarding internal combustion engines

---

#### **CALIFORNIA**

##### **Proposition 65 Warning**

Engine exhaust, some of its constituents, and certain vehicle components contain or emit chemicals known to the State of California to cause cancer and birth defects or other reproductive harm.

---

- Internal combustion engines present special hazards during operation and fueling.
- Failure to follow the warnings and safety instructions can cause serious injury or death.
- Keep the area around the exhaust system free of flammable materials.
- Check the engine and fuel system for leaks (for example loose fuel lines). Do not start or let the engine run in case of leaks.
- Breathing the exhaust fumes causes death very quickly.
- Engine exhaust contains gases you cannot see or smell (for example carbon monoxide and dioxide).
  - Never operate the machine in enclosed premises or areas (for example in pits), if there is no suitable ventilation (for example exhaust-gas filters, suction systems).
- Do not operate the machine in potentially explosive areas.
- Do not touch the engine, exhaust system and cooling system as long as the engine is still running or has not cooled down yet.
- Do not remove the radiator cap when the engine is running or hot.
- The coolant is hot, under pressure and can cause serious burns.

**Bleeding the fuel system and refueling**

- Do not bleed the fuel system or refuel near open flames.
- Bleed the fuel system and refuel only in well-ventilated areas (for example due to vapors harmful to health, explosion hazard).
- Wipe away fuel spills immediately (for example due to fire hazard, slipping hazard).
- Firmly close the fuel tank cap, replace a malfunctioning fuel tank cap.

### Handling oil, grease and other substances

- When handling oil, grease and other chemical substances (for example the battery acid, coolant), observe the safety data sheets.
- Wear appropriate protective equipment (for example protective gloves, safety glasses).
- Be careful when handling hot consumables – burn hazard.
- In polluted environment (dust, vapors, smoke, asbestos), work only with appropriate personal protective equipment (for example with a breathing mask).
- Do not operate the vehicle in radioactively, biologically or chemically contaminated areas.

### Fire hazard

- Fuel, lubricants and coolants are flammable.
- Do not put the machine into operation if there is a fire hazard.
- Do not use flammable detergents.
- Keep the area around the exhaust system free of flammable materials.
- Due to hot machine parts, maintain a safe distance from easily flammable material (for example from hay, dry leaves).
  - Stop and park the machine only in fire-protected areas.
- If the machine is equipped with a fire extinguisher, have it installed in its specific location.
- Keep the machine clean to reduce the fire hazard.

### Working near electric supply lines

- Before performing any work, the operator must check whether there are any electric supply lines in the job site.
- If there are electric supply lines, only a machine with cabin may be used (Faraday cage).
- Keep a safe distance from existing electric supply lines.
- If this is not possible, the operator must take other safety measures (for example switching off the current) in agreement with the operating company or owner of the supply lines.
- If supply lines are exposed, they must be fastened, supported and secured accordingly.
- If live supply lines are touched nevertheless:
  - Do not leave/touch the cabin (Faraday cage)
  - If possible, drive the machine out of the danger zone
  - Warn others against approaching and touching the machine
  - Have the live wire de-energized
  - Do not leave the machine until the supply lines that have been touched or damaged have been safely de-energized

### **Working near non-electric supply lines**

- Before performing any work, the operator must check whether there are any non-electric supply lines in the job site.
- If there are non-electric supply lines, the operator must take safety measures (for example switching off the supply line) in agreement with the operating company or owner of the supply lines.
- If supply lines are exposed, they must be fastened, supported and secured accordingly.

### **Behavior during thunderstorm**

- Stop machine operation if a thunderstorm is gathering, stop the machine, secure and leave it, and avoid being near it.

### **Noise**

- Observe the noise regulations (for example during applications in enclosed premises).
- Bear in mind external sources of noise (compressed-air hammer, concrete saw).
- Do not remove the sound baffles of the machine/attachment.
- Have damaged sound baffles immediately replaced (for example an insulating mat, muffler).
- Before starting work, get informed on the noise level of the machine/attachment (for example on the adhesive label) – wear ear protectors.
- Do not wear ear protectors during machine travel on public roads/sites.

### **Clean**

- Injury hazard from compressed air and high-pressure cleaners.
  - Wear appropriate protective clothes.
- Do not use any dangerous and aggressive detergents.
  - Wear appropriate protective clothes.
- Operate the machine only in a clean condition.
  - Remove all dirt, snow and ice from climbing aids (for example handholds, footholds, handrails).
  - Keep the cabin glazing and visual aids clean.
  - Keep the light system and reflectors clean.
  - Keep the control elements and indicators clean.
  - Keep the safety, warning and information labels clean, and replace damaged and missing labels by new ones.
- Perform cleaning work only if the engine is stopped and cooled down.
- Bear in mind sensitive components and protect them accordingly (for example electronic control units, relays).



Notes:



### 3 Introduction

#### 3.1 Machine overview



Fig. 2

Position	Designation	Position	Designation
1	Boom light	7	Travel gear
2	Boom	8	Track
3	Roof lights (option)	9	Stabilizer blade
4	Cabin (option)	10	Attachment (option)
5	Handholds	11	Shovel arm
6	Engine cover	12	--

## Overview of models and trade name

Machine model/machine designation	Trade name
E09-02	ET16

### 3.2 Brief description of machine

The Wacker Neuson model ET16 crawler-mounted excavator is a self-propelled work machine.

It is a powerful, highly flexible, efficient and environmentally friendly construction machine. They are mainly used for loosening and moving earth, for example for digging and filling up construction pits. A wide range of attachments offers a large number of applications, for example hammer operation or bulk-material handling with a grab.

Other application possibilities – [see chapter “Application areas and application of attachments” on page 9-14.](#)

The main components of the machine are:

- Diesel engine
- Hydraulic and electrical components
- Canopy or cabin
- Boom
- Travel gear
- Live ring
- Stabilizer blade



#### Information

The machine can be equipped with the **telematics** option (for transmitting operating data, location, etc. via satellite).

**Canopy/cabin**

The canopy or cabin has been specially designed and developed for protection in case of an accident.

- Roll-over protective structure/TOPS-tested canopy/roll-over protective structure/TOPS-tested cabin.
- Protective FOPS structure level I (option); Protective structure against falling objects.
- Shatter protection (option); Protective structure against frontal flying fragments.

A restricted work range applies to work with attachments (for example breaker) that can cause fragments to fly around – [see chapter “Job site” on page 4-20](#).

Attaching a protective Front Guard protective structure according to EN 474-5 (item 5.3.2.1) is not possible. Only perform work that does not require a protective Front Guard structure.

**Definition of FOPS/Front Guard levels****Level I:**

Protection against small falling objects (FOPS) or small objects penetrating into the cabin from the front (Front Guard), such as bricks, small pieces of concrete, tools, for machines that are used for repairing roads, landscaping work and for working on other construction sites, for example.

**Level II:**

Protection against heavy falling objects (FOPS) or heavy objects penetrating into the cab from the front (Front Guard), such as trees, pieces of rock, for machines that are used for clearance work, demolition work and forestry work, for example.

### 3.3 Information and regulations on use

#### Designated use

- The machine is intended for:
  - moving earth, gravel or rubble, for hammer and grab operation as well as for
  - working only with the attachments indicated in chapter *Application areas and application of attachments*.
  - Every other use is regarded as not designated for the use of the machine. Wacker Neuson will not be liable for damage resulting from use other than mentioned above. The user/operating company alone will bear the risk.  
Designated use also includes observing the instructions set forth in the Operator's Manual and observing the maintenance and service conditions.
- The machine may not be used on public roads.
- The vehicle is not approved for being lifted by hoists.
- Use the quickhitch only with the corresponding attachments.
- A restricted work range applies to work with attachments (for example hammer) that can cause fragments to fly around.

## 3.4 Labels

---

 **WARNING****Injury hazard due to missing or damaged labels!**

A missing, incomplete or poor indication of danger can cause serious injury or death.

- ▶ Do not remove warning and information labels.
  - ▶ Immediately replace damaged warning and information labels.
- 

 **Information**

Type, quantity, and position of the labels depend on options, country and machine.

---

### Type labels

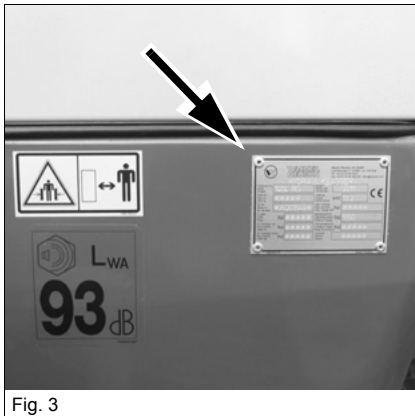


Fig. 3

The vehicle nameplate is located at the front left on the revolving superstructure.

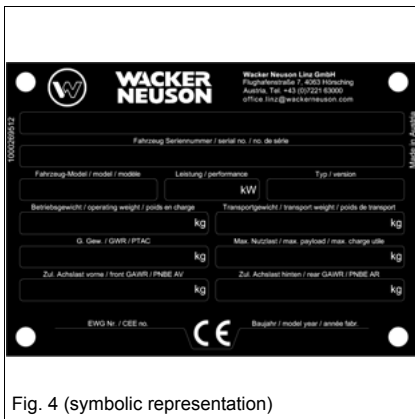


Fig. 4 (symbolic representation)

### Serial number

The serial number is stamped on the machine chassis. It is also located on the type label.

The machine type label contains the following information:

Description of attachment	HYDRAULIC EXCAVATOR
Vehicle serial no. / serial no.	Machine serial number
Fahrzeug Modell/model/modèle:	Machine designation
Leistung/performance:	Engine power
Typ/version:	Machine type
Betriebsgewicht/operating weight/poids en charge:	Operating weight
Transportgewicht/ transport weight/ poids en transport:	Transport weight
G. weight / GWR / PTAC:	Gross weight rating (permissible)
Max. Nutzlast/max. payload/max. charge utile:	Maximum payload
Zul. Achslast vorne/front GAWR/PNBE AV:	Front gross axle weight rating
Zul. Achslast hinten/rear GAWR/PNBE AR:	Rear gross axle weight rating
EWG Nr./CEE no.:	EEC check number
Baujahr/model year/année fabr.:	Year of construction



WNC	A S D E	1301	A	PAL	00400
1	2	3	4	5	6
Fig. 5:					

**17-digit serial number (from 2012)**

For easier machine identification, Wacker Neuson introduced a 17-digit serial number for compact equipment in 2012 (for example for excavators). This serial number includes additional data, for example, the manufacturer code and the production site.

Position	Description
1	Manufacturer code
2	Machine model
A	Unit
S	Compact loader
D	Dumper
E	Excavator
3	Internal model designation
4	Check letter
5	Production site
6	Serial number

** Information**

Wacker Neuson components (for example, Easy Lock, offset bucket, rollbar) have numeric serial numbers only.

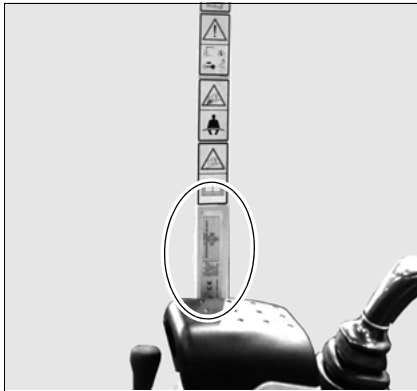


Fig. 6

#### Canopy/cabin nameplate

The type label is located on the B pillar on the left.

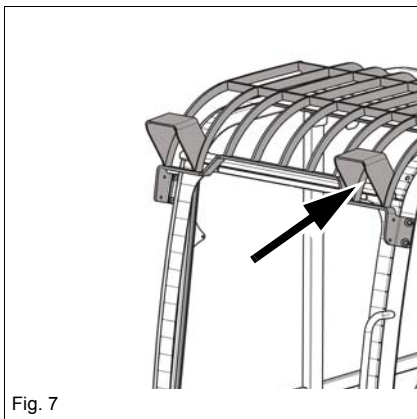


Fig. 7

#### Nameplate for FOPS-screen category I

The type label is located inside the light cover on the left.

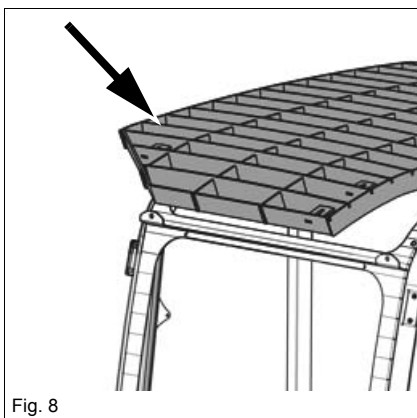


Fig. 8

#### Nameplate for FOPS-screen category II

The type label is located on the right-hand side of the protective screen.



Warning labels

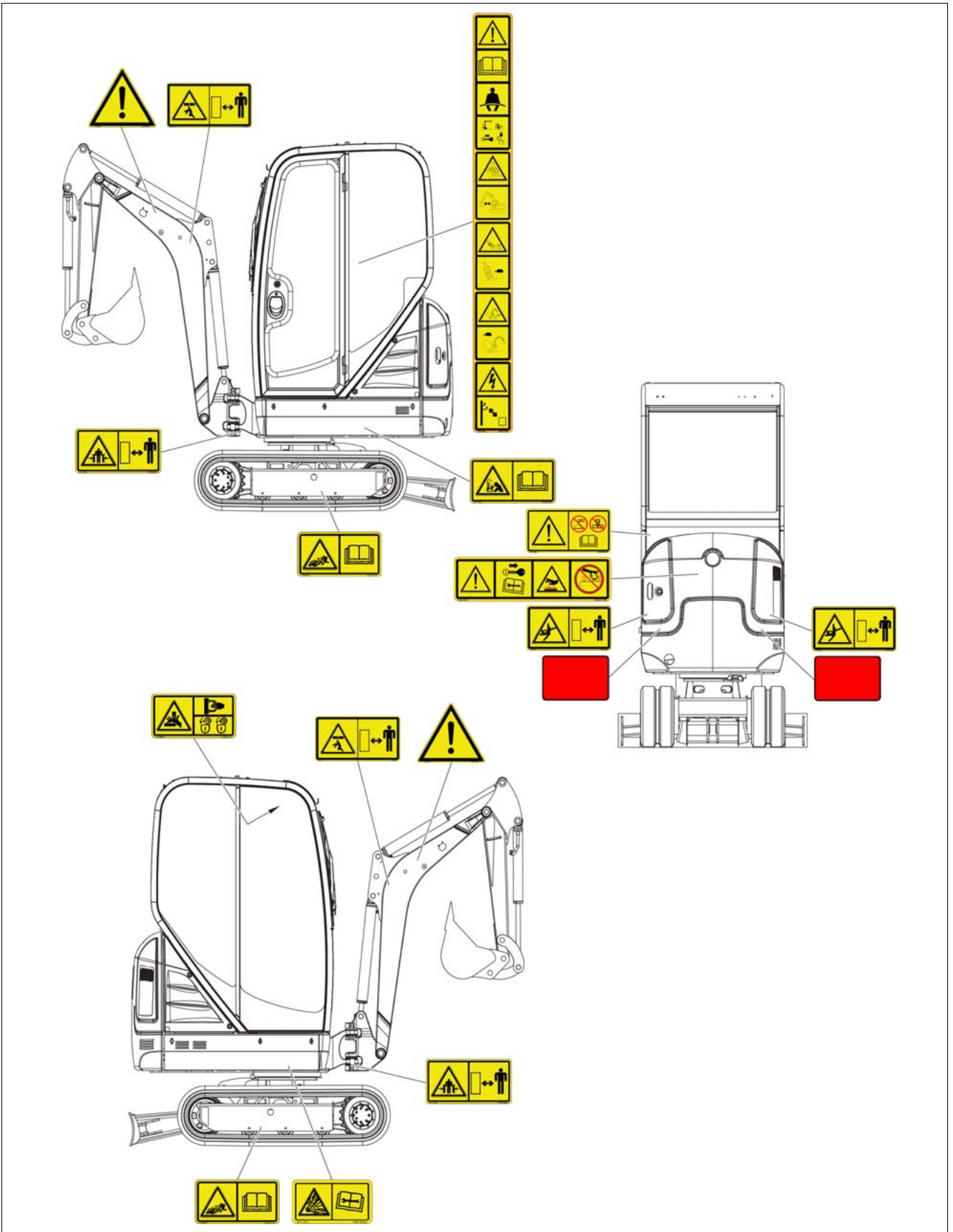




Fig. 10

**Meaning**

Crushing hazard.

All persons must stay clear of a raised load or of the danger zone.

**Position**

On the left and right side on the lifting arm.



Fig. 11

**Meaning**

Injury hazard due to grease escaping under pressure.

Read the Operator's Manual before working with the track tensioner.

**Position**

On left and right-hand undercarriage



Fig. 12

**Meaning**

Crushing hazard.

Do not allow anyone to stay in the danger zone of the machine.

**Position**

At the front left and right of the chassis



Fig. 13

**Meaning**

Crushing hazard.

Do not allow anyone to stay in the danger zone of the machine.

**Position**

On the left and right side of the engine hood



Fig. 14

**Meaning**

Explosion hazard due to wrong connection of battery jumper cables.

**Position**

Left on the chassis



Fig. 15

**Meaning**

Modifications to the structure (for example welding, drilling), retrofitting and incorrect repairs affect the protective effect of the canopy and can cause serious injury and even death.

**Position**

On the rear left of the cabin



Fig. 16

**Meaning**

Accumulator is under high pressure. Maintenance or repair work may be performed only by a Wacker Neuson service center.

**Position**

Right on the chassis



Fig. 17

**Meaning**

Crush Hazard

1. Use the handholds for opening and closing the front window.
2. Lock the window into place.

**Position**

On the left top of the front window



Fig. 18

**Meaning**

Burn hazard due to hot surfaces (lines, plug connections, hardware, hydraulic cylinders, couplings, etc.).

**Position**

On the boom on the left and right



Fig. 19

**Meaning**

Read the Operator's Manual before starting the machine.

Remove the starting key and carry it with you.

Injury hazard due to rotating parts.

- Open the engine cover only at engine standstill.

Burn hazard due to hot surfaces

- Let the engine cool down.

Burn hazard due to hot fluid

Injury hazard due to fluid escaping under pressure

- Let the engine cool down.
- Release the pressure in the hydraulic system, then open the locks carefully.

**Position**

On the engine cover

**Meaning**

Reflectors

**Position**

At the rear left and right of the machine



Fig. 20



Fig. 21

**Meaning**

Read the Operator's Manual before starting the machine.

Fasten your seat belt.

Lower the boom and the stabilizer blade to the ground.

Remove the starting key and carry it with you.

Raise the control lever base.

**Crush Hazard**

Possible serious machine damage

Keep a safe distance from the cabin.

**Crush Hazard**

Possible serious machine damage

During machine operation on slopes, pay attention to the maximum gradient angle and maximum lateral angle of inclination.

Do not drive in speed range 2.

Risk of fatal injuries due to electric shock

During machine operation, maintain a safe distance from overhead electric lines.

**Position**

On the B pillar on the left





Fig. 23

**Meaning**

Only refuel with diesel fuel with a sulfur content of < 15 mg/kg (= 0.0015 %).

**Position**

Next to the fuel tank filler inlet



Fig. 24

**Meaning**

The reservoir contains hydraulic oil.

**Position**

Next to the filler neck of the hydraulic oil tank

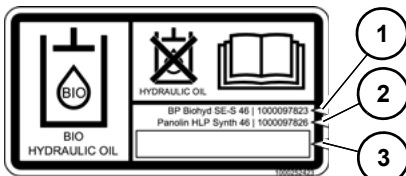


Fig. 25

**Meaning (option)**

The reservoir contains biodegradable hydraulic oil.

This label is notched on the side depending on the biodegradable hydraulic oil used.

1. BP Biohyd SE-S 46
2. Panolin HLP Synth 46
3. Other biodegradable hydraulic oil

**Position**

Next to the filler neck of the hydraulic oil tank



Fig. 26

**Meaning**

Lifting eyes

**Position**

- On the dozer blade on the left and right
- On the left and right side on the lifting arm.
- On the left and right of the cabin roof with the option **cabin lifting lugs**



Fig. 27

**Meaning**

Tie-down points

**Position**

- On the dozer blade on the left and right
- On outside left and right of the travel gear

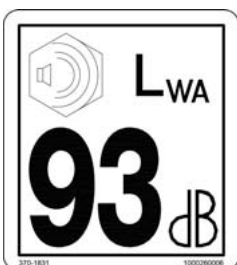


Fig. 28

**Meaning**

Indication of sound power level produced by the machine.

$L_{WA}$  = sound power level

**Position**

At the front left of the chassis

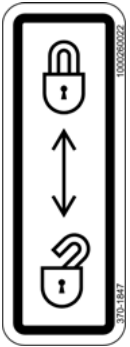


Fig. 29

**Meaning**

Hydraulic functions active or locked

**Position**

On control lever base

F2	F3	F4	F5	F6	F7	F8	F9
10A	10A	15A	10A	15A	10A	10A	15A

Fig. 30 (symbolic representation)

**Meaning**

Fuses and relays

**Position**

On the fuse box

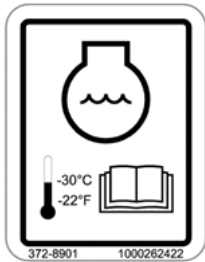


Fig. 31

**Meaning**

Coolant

**Position**

In the engine compartment on the right



Fig. 32

**Meaning**

Battery master switch

**Position**

In the engine compartment on the left





Fig. 33

**Meaning (option)**

Check before starting the machine the operating pattern that has been chosen.

Wiring diagram	Controls
A	ISO controls
B	SAE controls

**Position**

Left on the chassis

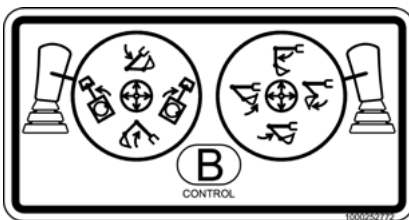


Fig. 34

**Meaning (option)**

Operating procedures differing from the ISO controls if the SAE controls are set.

**Position**

On the roof window

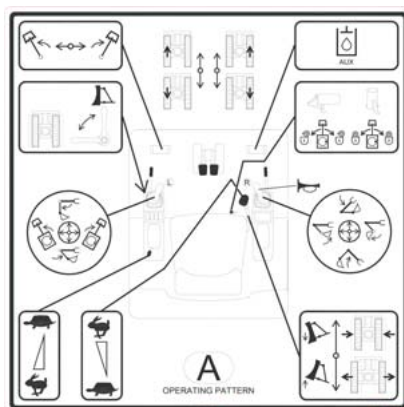


Fig. 35

**Meaning**

Functions of pedals and control levers for ISO controls. Check the selected control mode before starting the machine.

**Position**

On the headliner

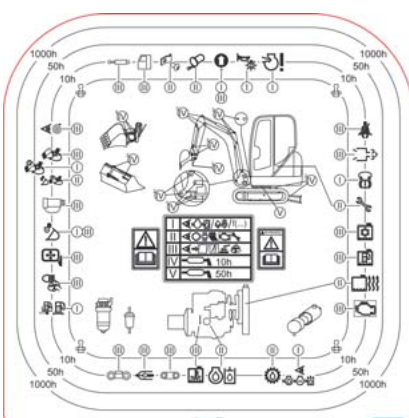


Fig. 36

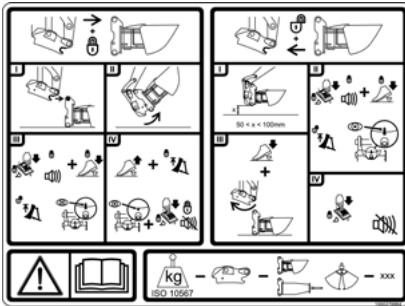
**Meaning**

Maintenance intervals

**Position**

On the roof window





**Meaning (option)**

Hydraulic Easy Lock quickhitch

**Position**

On the headliner

Fig. 37





Fig. 39

**Position**

On the headliner

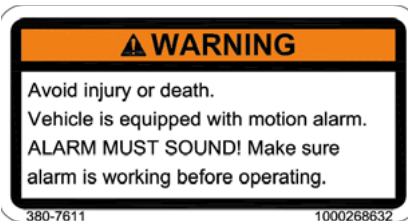


Fig. 40

**Position**

On the right top on the rear window



Fig. 41

**Position**

On the front window with the wiper motor



Fig. 42

**Position**

In the engine compartment above the air filter

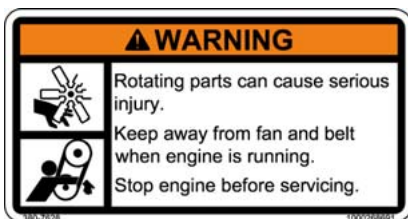


Fig. 43

**Position**

In the engine compartment above the radiator



Fig. 44

**Position**

In the engine compartment above the radiator



Fig. 45

**Position**  
On the headliner



Fig. 46

**Position**  
On left and right-hand undercarriage



Fig. 47

**Position**  
At the front left and right of the chassis



Fig. 48

**Position**  
On the headliner



Fig. 49

**Position**  
On the rear left of the cabin

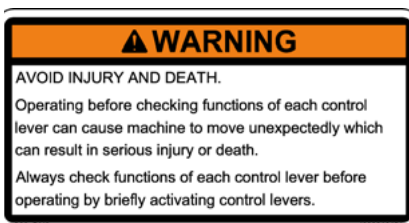


Fig. 50

**Position**  
On the headliner



Fig. 51

**Position**

On the left and right side on the lifting arm.



Fig. 52

**Position**

On the headliner

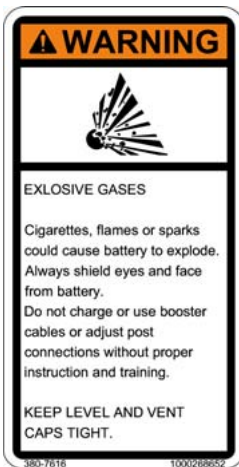


Fig. 53

**Position**

On the left side of the chassis

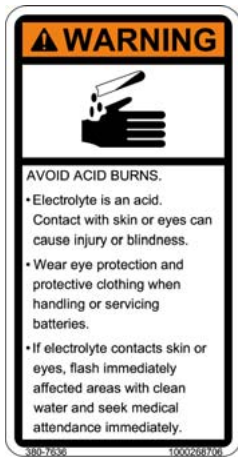


Fig. 54

**Position**

On the left side of the chassis

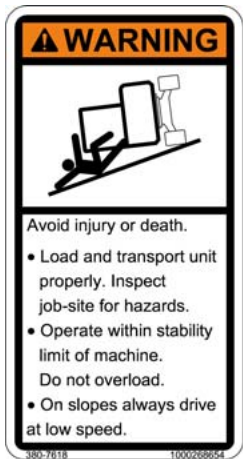


Fig. 55

**Position**

On the B pillar on the left

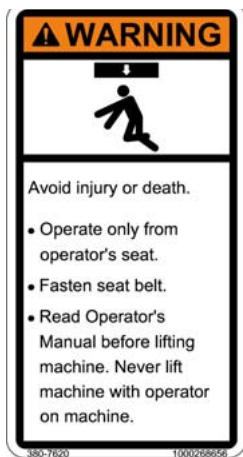


Fig. 56

**Position**

On the B pillar on the left

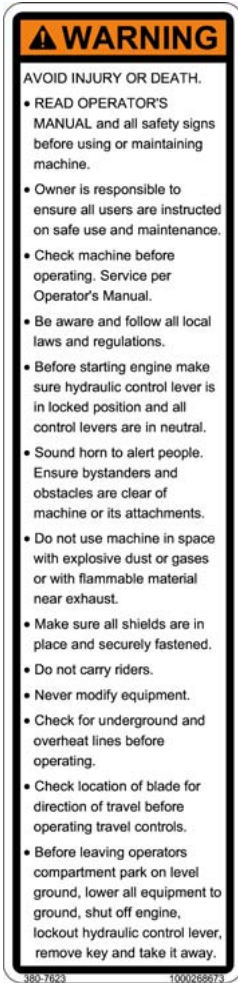


Fig. 57

**Position**

On the B pillar on the left

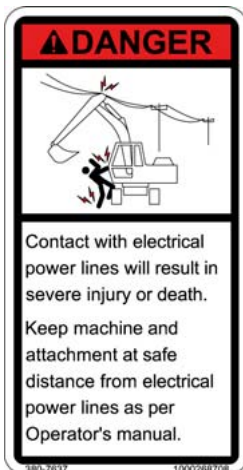


Fig. 58

**Position**

On the B pillar on the left



Fig. 59

**Position**  
On the headliner



Fig. 60

**Position**  
In the engine compartment above the radiator



Fig. 61

**Meaning**  
Do not use starting-aid sprays.  
**Position**  
On the engine cover



## 4 Putting into operation

### 4.1 Cabin

#### Safety instructions regarding entry and exit

---

 **CAUTION****Falling hazard when entering or exiting!**

Entering or exiting incorrectly can cause injury.

- ▶ Keep the mandatory climbing aids **A** clean and use only them for entering and exiting.
  - ▶ Face the machine as you enter and leave it.
  - ▶ Have damaged climbing aids replaced immediately. Do not operate the machine.
- 

 **CAUTION****Crushing hazard due to unlocked cabin door!**

Unlocked cabin doors can cause crushing.

- ▶ Lock the cabin door.
  - ▶ Use the handholds for closing.
- 

 **CAUTION****Injury hazard when opening or closing the front window!**

Opening or closing the front window can cause injury.

- ▶ Use both handles.
  - ▶ Duck your head.
  - ▶ Let both locks lock into place.
  - ▶ Keep body parts and clothes away from the window channel.
-



Fig. 62

### Entry and exit (canopy)

Shut off the machine (see chapter **Operation, shutting off the machine**).

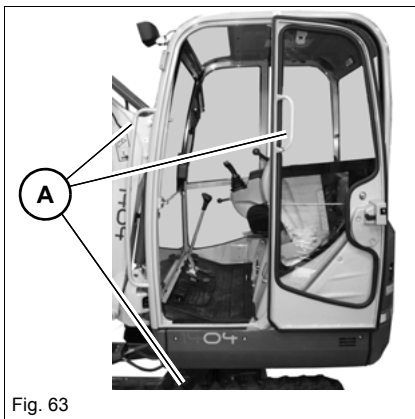


Fig. 63

### Cabin entry and exit

---

#### **i** Information

When entering or leaving the cabin, the door must be locked in the arrester.

---

#### **i** Information

You can climb on and get off the track only if the travel gear is telescopically extended.

---

## Unlocking and locking the door

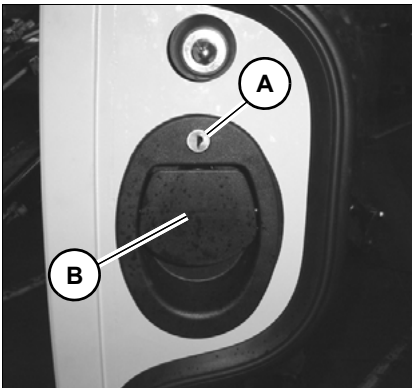


Fig. 64

### Unlocking:

Turn the key in door lock **A** anticlockwise.

### Locking:

Turn the key in door lock **A** clockwise.

## Opening and closing the door

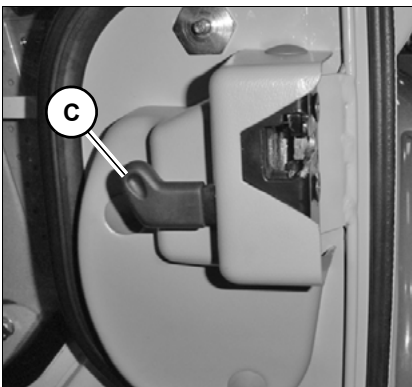


Fig. 65

### Opening:

Pull the door handle **B** down.

### Closing:

Close the door applying firm pressure.

### Opening the door from the inside:

Press lever **C** on the door lock downward.

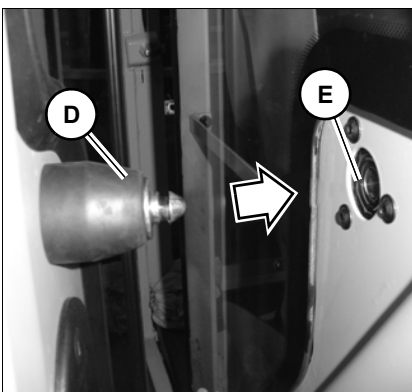


Fig. 66

### Securing an open door

Press bracket **D** firmly against arrester **E**.

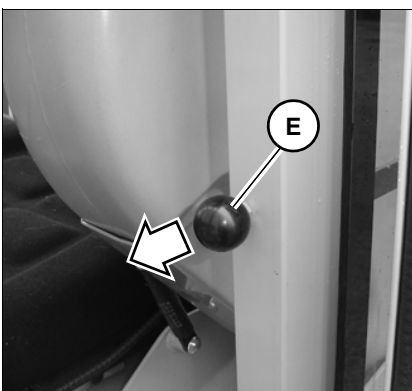


Fig. 67

### Releasing the door arrester

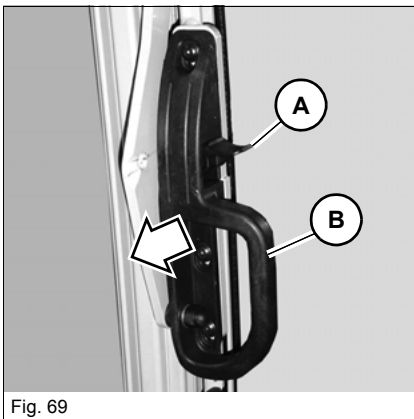
Pull button **F**.

### Opening/closing the front window

#### Opening the upper front window

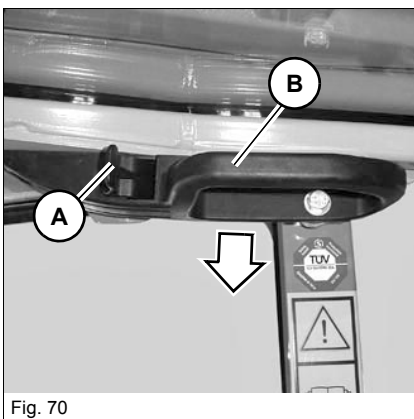


1. Press and hold levers **A** on the left and right, and pull the front window forward with handles **B** on the left and right.
2. Release levers **A** and press the window upward until it engages.



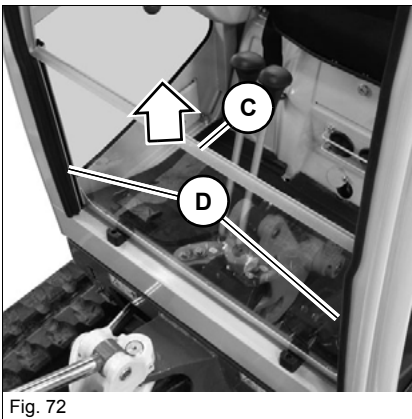
#### Closing the upper front window

1. Press levers **A** on the left and right, and pull the front window downward with handles **B** on the left and right.
2. Press the front window fully forward and release levers **A**.

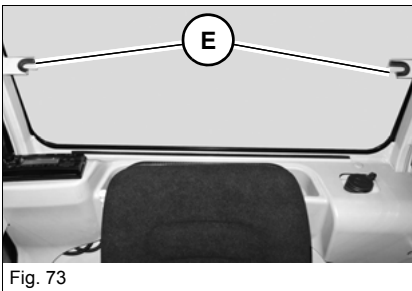




**Remove the lower front window**



Pull the lower front window **C** out of the guide **D** and place it in the guides **E** behind the operator's seat.



### Emergency exit with cabin option

The front window can be used for exiting the cabin in an emergency.

---

 **WARNING**

**Injury hazard when leaving the cabin in an emergency!**

An emergency exit can cause serious injury or death.

- ▶ The machine has neither footholds nor handholds at the front for a safe exit.
-

## Seat adjustment

---

### **WARNING**

**Accident hazard when adjusting the operator seat during machine operation!**

Adjusting the operator seat during machine operation can cause serious injury or death.

- ▶ Adjust the operator seat before putting the machine into operation.
  - ▶ Ensure that the levers are locked into place.
- 

### Weight adjustment

---

### **CAUTION**

**Spinal cord injury due to incorrect seat adjustment!**

An incorrect weight adjustment can cause injury to the spinal cord.

- ▶ Ensure that the seat is correctly adjusted to the operator's weight before machine travel or operation.
- 

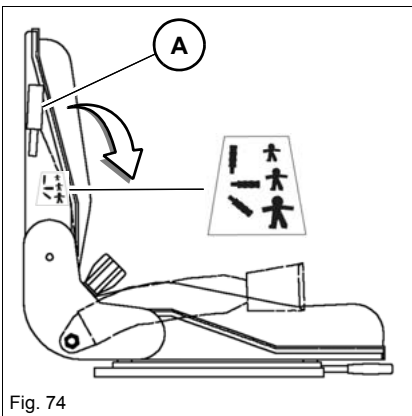


Fig. 74

No load must be applied to the seat while adjusting it.

To adjust to a higher weight:

- Turn lever **A** downward.

To adjust to a lower weight:

- Turn lever **A** upward.
- 

### **Information**

Adjust the seat suspension correctly to ensure an optimal level of ride comfort.

A label on the seat shows the correct position for a specific weight. Weight adjustment: 50 – 120 kg (110 – 265 lb).

---

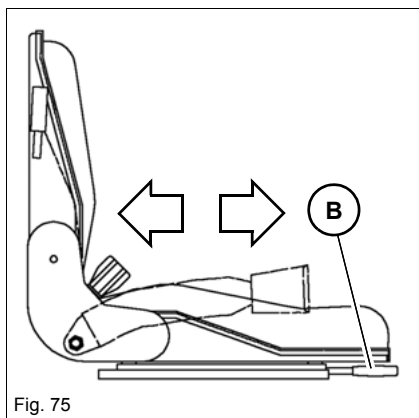


Fig. 75

### Horizontal adjustment

1. Sit down on the operator seat.
2. Pull lever **B** upward and lock seat into place in the required position.

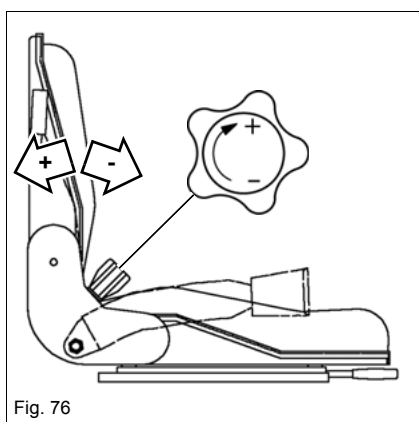


Fig. 76

### Backrest adjustment

Sit down on the operator seat.

Backrest inclination to the rear:

- Turn button toward +.

Backrest inclination to the front:

- Turn button toward -.



## Safety belt

A safety belt is included in the machine's standard equipment. Optionally, an automatic retracting seat belt may be available.

---

### **DANGER**

#### **Injury hazard if the seat belt is not fastened correctly or not at all!**

Fastening the seat belt incorrectly, or not at all, causes serious injury or death.

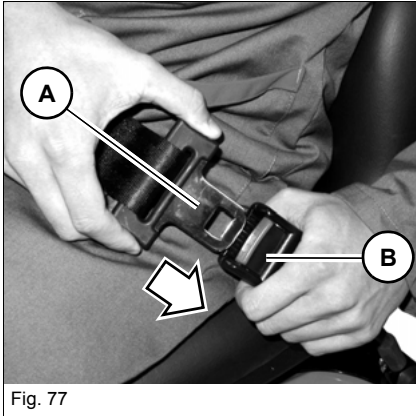
- ▶ Firmly fasten your seat belt over your hips before starting machine operation.
  - ▶ Do not fasten a twisted seat belt, and do not place it over hard, edged or fragile items in your clothes.
  - ▶ Ensure that the buckle is inserted (pull test).
  - ▶ Do not use seat belt extensions.
- 

### **CAUTION**

#### **Injury hazard due to damaged or dirty seat belt!**

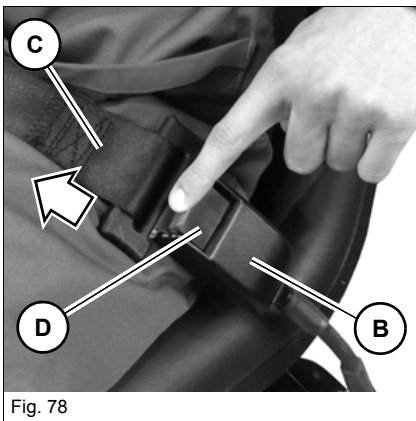
A damaged or dirty seat belt can cause serious injury or death.

- ▶ Keep the seat belt and buckle clean, and check them for damage.
  - ▶ Have a damaged seat belt and buckle immediately replaced by an authorized service center.
  - ▶ Have the seat belt immediately replaced after every accident and the load-bearing capacity of the fastening points and seat fixtures checked by a Wacker Neuson service center.
-



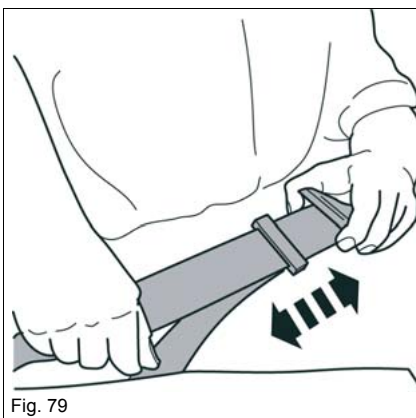
### Fastening the seat belt

Insert buckle latch **A** into seat belt buckle **B** until it engages.



### Unfastening the seat belt

Press the red push button **D** on seat belt buckle **B** until the buckle latch **C** comes out.



### Longer/shorter lap belt adjustment

Set webbing to the desired length.

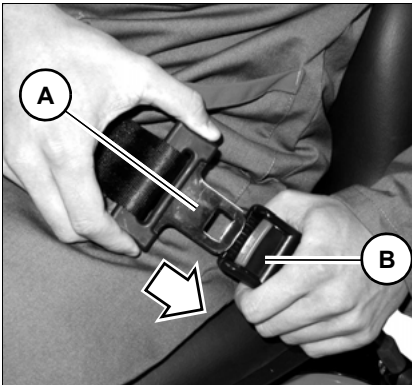


Fig. 80

### Fastening the retracting lap belt

Insert buckle latch **A** into seat belt buckle **B** until it engages.

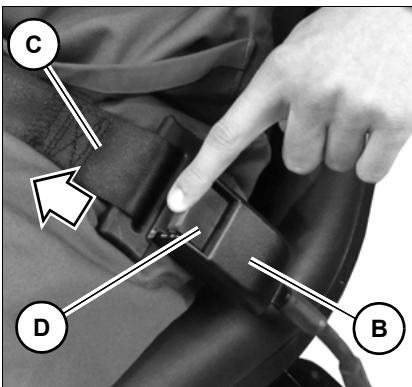


Fig. 81

### Unfastening the retracting seat belt

Press the red push button **D** on seat belt buckle **B** until the buckle latch comes out.

- ➔ Seat belt **C** is automatically retracted.

### Adjusting the mirrors (option)

---

 **WARNING****Injury hazard to persons in the danger zone!**

Persons in the danger zone are possibly not seen when reversing the machine and may be injured. This can cause accidents with serious injuries or death.

- ▶ Adjust the existing visual aids (for example the rearview mirrors) correctly.
  - ▶ Interrupt work immediately if persons enter the danger zone.
  - ▶ Pay attention to the movements and changing positions of attachments and persons.
- 

 **WARNING****Accident hazard due to restricted field of vision on the job site!**

Accidents resulting in serious injury or death can be caused by a restricted field of vision.

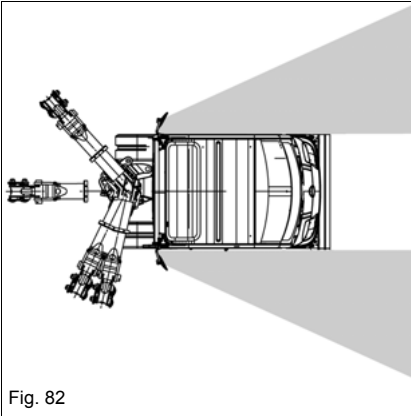
- ▶ Do not allow anyone to stay in the danger zone.
  - ▶ Use suitable visual aids if necessary (camera, mirrors, guide, for example).
  - ▶ Additional equipment or attachments must not be installed if they impair visibility.
- 

 **WARNING****Accident hazard due to incorrect adjustment of visual aids!**

Incorrectly adjusted visual aids can cause serious injury or death.

- ▶ Before starting work, ensure that all visual aids are clean, functional and adjusted in accordance with the instructions in this Operator's Manual.
  - ▶ Immediately replace damaged or broken visual aids.
  - ▶ Convex mirrors enlarge, reduce or distort the field of view.
  - ▶ The operator must follow the national and regional regulations.
- 

- Use safety-oriented ladders and work platforms for adjustment work on the machine.
- Do not use machine parts or attachments as a climbing aid.
- Set the boom to travel position before adjusting the mirrors.

**Adjusting the mirrors**

- Ensure sufficient visibility from the operator seat onto the job site.
- Ensure maximum visibility to the rear.
- Ensure visibility of the rear left edge of the machine in the mirror on the left.
- Ensure visibility of the rear right edge of the machine in the mirror on the right.

**Information**

Wacker Neuson recommends adjusting the mirrors with two persons.

**Information**

Do not make any modifications that impair visibility. Otherwise the machine does not meet the requirements for conformity and registration.

### Arm rest

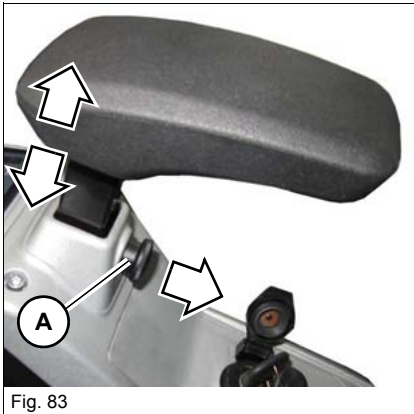


Fig. 83

1. Hold the armrest and pull out button **A**.
2. Adjust the armrest height.
3. Release button **A**.

### Fire extinguisher

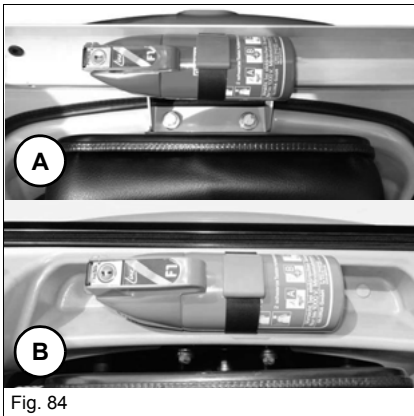


Fig. 84

A fire extinguisher is not available from Wacker Neuson.

Contact a Wacker Neuson service center for the installation of a fire extinguisher (DIN-EN 3).

**A:** Position of canopy

**B:** Position of cabin



#### Information

Ensure the firm and safe installation of the fire extinguisher. Check the fire extinguisher at regular intervals, also ensure that it is safely installed. Observe the manufacturer's indications.

## Protective structures

Protective structures are additional elements that protect the operator or user against hazards. These elements can be installed later on or as standard equipment.

---

### **DANGER**

#### **Accident hazard due to modified cabin or protective structures!**

Modifications (for example drilling) weaken the structure and can cause serious injury or death.

- ▶ No drilling, cutting or grinding.
  - ▶ Do not install any brackets.
  - ▶ No welding, straightening or bending.
  - ▶ Replace the complete protective structure if it is damaged, deformed or cracked.
  - ▶ Contact a Wacker Neuson service center in case of doubt.
  - ▶ Retrofit and repair work may only be performed by a Wacker Neuson service center.
  - ▶ Replace self-locking fasteners.
- 

### **Information**

Machine operation is only allowed with a correctly attached and intact cabin.

For additional protection, only use correctly installed and intact Wacker Neuson protective structures that have been released for the machine.

---

### **Information**

Only install protective structures with the help of a crane.

---

## Responsibility for machine equipped with protective structures

The decision regarding the necessary protective structures (type and level I or II) must be made by the machine owner and depends on the specific work situation.

The machine owner must observe the national regulations and he must inform the operator on the protective structure to be used in a specific work situation.

### Protective FOPS structure/small screen – category I (option)

---

#### **DANGER**

##### **Crushing hazard due to falling objects!**

Falling objects cause serious injuries or death.

- ▶ Install a protective FOPS structure for machine operation in areas with danger of falling objects.
- 

#### **Information**

The protective FOPS structure corresponds to category I according to ISO 3449:1992

- ▶ The machine owner must ensure that the hazard situation is evaluated and that the national regulations are observed.
  - ▶ The machine owner must ensure that only work is performed that does not require any higher protection.
  - ▶ Accidents cannot be fully avoided despite equipping a machine with protective structures.
- 

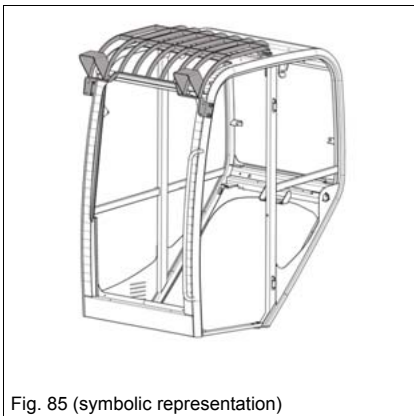
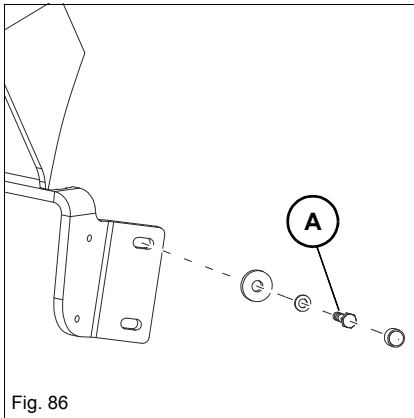
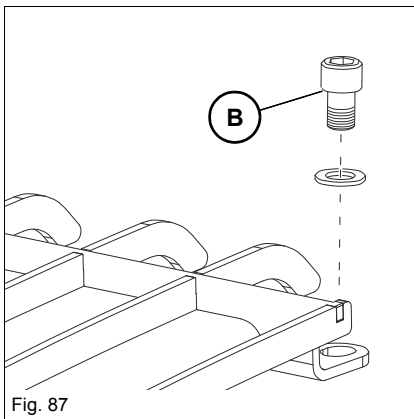


Fig. 85 (symbolic representation)



**Assembly**

1. Stop and park the machine. Stop the engine. See "Preparing lubrication".
2. Tighten hexagon head screws **A** (M6/8.8) to 10 Nm (7 ft.lbs) on the left and right.



3. Tighten hexagon socket screws **B** (M20/8.8) to 410 Nm (302 ft.lbs) on the left and right.

### Protective FOPS structure/large screen – category II (option)

---

#### **DANGER**

**Danger of crushing due to falling objects.**

Causes serious injury or death.

- ▶ Install a protective FOPS structure for machine operation in areas with danger of falling objects.
- 

#### **Information**

The protective FOPS structure corresponds to category I according to ISO 3449:1992

- ▶ The machine owner must ensure that the hazard situation is evaluated and that the national regulations are observed.
  - ▶ The machine owner must ensure that only work is performed that does not require any higher protection.
  - ▶ Accidents cannot be fully avoided despite equipping a machine with protective structures.
- 

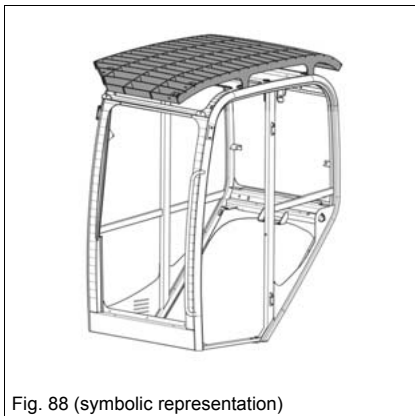


Fig. 88 (symbolic representation)

**Assembly**

1. Stop and park the machine. Stop the engine. See "Preparing lubrication".
2. Tighten hexagon head screws **C** (M8/10.9) to 35 Nm (26 ft.lbs) on either fastening point **E** on the left and right.

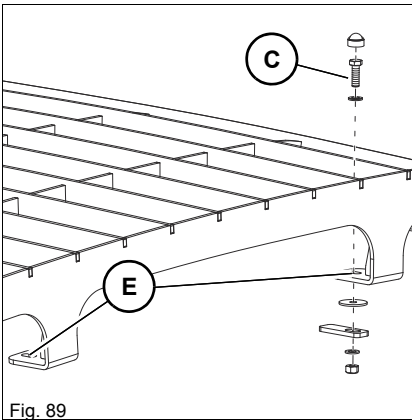


Fig. 89

### Shatter protection (option)

#### **DANGER**

##### **Danger of piercing/penetration by objects from the front!**

Work involving the danger of piercing/penetrating objects from the front can cause accidents with serious injury or death.

- ▶ To operate the vehicle, shatter protection must be installed if an attachment (a breaker, for example) causes fragments to fly around. This shatter protection takes over the function of a front window.
- ▶ Observe the prescribed work area - see [Job site](#).

#### **CAUTION**

##### **Danger of accident with restricted visibility!**

Restricted visibility (e.g. weather influences, dust) can cause serious injury or death.

- ▶ Resume work only if visibility is no longer restricted.

#### **NOTICE**

Do not use brushes, steel wool or other abrasive cleaners for cleaning the polycarbonate disk. Do not wipe dust in a dry state.

#### **Information**

The shatter protection protects the operator against fragments from the front.

- ▶ The machine owner must ensure that the hazard situation is evaluated and that the national regulations are observed.
- ▶ The machine owner must ensure that only work is performed that does not require any higher protection.
- ▶ Accidents cannot be fully avoided despite equipping a machine with protective structures.

#### **Job site**

Work range height **A**: 120 cm (47 in), **B**: 50 cm (20 in)

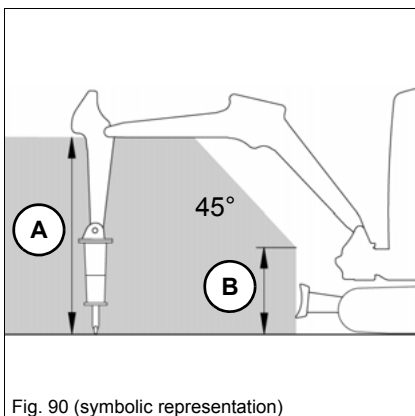
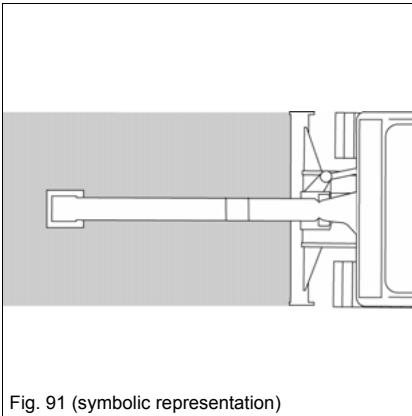
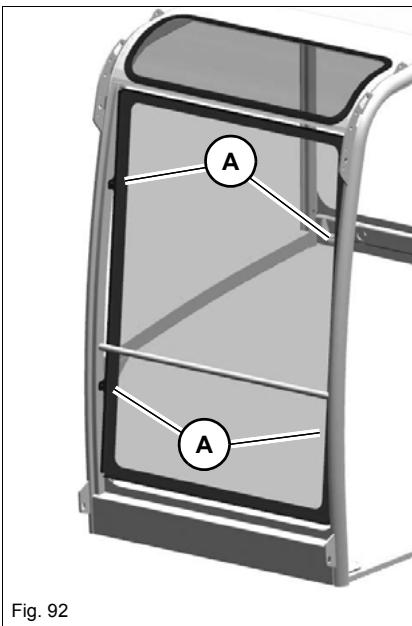


Fig. 90 (symbolic representation)

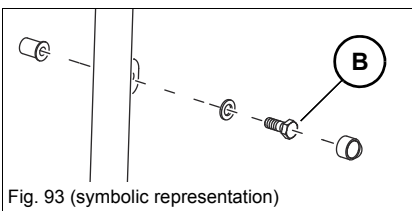


Figures 90 and 91 refer to work with a Wacker Neuson hydraulic hammer. Working with another tool can result in a different work area.



### Assembly

1. Stop and park the machine. Stop the engine. See "Preparing lubrication".
2. Tighten hexagonal bolts **B**(M8/8.8) to a torque of 25 Nm (18 ft./lbs.) at the tie-down lugs **A**.



---

### Information

Two people are required for assembly.

---

### Power outlet

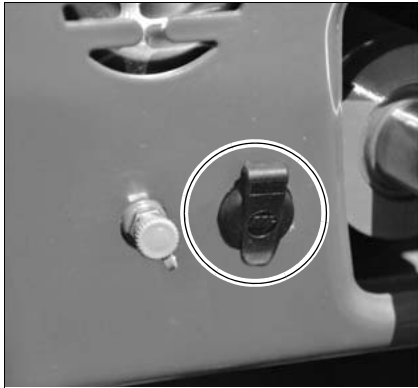


Fig. 94

12 V plug receptacles are located at the right front of the chassis and in the right rear of the cabin.

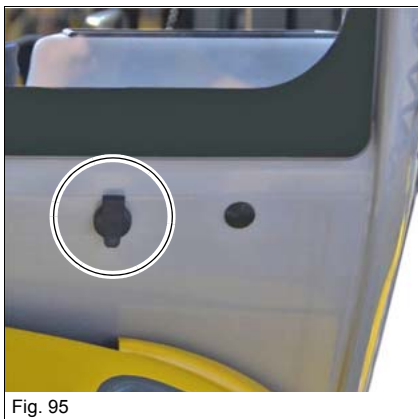


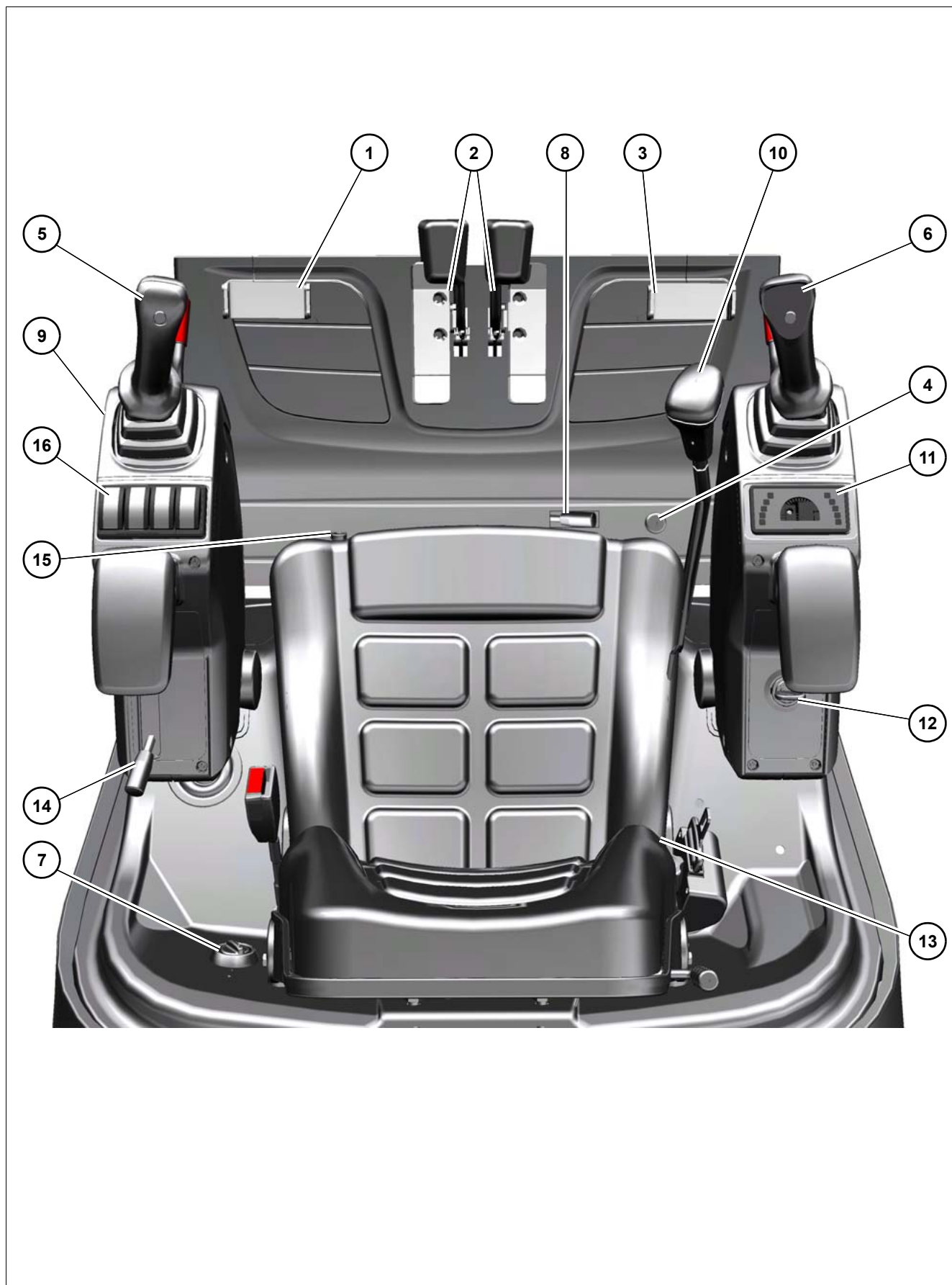
Fig. 95



## **4.2 Overview of control elements**

This chapter describes the controls, and contains information on the function and handling of the indicator lights and controls on the machine. The pages stated in the table refer to the description of the controls.

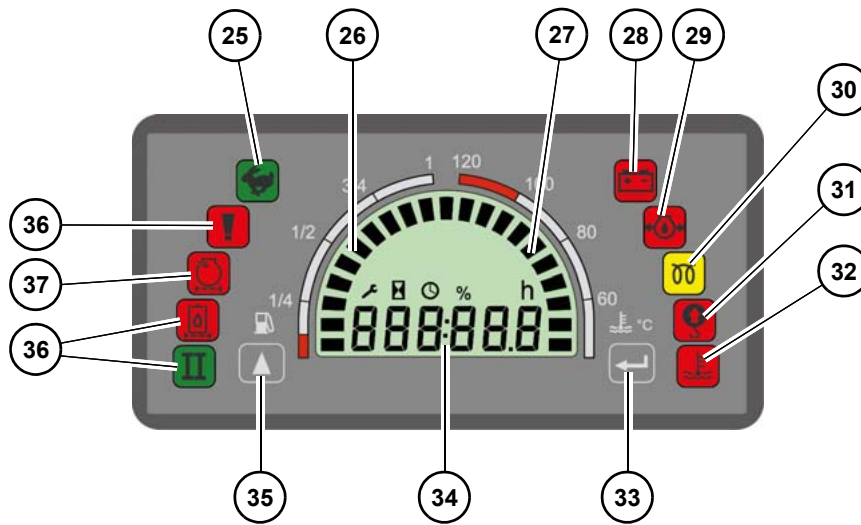
Cabin overview





<b>Designation</b>	<b>See page</b>
1 Boom swivel pedal	<a href="#">5-24</a>
2 Drive levers/accelerator pedals	<a href="#">5-1</a>
3 Auxiliary hydraulics pedal	<a href="#">5-22</a>
4 Foot-operated tip switch for hydraulic quickhitch (option)	<a href="#">5-30</a>
5 Control lever on the left	<a href="#">5-10</a>
6 Control lever on the right	<a href="#">5-13</a>
7 Temperature controller (for cabin option)	<a href="#">5-12</a>
8 Revolving superstructure lock	<a href="#">6-8</a>
9 Control lever base	<a href="#">4-35</a>
10 Stabilizer-blade lever	<a href="#">5-16</a>
11 Display element	<a href="#">4-26</a>
12 Starter	<a href="#">4-34</a>
13 Operator's seat/safety belt	<a href="#">4-7, 4-9</a>
14 Throttle	<a href="#">5-1</a>
15 Changeover for stabilizer blade/travel gear extension/retraction	<a href="#">5-16, 5-19</a>
16 Switch panel	<a href="#">4-26</a>

Display element and switches



Switch panel on control lever base on the left

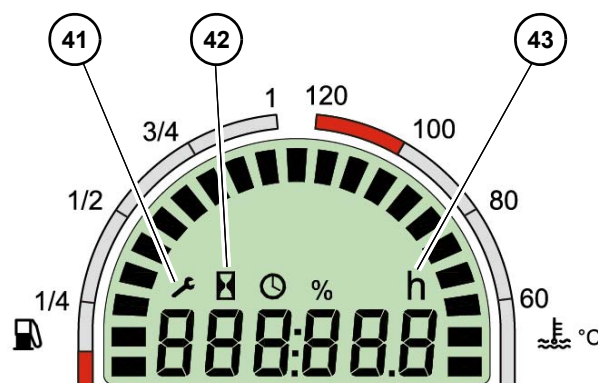
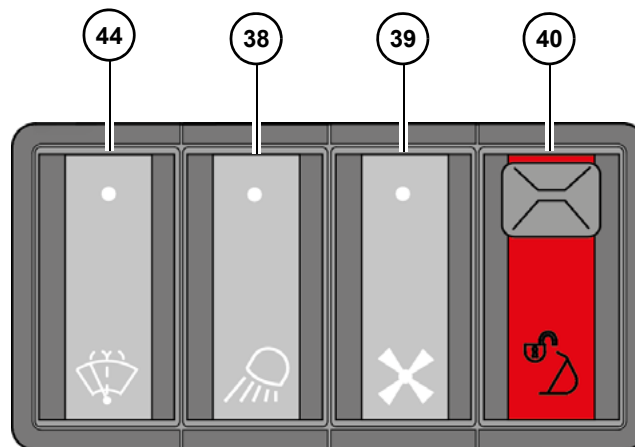


Fig. 96

Designation	See page
17 Speed range 2	<a href="#">5-2</a>
18 Fuel level indicator	<a href="#">4-29</a>
19 Coolant temperature	<a href="#">4-29</a>
20 Charge indicator light	<a href="#">4-28</a>
21 Engine oil pressure	<a href="#">4-28</a>
22 Preheating	<a href="#">4-28</a>
23 Overload warning lamp (not assigned)	--
24 Coolant temperature	<a href="#">4-29</a>
25 For Wacker Neuson service center	--
26 Hour meter/maintenance meter	<a href="#">4-29</a>
27 Hour meter/maintenance meter changeover	<a href="#">4-29</a>
28 Not assigned	--
29 Not assigned	--
30 Working lights	<a href="#">5-9</a>
31 Ventilation	<a href="#">5-12</a>
32 Hydraulic quickhitch (option)	<a href="#">5-30</a>
33 Maintenance meter	<a href="#">4-29</a>
34 Operating hours	<a href="#">4-29</a>
35 Hours	--
36 Wiper/wash system	<a href="#">5-12</a>






### 4.3 Indicator lights and warning lights (overview)


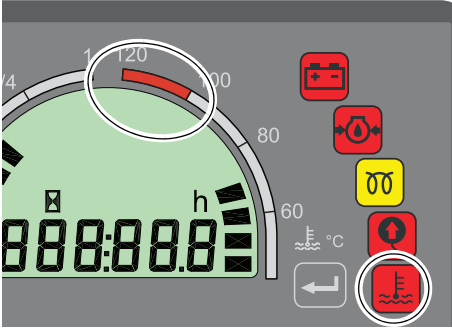
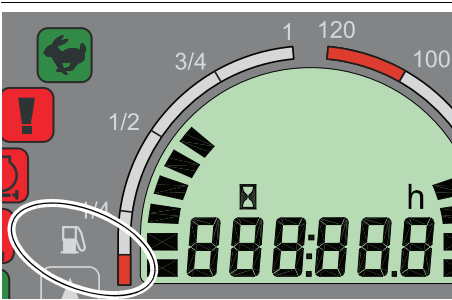
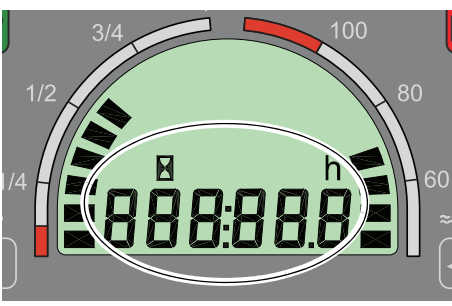
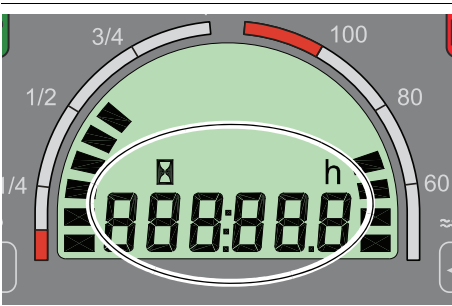

#### Display element

The display element and the multifunctional display inform the operator about operating states, required maintenance procedures and possible machine malfunctions.

#### Information

The indicator lights are tested when the starter is engaged and are illuminated for a few seconds. The maintenance counter and then the hours of operation are displayed.

Symbol	Designation
	<b>Speed range 2</b> The control lamp (green) lights up if the speed 2 is active.
	<b>Charge indicator light</b> This indicator light (red) illuminates if the electrical system has a malfunction. The battery is no longer or insufficiently charged. <b>Note:</b> This indicator light also illuminates if the starting key is turned to position 2. The indicator light goes out after the engine is started. Increase engine speed if the indicator light illuminates. The electrical system works if the indicator light of the electrical system goes out within one minute.
	<b>Engine oil pressure</b> The indicator light (red) illuminates and the buzzer sounds. <ul style="list-style-type: none"> <li>• Stop the engine immediately and check the engine oil level.</li> <li>• If the engine oil level is correct, contact a Wacker Neuson service center.</li> </ul> <b>Note:</b> The indicator light illuminates when the starter is turned on and goes out as soon as the engine runs. At low temperatures, the indicator light can illuminate a few seconds after the engine is started.
	<b>Preheating</b> The indicator light (yellow) illuminates if the starting key is in position 2. The control lamp goes out after four seconds and the engine can be started. Contact a Wacker Neuson service center if the indicator light does not go out.
	<b>Safe load indicator light</b> Not assigned

Symbol	Designation
 	<p><b>Coolant temperature</b></p> <p>The control lamp <b>A</b> lights up if the segments reach the red area.</p> <ul style="list-style-type: none"> <li>• Let the engine run at idling speed without any load.</li> <li>• Wait until the temperature drops and the indicator light goes out.</li> <li>• Stop the engine.</li> <li>• Check the coolant level.</li> </ul>
	<p><b>Fuel tank capacity</b></p> <p>Refuel if the segments reach the red range.</p>
	<p><b>Operating hour meter</b></p> <p>Counts the engine operating hours with the engine running.</p>
	<p><b>Maintenance meter</b></p> <p>Counts the remaining engine operating hours down to the next maintenance work due.</p> <p>If less than 10 hours are displayed, the wrench symbol flashes.</p>
	<p>Switch-over between <b>the operating hour meter</b> and <b>the maintenance counter</b></p>

### 4.4 Preparatory work

#### Important information before putting the machine into operation

Perform a visual check before starting work:

- There must be no leaks.
- There must be no damaged or loose parts.
- Do not allow anyone to stay in the danger zone.

Before putting the machine into operation, the operator must familiarize himself with the position of the controls and instruments.

Only operate the machine from the seat with the seat belt fastened.

Before using the machine in work operation for the first time, Wacker Neuson recommends trying out the machine on open ground without any obstacles.

When using the machine, check the surroundings constantly in order to identify potential hazards in time.

Before starting work, ensure that all visual aids are clean, functional and adjusted in accordance with the instructions in this Operator's Manual.

The operator must follow the national and regional regulations.

Perform a **functional check of the control lever base**.

Perform a **functional check of the safe load indicator**.

Do not make any modifications that impair visibility. The machine does not meet the requirements for conformity and registration.

Follow the safety instructions in chapter **Safety 2.4**.

#### Requirements and information for the operating personnel

Read, understand and follow this Operator's Manual and all other Operator's Manuals supplied with the machine.

The machine may only be put into operation by authorized personnel that has been instructed. See chapter "**Safety 2.3**".

The operator must know and bear in mind the requirements and risks at the work place.

Perform daily maintenance according to the Lubrication and maintenance plan (see chapter "**Maintenance 7.2**")

Face the machine as you enter and exit it and only use the mandatory climbing aids for entering and exiting.

Keep the footholds and the handholds clean to ensure a safe hold at all times. Immediately remove contamination, oil, snow, etc.

Do not get on a moving machine, or jump off it.

Do not operate the machine if the standard protective equipment (for example the cabin) has been removed.

No clothes or parts of the body may protrude outside the machine during operation.

## Check lists

The checklists below assist you in checking and monitoring the machine before, during, and after operation.

Wacker Neuson does not claim those lists to be exhaustive.

If the answer to one of the questions is **No**, first rectify the cause of the fault (or have it rectified) before starting work.

The checking and monitoring work listed below is described in greater detail in the following chapters.

### Start-up checklist

Check and observe the following points before putting the machine into operation or starting the engine:

No.	Question	Page
1	Enough fuel in the tank?	<a href="#">7-26</a>
2	Water in water separator and fuel filter checked and drained if necessary?	<a href="#">7-27</a>
3	Correct engine oil level?	<a href="#">7-30</a>
4	Coolant level OK?	<a href="#">7-32</a>
5	Correct oil level in the hydraulic oil reservoir?	<a href="#">7-38</a>
6	Glass cleaner in washer reservoir?	<a href="#">7-42</a>
7	Lubrication points greased?	<a href="#">7-9</a>
8	Tracks checked for cracks, cuts, etc.?	--
9	Light system, mirrors, signaling, warning and indicator lights operational and/or adjusted correctly?	--
10	Windows, mirrors, lights, steps, all pedals and control levers clean?	--
11	All control levers and pedals in neutral position?	--
12	Does the window washing system function correctly?	<a href="#">7-42</a>
13	Control lever base raised?	<a href="#">4-35</a>
14	Are other persons required to guide you?	--
15	Attachment safely locked?	<a href="#">5-30</a> <a href="#">5-43</a>
16	Engine cover locked? Filler cap closed tightly?	<a href="#">7-15</a> <a href="#">7-26</a>
17	Tools and other loose objects removed?	--
18	Seating position adjusted correctly?	<a href="#">4-7</a>
19	Are all visual aids functional, clean and adjusted correctly?	<a href="#">4-12</a>
20	Seat belt fastened?	<a href="#">4-10</a> <a href="#">4-11</a>

**Operation checklist**

Check/observe the following points before beginning operation or after starting the engine:

No.	Question	Page
1	Are there any persons or objects in the danger zone of the machine?	5-45
2	All indicator lights gone out?	4-28
3	Coolant temperature of engine in normal range?	4-29
4	Do the pedals and control levers work correctly?	5-13 5-1
5	Performed functional check of control lever base?	4-35
6	Braking effect sufficient?	5-3

**Engine shut-off checklist**

Check and observe the following points when parking the machine:

No.	Question	Page
1	Attachment lowered to the ground?	5-35 5-42
2	Stabilizer blade lowered to the ground?	5-16
3	Control lever base raised?	4-35
4	Cabin locked?	4-3

**When parking on slopes:**

5	Machine secured with wheel chocks in addition to prevent it from rolling away?	5-8
---	--	-----



## Putting into operation for the first time and running-in period

Before putting the machine into operation for the first time, check whether the equipment supplied with the machine is complete.

- Check the fluid levels according to chapter “**Maintenance**”.

Each machine is correctly adjusted and checked before it is delivered.

Handle the machine carefully during its first 50 operating hours.

- Do not load a cold engine.
- Warm up the machine at low engine speed and little load, do not warm it up at a standstill.
- Do not change engine speed abruptly.
- Avoid using the machine under heavy loads or at high speeds.
- Avoid abrupt acceleration, braking and changing travel direction.
- Do not run the engine at high speed for extended periods.
- Observe the maintenance plans – *see chapter “7.2 Wartungsübersicht” on page 7-4.*

## 4.5 Starting and stopping the engine

### Preparatory work



#### WARNING

**Accident hazard due to unintentional operation of the machine!**

Unintentional operation can cause serious injury or death.

► Only operate the machine from the seat with the seat belt fastened.

Set the throttle to the middle position if the engine is cold.

The starter cannot be actuated if the engine is already running (start repeat interlock).

Do not run the starter for more than 10 seconds.

Wait two minutes so the battery can recover and the starter does not overheat before trying again.



#### Information

Provide for sufficient ventilation when operating in enclosed areas.



#### Information

All controls must be within easy reach. You must be able to move the forward + reverse travel levers to their limit positions.

### Starter

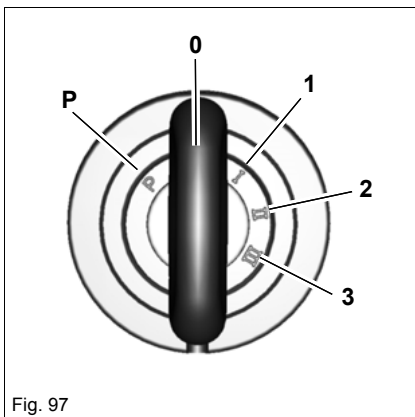


Fig. 97

Position	Function	
P	Park position	Not assigned
0	Stop position	Insert or remove the starting key
1	Machine travel position	All electric functions are enabled
2	Preheats the engine	Preheater active
3	Starts the engine	Starter is actuated

## Starts the engine

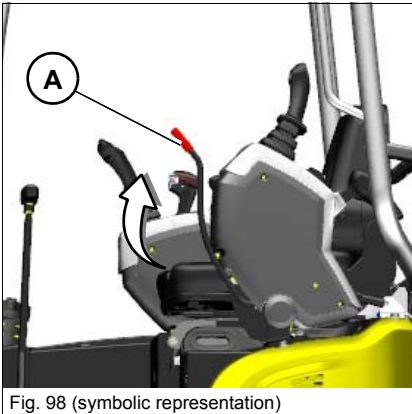


Fig. 98 (symbolic representation)

### Control lever base

Raise the control lever base **A** after stopping the engine.

### Control lever base raised:

- The engine will not start unless the control lever base is raised.

### Control lever base lowered:

- The engine cannot be started.

All hydraulic functions are locked if the control lever is raised with a running engine.

### Functional check of control lever base

Before starting work, perform a functional check of the control lever base.

1. Start the machine.
2. Fold down the control lever base **A**.
3. Perform machine travel on open terrain.
4. Secure the danger zone.
5. Stop the machine.
6. Fold up the control lever base **A**.
7. Move all control levers and pedals in all directions.
  - ➔ The selected elements do not move:
  - ➔ Work may be performed with the machine.
8. The selected elements move:
  - ➔ Stop operation immediately.

Contact a Wacker Neuson service center and have the malfunction rectified.

---

### **NOTICE**

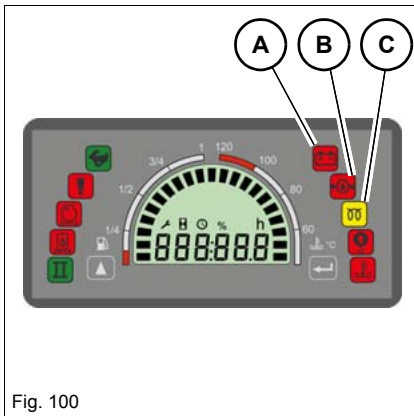
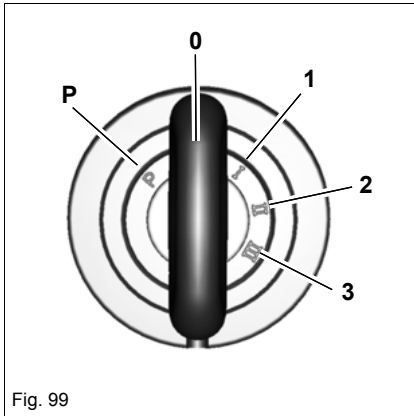
Possible damage if the engine is started again immediately after stopping it.

- ▶ Wait at least two minutes before starting the engine again.
- 

### **NOTICE**

Possible damage to preheater if the preheating system is operated too long.

- ▶ Do not preheat the engine more than five seconds.
-



1. Insert the starting key.
2. Turn the starting key to position 1.
3. All control lamps light up for a few seconds.
  - ➔ If a control lamp does not function, contact a Wacker Neuson service center.
4. Turn and hold the ignition switch key in position 2 until the control lamp for **preheating (C)** goes out.
  - ➔ The control lamp for **charge control (A)** lights up.
  - ➔ The control lamp for **engine oil pressure (B)** lights up.
5. Turn the starting key to position 3 until the engine runs.
  - ➔ All indicator lights go out.
  - ➔ If the engine does not start after 10 seconds:
6. Interrupt the start procedure and repeat it after two minutes.
  - ➔ If the engine still does not start after a few tries, contact a Wacker Neuson service center and have the error rectified.
7. Release the starting key as soon as the engine runs.

### **i** Information

The engine will not start unless the control lever base is raised.

### **Warm-up phase of machine**

After the engine has started, allow it to warm up at slightly increased idling speed until the coolant reaches its operating temperature of about 80 °C (176 °F).

Do not let the machine warm up at standstill.

Check for unusual noise, exhaust color, leaks, malfunctions, or damage.

In case of malfunctions, damage, or leaks:

Secure the machine, park it and find out the cause for the damage and have it repaired.

### **i** Information

Raise the control lever base after stopping the engine.

---

## Starting aid

---

 **WARNING****Explosion hazard in case of incorrect handling of battery!**

Incorrect battery handling can cause serious injury or death.

- ▶ Wear protective equipment.
  - ▶ Fire, open flames and smoking is prohibited
  - ▶ Do not jump start the engine if the battery is malfunctioning or frozen, or if the acid level is too low.
- 

---

 **WARNING****Injury hazard due to rotating parts!**

Rotating parts can cause serious injury or death.

- ▶ Open the engine cover only at engine standstill.
- 

---

 **CAUTION****Burn hazard due to hot surfaces!**

Can cause serious burns.

- ▶ Stop the engine and let it cool down.
  - ▶ Wear protective equipment.
- 

---

**NOTICE**

Possible damage due to electrical short circuit or overvoltage.

- ▶ The positive terminal of the starting battery must not be brought into contact with electrically conductive vehicle components.
  - ▶ The vehicles must not touch each other during the starting aid.
  - ▶ If the engine still does not start despite a starting aid, contact a Wacker Neuson service center.
-



---

### **NOTICE**

Possible damage due to wrong battery voltage.

- ▶ Only use batteries with the same voltage (12 V).

---

### **NOTICE**

Possible damage to machine with empty battery due to voltage peaks.

---

### **NOTICE**

Possible damage to battery jumper cables when placing them near rotating parts.

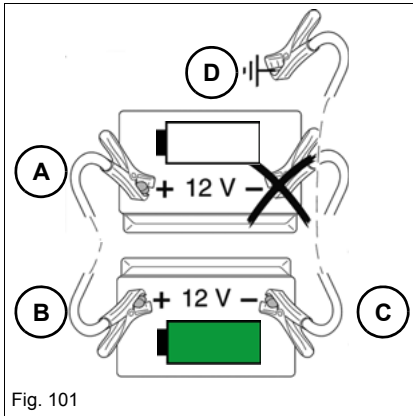
- ▶ Do not place the battery jumper cables near rotating parts.





### **Information**

Use only authorized battery jumper cables which conform to national and regional safety requirements.

---



Designations/symbols	Meaning
<b>X</b>	Machine with empty battery
<b>Y</b>	Vehicle with full battery
<b>A</b>	Positive/machine <b>X</b>
<b>B</b>	Positive/vehicle <b>Y</b>
<b>C</b>	Negative/vehicle <b>Y</b>
<b>D</b>	Negative/machine <b>X</b>
	Full battery
	Dead battery

1. Move vehicle **Y** close to machine **X** so that the length of the battery jumper cables is sufficient.
2. Stop the engine of vehicle **Y**.
3. Open the left side cover of the vehicle **X**  
– see chapter “Cover on the left” on page 7-16.
4. Open the vehicle engine hood **Y**.
5. Connect the battery jumper cables in the following order: **A – B – C – D**.
6. Start the engine of vehicle **Y**.
7. Wait five minutes for the empty battery to be charged a little.
8. Start the engine of machine **X**.
9. Switch on the boom light of machine **X** in order to avoid voltage peaks and to protect the electronic system.
10. Disconnect the battery jumper cables in the following sequence: **D – C – B – A**.

### Low-load operation

---

**NOTICE**

Possible damage to the engine due to low-load operation.

- ▶ Run the engine at idling speed or at high engine speed at over 20 % engine load.

---

Possible consequences of low-load operation are:

- Increased engine oil consumption
- Engine oil in the exhaust system causes engine contamination
- Blue smoke in exhaust gas

### Stopping the engine

---

**NOTICE**

Possible damage to the engine when it is stopped after running under high load.

- ▶ Operate the engine at idling. This avoids engine damage and increases the service life.

- 
1. Let the engine run at idling speed for five minutes without any load.
  2. Turn the starting key to "0" and remove it.

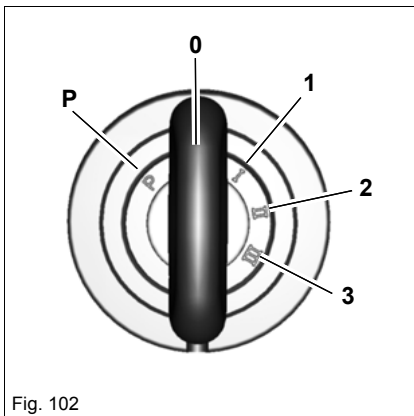


Fig. 102



## Battery master switch

### **NOTICE**

Possible damage to the electronics due to improper actuation of the battery master switch!

- ▶ Do not operate the battery master switch with a running engine.
- ▶ Operate the battery isolator switch no sooner than two minutes after shutting off the engine.

Actuate the battery isolator switch:

- If the vehicle is parked for longer periods of time (e.g. over the weekend).
- If the vehicle is to be protected against unintentional taking into service.
- If required by national and regional provisions.

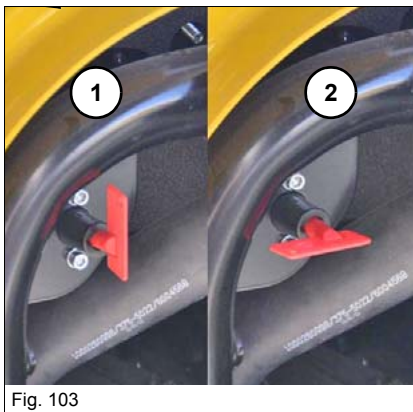


Fig. 103

The battery master switch is located in the engine compartment.





Power supply	Key position
Established	<b>1</b>
Interrupted	<b>2</b> (key removed)



Notes:

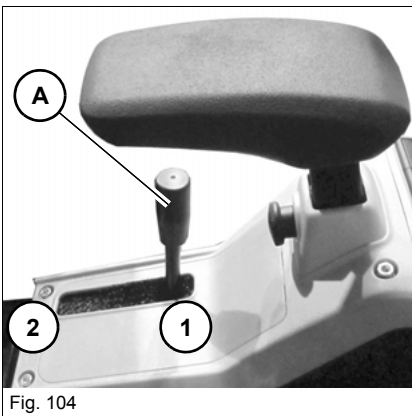
## 5 Operation

### 5.1 Steering system

Movement	Drive levers/accelerator pedals
Steering to the left	
Steering to the right	
Rotation to the left	
Rotation to the right	

### 5.2 Accelerator actuation

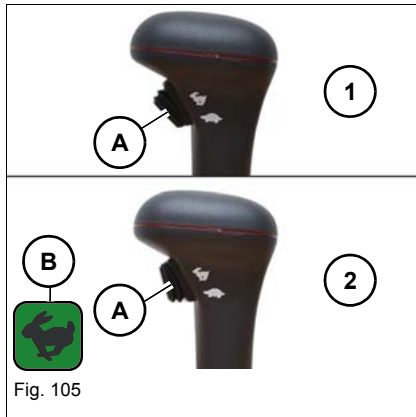
#### Manual throttle



The engine speed can be variably set with the throttle lever **A**.

Engine speed	Position
Idling speed	1
Maximum	2

### Speed range selection



The machine has two speed ranges that can be selected with the dozer blade lever.

1: Speed 1

2: Speed 2 (control lamp **B** appears in the display element)

---

#### **Information**

In speed 2, reduced tractive power jerky movements may occur when cornering due to the lower traction force.

---

## 5.3 Brakes

### Hydraulic brake

The machine will slow down when the drive levers or accelerator pedals are released.

During downhill machine travel, the automatic hydraulic brake valves prevent the machine from moving faster than the permissible travel speed.

---



#### **Information**

Reduce the speed with the drive levers or accelerator pedals, and not with the throttle.

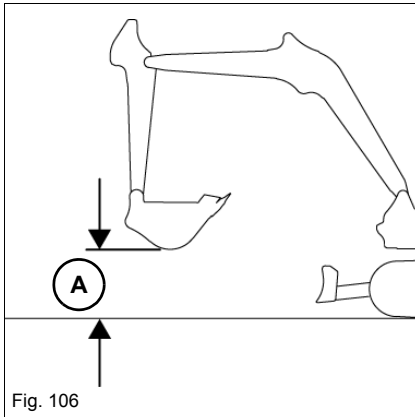
---

### Mechanical brake

The stabilizer blade is used as a parking brake. Press the stabilizer blade against the ground.

## 5.4 Machine travel

### Machine travel position



Position the machine as shown.

Position the boom at the center and raise it off the ground.

- A = 20-30 cm (8-12 in)

### Starting machine travel and stopping

#### **WARNING**

##### **Accident hazard due to incorrect machine operation!**

The machine moves in the opposite direction if the upper carriage is rotated by 180° and the drive levers are actuated.

Incorrect operation can cause serious injury and death.

- ▶ Slowly and carefully actuate the control levers.

#### **WARNING**

##### **Accident hazard due to incorrectly rotated upper carriage!**

If rotated incorrectly, the upper carriage blocks the visibility of the travel path. This may cause serious injury or death.

- ▶ Before starting machine travel on a construction site, align the upper carriage so that the operator has an unrestricted view of the travel path.

#### **Starting machine travel**

Operate the drive levers or accelerator pedals.

- The machine starts moving.

#### **Stopping**

Release the drive levers or accelerator pedals.

- The machine stops.

#### **Information**

The control lever base must be folded down in order to start machine travel.

## Operating temperature range

Operate the machine only at ambient temperatures between  $-15\text{ °C}$  ( $5\text{ °F}$ ) and  $+45\text{ °C}$  ( $+113\text{ °F}$ ).

## Machine travel on slopes



### **WARNING**

#### **Crushing hazard due to tipping over of machine!**

A tipping machine can cause serious injury or death.

- ▶ Raise the boom 20 – 30 cm (8 – 12 in) off the ground and position it straight ahead at the center of the machine.
- ▶ In an emergency, lower the boom immediately to increase stability.
- ▶ Travel on slopes only on firm and level ground.
- ▶ Adapt the travel speed to the prevailing conditions.
- ▶ Pay attention to persons and obstacles.
- ▶ Pay attention to the stability limits of the machine (maximum gradient angle  $15^\circ$ , maximum lateral angle of inclination  $10^\circ$ ).
- ▶ Perform uphill and downhill machine travel only in speed range 1.
- ▶ Never reverse downhill.
- ▶ Ensure that no parts of the body protrude outside the machine.
- ▶ Do not exceed the permissible payloads.
- ▶ Do not turn or swivel the upper carriage and the boom during downhill or uphill machine operation with a full attachment.
- ▶ Performing machine travel diagonally on slopes is prohibited.

Stones and the humidity in the upper layer of the ground can affect machine traction and stability.

The machine can slip sideways on gravel or loose, rocky soil. The stability of the machine can be reduced on rough terrain.

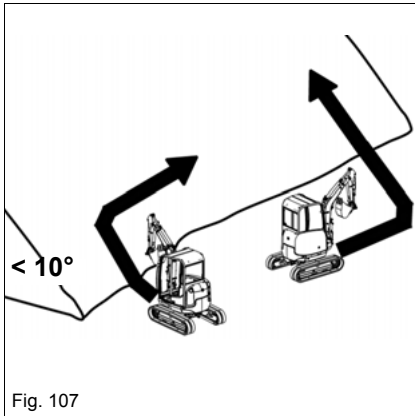
On soft ground, the machine sinks into it or the tracks dig into it. This increases the machine angle (maximum gradient angle and maximum lateral angle of inclination), and the machine can tip over.

If the engine dies as you perform uphill or downhill machine travel, immediately put the control levers to neutral position and restart the engine.

Observe under all circumstances during uphill or downhill travel:

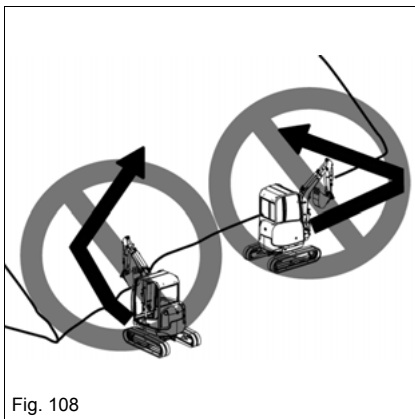
- Keep the drive levers near the neutral position.
- Perform slow and smooth travel movements.
- Avoid sudden travel movements.
- Reduce the engine speed.

The machine can slip even on gentle slopes if it travels across grass, leaves, humid metal surfaces, frozen ground or ice.

**Preparations for performing machine travel on slopes**

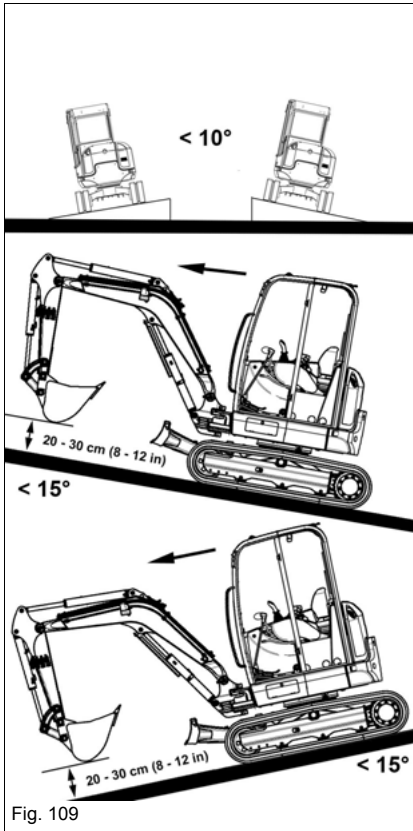
Always perform uphill or downhill machine travel in a straight line.

When changing position, do not exceed a maximum gradient angle of 15° and a maximum lateral angle of inclination of 10°.



Change position on level ground and then perform straight-ahead machine travel onto the slope.



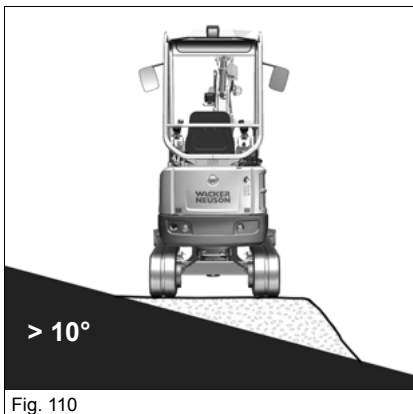


### Uphill machine operation

- Raise the boom 20 – 30 cm (8 – 12 in) off the ground and position it straight ahead at the center of the machine.
- Do not perform machine travel on slopes steeper than 15°.
- Do not perform machine travel on slopes with a lateral angle of inclination over 10°.

### Downhill machine operation

- Raise the boom 20 – 30 cm (8 – 12 in) off the ground and position it straight ahead at the center of the machine.
- In order to minimize the risk of tipping over, adapt the travel speed to the circumstances.
- Do not perform machine travel on slopes steeper than 15°.
- Do not perform machine travel on slopes with a lateral angle of inclination over 10°.



On lateral inclinations over 10°, pile up material to create a horizontal, firm and level standing surface for the machine.

## Parking the machine

### **WARNING**

**Crushing hazard due to machine rolling away under its own weight after parking it!**

Serious injury or death can be caused by not securing the machine.

- ▶ Lower the boom and the stabilizer blade to the ground.
- ▶ Secure the machine accordingly (for example with chocks).

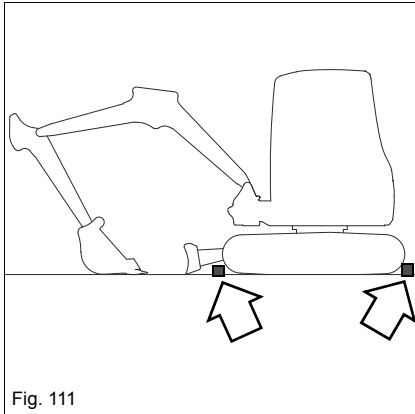


Fig. 111

1. Park the vehicle on firm, level, and horizontal ground.
2. Position the boom straight ahead at the center of the machine.
3. Lower the boom and the stabilizer blade to the ground.
4. Stop the engine.
5. Operate the control lever repeatedly to release the pressure in the hydraulic system.
6. Remove the starting key and carry it with you.
7. Raise the control lever base.
8. Close and lock all covers.
9. Secure the tracks accordingly (for example with chocks, blocks) as shown in *Fig. 111*.

### **Information**

In order to prevent the formation of condensation water, fill up the fuel tank nearly completely at the end of each working day.

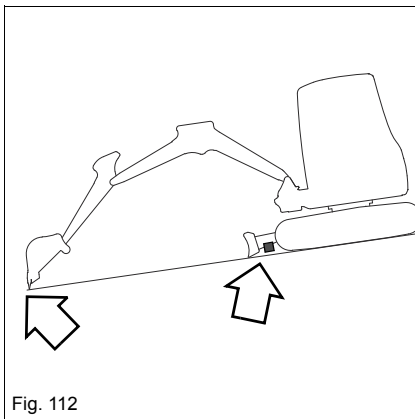


Fig. 112

### **Parking the machine on slopes**

If parking the machine on a slope cannot be avoided, observe the following in addition:

- Position the boom on the downhill side of the machine and firmly press the attachment into the ground.
- Place stabilizer blade on the downhill side.
- Press the stabilizer blade against the ground.
- Secure the machine with wheel chocks (see *Fig. 112*).

## 5.5 Differential lock

Not available.

## 5.6 Lights/signalling system

### **WARNING**

#### Accident hazard due to blinded motorists!

Working lights can blind motorists. This can cause serious injury or death.

- ▶ Stop machine operation if motorists are blinded.
- ▶ Take up operation again only when sufficient illumination of the working area is ensured without blinding motorists.

### Working lights

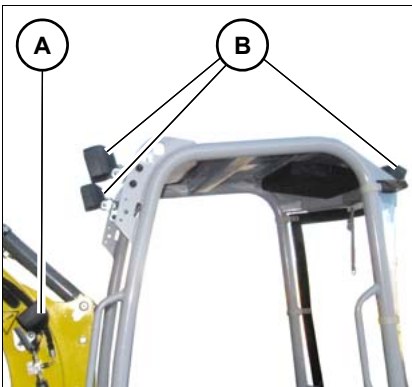


Fig. 113 (symbolic representation)

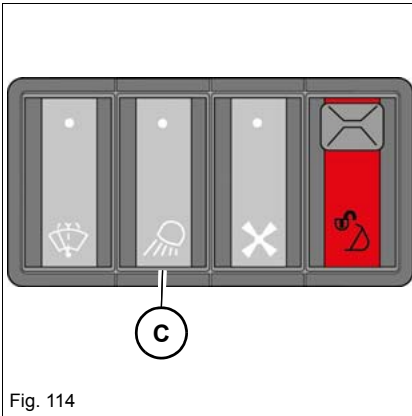


Fig. 114

Position	Designation
<b>A</b>	Boom light
<b>B</b>	Front and rear roof lights (option)

### **Information**

With the **roof-mounted spotlight** option, all work lights are switched on and off together.

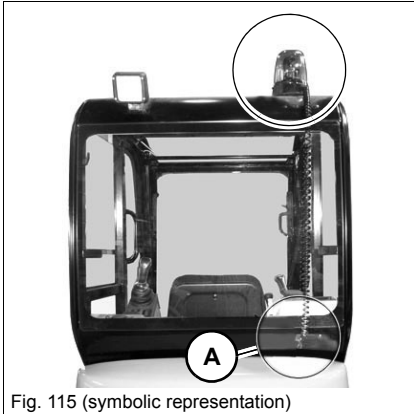
The switch is located on the switch panel.

Working lights	Operation
On	Press the switch <b>C</b> down
Off	Press the switch <b>C</b> up

### **Information**

Switch on the working lights in conditions of poor visibility. If illumination still is not sufficient, use external lights. If this is yet not enough to illuminate the job site sufficiently, stop machine operation and only start it again when sufficient illumination can be ensured.

### Rotating beacon (option)



The rotating beacon has a magnetic base and is attached to the cabin roof. The electric power supply occurs via the 12 volt plug receptacle **A**.

---

**i** **Information**

Observe the national and regional regulations.

---

**i** **Information**

With the attached FOPS screen category II, no rotating beacon can be attached.

---

### Horn



Press touch control **A** on the right-hand control lever to actuate the horn.

## Travel signal (option)

A travel signal sounds as soon as at least one of the tracks moves.

---

### **DANGER**

#### **Accident hazard during forward/backward machine operation!**

Danger of crushing that may lead to serious injuries or death.

- ▶ Do not allow anyone to stay in the danger zone.
  - ▶ Despite the traveling signal the danger zone must also be monitored visually.
  - ▶ If the travel signal does not sound, stop machine operation immediately and contact a Wacker Neuson service center. Follow the relevant national and regional regulations.
-

### 5.7 Wiper/wash system

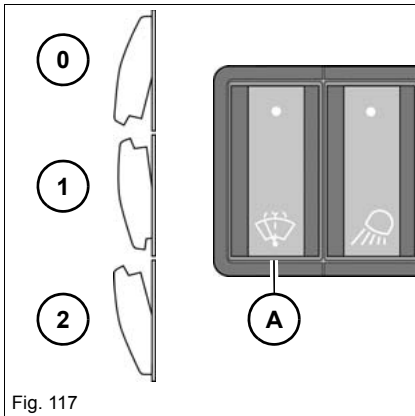


Fig. 117

The switch is located on the switch panel.

Wiper/wash system	Operation
Wipers on	Press switch <b>A</b> into position <b>1</b>
Wipers off	Press switch <b>A</b> into position <b>0</b>
Spraying on	Press switch <b>A</b> into position <b>2</b> and hold
Spraying off	Release switch <b>A</b>

### 5.8 Heating and ventilation

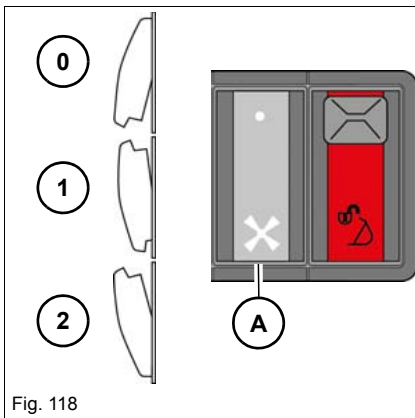


Fig. 118

The switch is located on the switch panel.

Ventilation	Operation
1st range	Press switch <b>A</b> into position <b>1</b>
2nd range	Press switch <b>A</b> into position <b>2</b>
Off	Press switch <b>A</b> into position <b>0</b>

**i** **Information**

If the front windshield is foggy, open the ventilation nozzles fully, direct them forward and place the ventilation on stage 2.

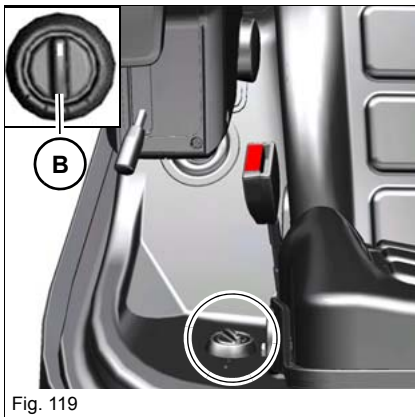






























Fig. 119

The temperature regulator is located on the left next to the operator's seat.

Temperature	Operation
Higher	Turn the rotary control <b>B</b> counterclockwise
Lower	Turn the rotary control <b>B</b> clockwise

## 5.9 Work hydraulics

### Basic control lever functions (ISO and SAE controls)

Control mode	Required function	ISO controls		SAE controls	
		Control levers <sup>1</sup>		Control lever <sup>1</sup>	
		Left	Right	Left	Right
					
	Rotating the upper carriage to the left		--		--
	Rotating the upper carriage to the right		--		--
	Extend stick		--	--	
	Retract the stick		--	--	
	Lower the boom	--			--
	Raise the boom	--			--
	Tilt in the bucket	--		--	
	Tilt out the bucket	--		--	

1. The control levers shown are symbolic representations.

## Rotating the upper carriage

### **WARNING**

#### **Crushing hazard due to rotating range of machine!**

Persons in the rotation range of the machine can be seriously injured or killed.

- ▶ Do not allow anyone to stay in the danger zone.

### **NOTICE**

Possible damage to machine when working in the immediate vicinity of walls, parts of buildings or other obstacles.

- ▶ Ensure that there are no obstacles in the danger zone.

### **Information**

As long as the hydraulic fluid has not reached its operating temperature, the upper carriage can continue moving after releasing the control lever. Operate the control lever carefully in a cold operating state.

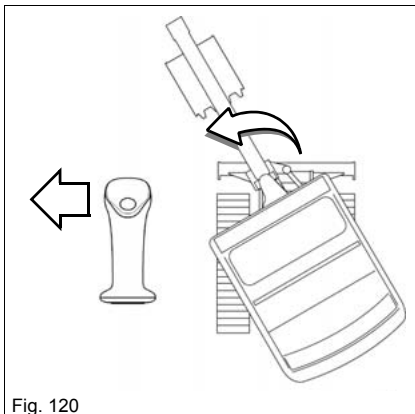


Fig. 120

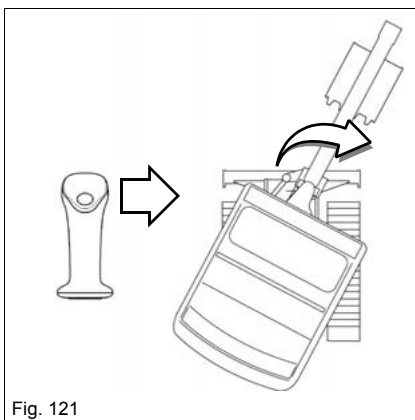


Fig. 121

Rotating the upper carriage	Position
To the left	Push the control lever on the left to the left
To the right	Push the control lever on the left to the right



**Hydraulic swivel unit brake:**

Normal braking: release the control lever.

Maximum braking: press the control lever in the opposite direction until the upper carriage is at a standstill.

**ISO/SAE controls (option)**

The standard equipment of the machine includes ISO controls. SAE controls are available as an option. This results in a different control lever operation.


**WARNING**
**Accident hazard due to modified control mode!**

Modified controls can cause incorrect operation, and serious injury or death.

- ▶ Before starting work, check the selected control type.
- ▶ Always secure the wing nut on the reversing valve.
- ▶ Do not operate the machine with a defective wing nut. Contact a Wacker Neuson service center.

The reversing valve is located on the left in the floor plate **C**.

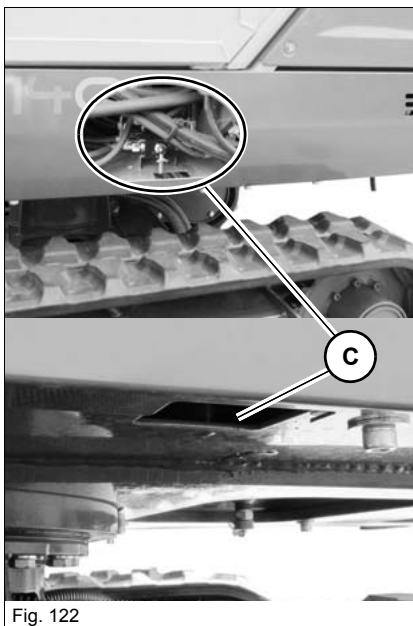


Fig. 122

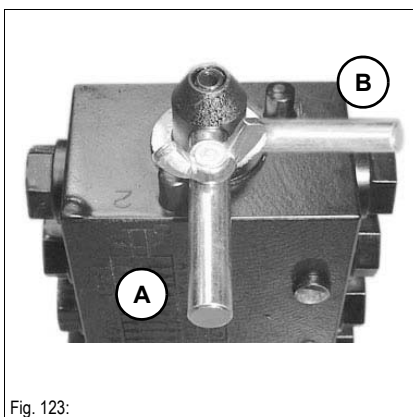


Fig. 123:

Position	Controls
A	ISO controls
B	SAE controls

### Stabilizer blade

---

 **WARNING****Crushing hazard due to unintentional actuation!**

Unintentional actuation can cause serious injury or death.

- ▶ Raise the control lever base.
  - ▶ Lower the stabilizer blade to the ground after the work shift.
  - ▶ Do not allow anyone to stay in the danger zone.
- 

**NOTICE**

Lowering the stabilizer blade too deeply into the ground can create increased resistance.

- ▶ Slightly raise the stabilizer blade. The clearance between the stabilizer blade and the ground should be about 1 cm (0.4 in).
  - ▶ Check the stabilizer-blade position before performing machine travel.
- 

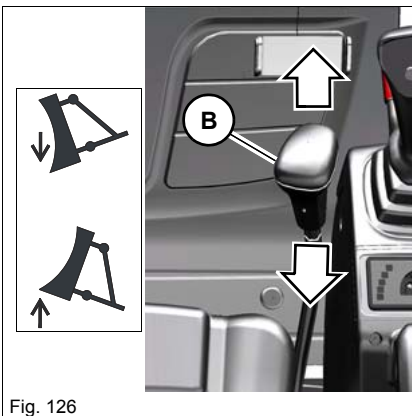
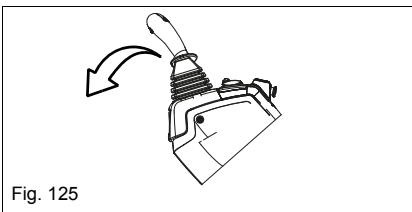
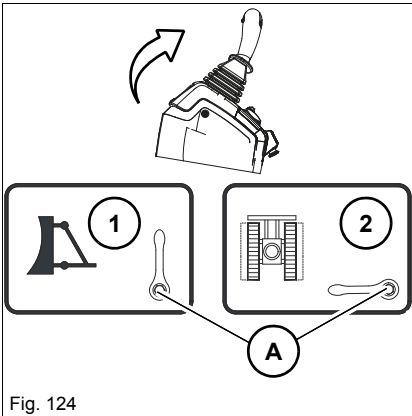
 **Information**

In order to achieve the best possible stability, lower the stabilizer blade.

---

The stabilizer blade is also used as a parking brake. Press the stabilizer blade against the ground.

Position	Function
1	The dozer blade is actuated.
2	The telescopic travel gear is actuated.



1. Raise the control lever base.
2. Make sure that the lever **A** located to the left under the operator's seat is in position **1**.

3. Lower the control lever base.

4. Set the dozer blade to the desired position:

Function	Position
Raise stabilizer blade	Pull lever <b>B</b> backward
Lower stabilizer blade	Push lever <b>B</b> forwards

**i** **Information**

In order to ensure maximum stability during work:

- ▶ Only perform work with an extended telescopic travel gear.
- ▶ Lower the stabilizer blade and turn out the extensions.

### Changing the width of the stabilizer blade

#### **NOTICE**

Damage to machine when travelling through passages.

► The dozer blade and telescopic travel gear must have the same width.

#### **Reducing the width of the stabilizer blade**

1. Raise the dozer blade a little.
2. Shut off the engine and store the ignition switch key safely.
3. Pull out the bolts **A** left and right.

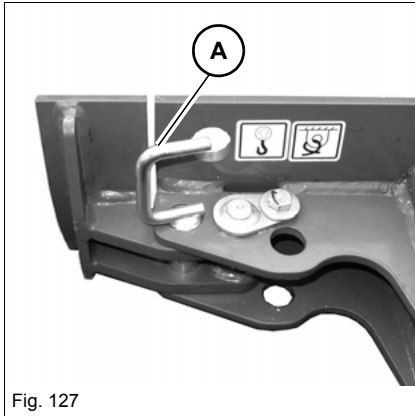


Fig. 127

4. Screw in the dozer blade preparation **B** left and right.
5. Insert the bolts **A** left and right.

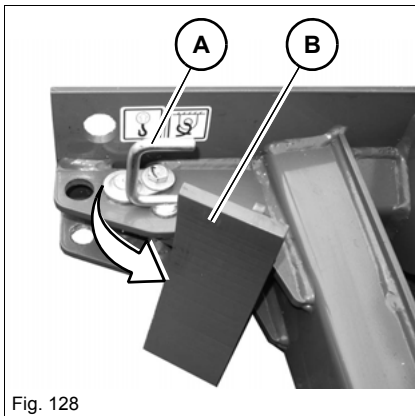
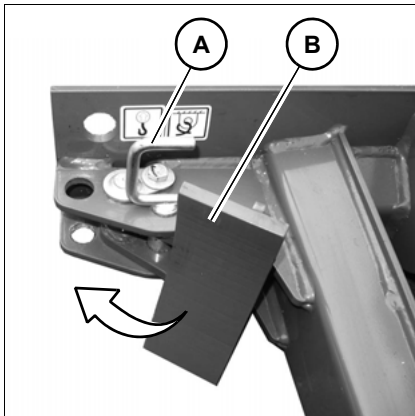


Fig. 128

#### **Increasing the width of the stabilizer blade**

1. Start the engine.
2. Raise the dozer blade a little.
3. Pull out the bolts **A** left and right.
4. Fold out the dozer blade preparation **B** left and right.
5. Insert the bolts **A** left and right.



---

## Telescopic travel gear

---

### **WARNING**

#### **Crushing hazard due to tipping over of machine!**

A tipping machine can cause serious injury or death.

- ▶ Only perform work with an extended telescopic travel gear.
  - ▶ Performing machine travel with a retracted telescopic travel gear is only allowed for machine travel over very short distances through passages. Pay attention to the reduced stability.
  - ▶ Raise the boom about 20 – 30 cm (8 – 12 in) off the ground and position it straight ahead at the center of the machine.  
If a hose bursts on the telescopic cylinder, lower the boom immediately to prevent the machine from tipping over.
  - ▶ Extend and retract the travel gear only on horizontal, level and firm ground.
  - ▶ Retract or extend the telescopic travel gear completely.
- 

### **WARNING**

#### **Danger of crushing when retracting the telescopic travel gear!**

Retracting and extending the telescopic travel gear can cause serious crushing of body parts and death.

- ▶ Do not allow anyone to stay in the danger zone.
  - ▶ Retract or extend the telescopic travel gear completely.
- 

### **NOTICE**

Damage to machine when travelling through passages.

- ▶ The dozer blade and telescopic travel gear must have the same width.
-

Position	Function
1	The dozer blade is actuated.
2	The telescopic travel gear is actuated.

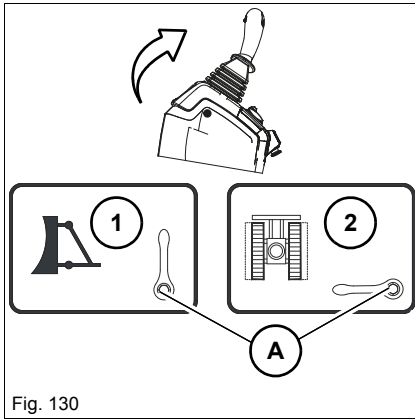


Fig. 130

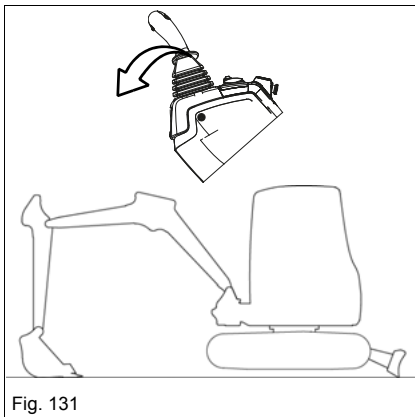


Fig. 131

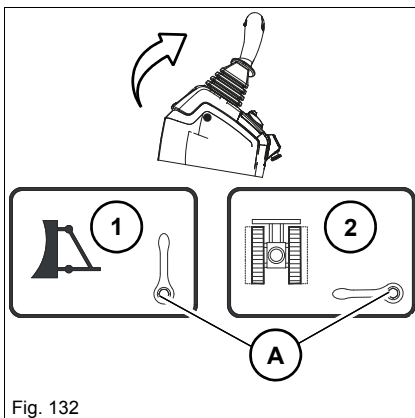


Fig. 132

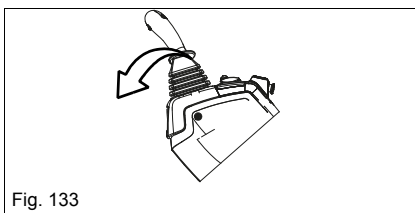


Fig. 133

1. Raise the control lever base.
2. Make sure that the lever **A** located to the left under the operator's seat is in position 1.

3. Lower the control lever base.
4. Using the boom and dozer blade, raise the vehicle so that it is no longer in contact with the ground and no foreign body is in the travel gear during extension or retraction.

5. Raise the control lever base.
6. Set lever **A** in position 2.

7. Lower the control lever base.

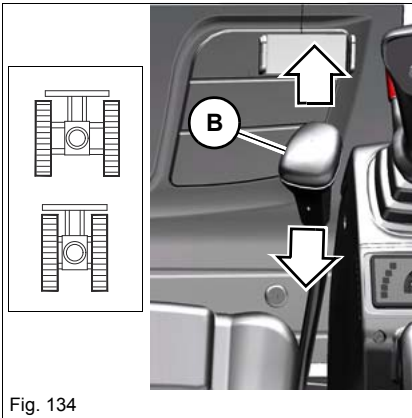


Fig. 134

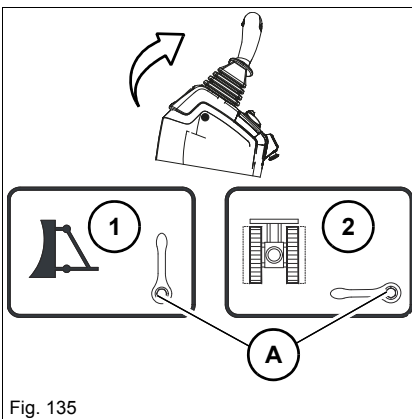


Fig. 135

8. Set the travel gear to the desired position.

Telescopic travel gear	Position
Extend	Push lever <b>B</b> forwards.
Retract	Pull lever <b>B</b> backward

9. Raise the control lever base.

10. Set lever **A** in position 1.

### Information

In order to ensure maximum stability during work:

- ▶ Only perform work with an extended telescopic travel gear.
- ▶ Lower the stabilizer blade and turn out the extensions.

### Hammer operation

Only break in the prescribed work area with shatter protection.

– see chapter “*Shatter protection (option)*” on page 4-20

The machine is not certified for demolition work according to EN 474-5.

A front guard cannot be attached.

---

#### **WARNING**

##### **Danger of piercing/penetration by objects from the front!**

Work involving risk of piercing/penetrating by objects from the front can cause accidents with serious injury or death.

- ▶ During operation, all persons must stay clear of the job site of the machine.
- ▶ Observe the mandatory limits of the work area.
- ▶ Do not hammer horizontally or upward.
- ▶ Only break with the attached shatter protection.

---

#### **WARNING**

##### **Accident hazard due to tipping over of machine!**

A tipping machine can cause serious injury or death.

- ▶ During operation, all persons must stay clear of the job site of the machine.
- ▶ The machine can lose its balance and tip over if a hammer or other heavy attachment is used.
- ▶ Never turn, lower or set down the attachment abruptly.
- ▶ Do not extend or retract the boom abruptly.
- ▶ Do not use the impact force of the attachment to perform demolition work. Broken or falling pieces can cause serious injury.
- ▶ Use a hammer only at machine standstill.

---

#### **Information**

In combination with Powertilt, only use the smallest possible released hydraulic breaker.

---

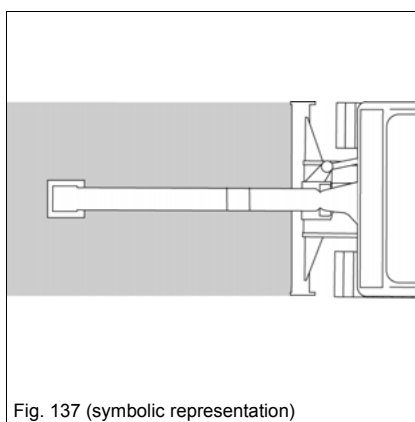
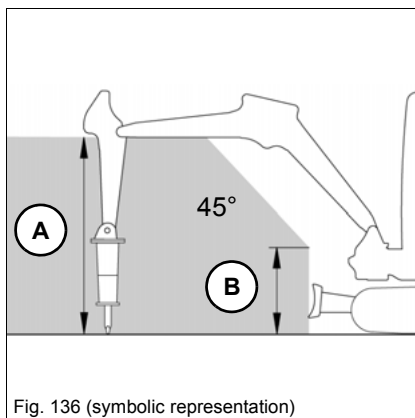


## Working with a hydraulic hammer

### NOTICE

In order to avoid damage to the machine or hydraulic hammer, observe the following points:

- ▶ Observe the Operator's Manual of the hydraulic hammer.
- ▶ Do not hammer horizontally or upward.
- ▶ Do not use the hammer to raise loads.
- ▶ Do not hit the hammer against rocks, concrete, etc..
- ▶ Do not hammer in the same spot uninterruptedly for more than 15 seconds.
- ▶ Do not raise the machine with the boom.
- ▶ Do not work with fully extended cylinders or arm system. Do not pivot the Powertilt unit beyond 30° during breaker operation, otherwise the load on the boom increases tremendously.
- ▶ Stop machine operation immediately if a hydraulic hose moves back and forth in an unusual manner. The pressure accumulator could be malfunctioning. Contact a Wacker Neuson service center and have the malfunction rectified immediately.
- ▶ Do not use the impact force of the attachment to perform demolition work. Broken or falling pieces can cause damage to the equipment.



### Job site

Work range height **A**: 120 cm (47 in), **B**: 50 cm (20 in)

Figures 136 and 137 refer to work with a Wacker Neuson hydraulic hammer.

Working with another tool can result in a different work area.

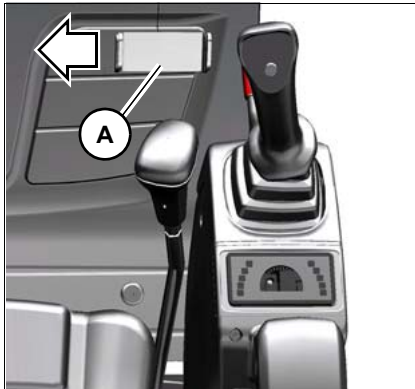


Fig. 138

Hammer operation	Position
Switch on	Actuate the pedal <b>A</b> to the left
Switch off	Release the pedal <b>A</b>

### Additional control circuit – AUX I

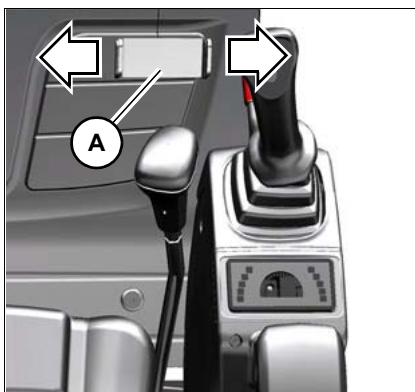


Fig. 139

#### Operating the additional control circuit

Oil flow	Position
To the line on the left	Actuate pedal <b>A</b> to the left
To the line on the right	Actuate pedal <b>A</b> to the right

### Swiveling the boom

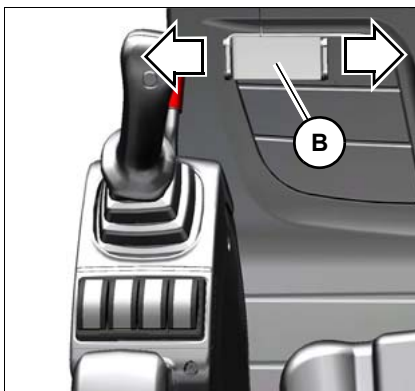


Fig. 140

Boom	Position
Swivel to the left	Actuate pedal <b>B</b> to the left
Swivel to the right	Actuate pedal <b>B</b> to the right

### Lehnhoff mechanical quickhitch system (optional)

- The quick coupler system and the attachment support must be undamaged and clean.
- Store the operator's manual of the mechanical quick coupler system together with the operator's manual of the machine.
- The described operation does not apply to the face shovel. Contact an authorized workshop for face shovel operation.

---

#### **WARNING**

##### **Crushing hazard when picking up attachments!**

If an attachment is not locked correctly, it can come off and cause serious injury or death.

- ▶ Do not allow anyone to stay in the danger zone.
- ▶ During locking and unlocking procedures, make sure that hands and feet are not crushed.
- ▶ Only use undamaged attachments and quick coupler systems.
- ▶ Before starting any work and after every locking process, press the attachment to the ground and quickly move it back and forth over just over the ground a few times to check the secure locking.
- ▶ Only operate the machine with a safely locked attachment.

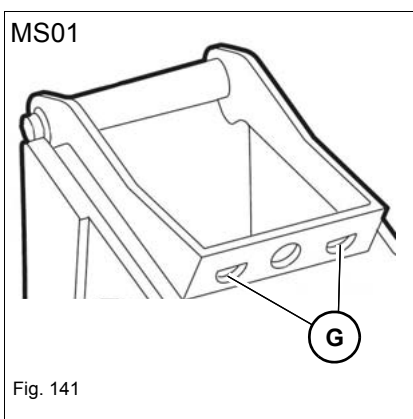
---

#### **WARNING**

##### **Crushing hazard when attachments are removed!**

If an attachment is not removed correctly, it can tip over and cause serious injury or death.

- ▶ Do not allow anyone to stay in the danger zone.
- ▶ Lower the attachment to level and firm ground ensuring stability.



#### **Support**

ET16: Support for MS01

**G:** Openings for quick coupler system bolts

### Picking up an attachment

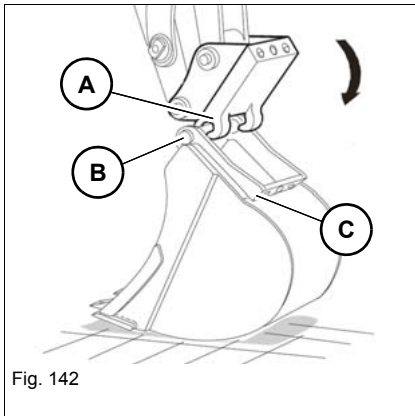


Fig. 142

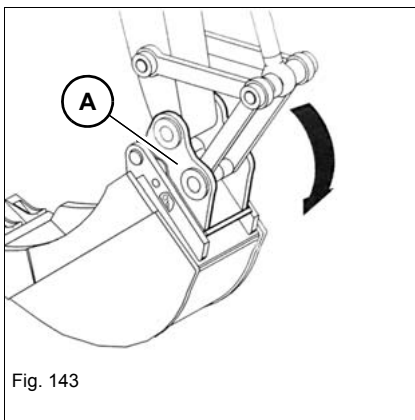
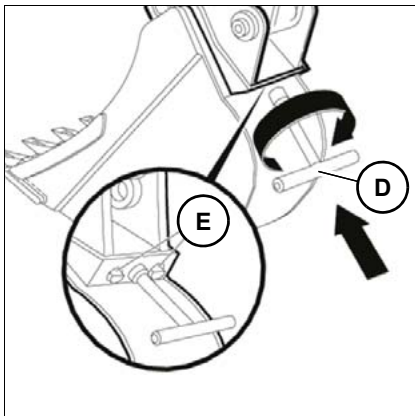


Fig. 143



1. Hook up the quick coupler system **A** in the attachment bolt **B**.
2. Slightly screw in the quick coupler system **A**, lift the shovel arm until the attachment is suspended about 30 cm (12 in) above the ground.
3. Extend the bucket cylinder so that the edge **C** of the attachment touches the quick coupler system.

4. Screw in the quick coupler system **A** until the attachment lies completely on the quick coupler system **A** due to its weight.
5. Shut off the engine and store the ignition switch key safely.

6. Screw socket wrench **D** clockwise until the bolts **E** completely engage in the openings **G** of the quick coupler system **A**.
  - The quick coupler system is locked.
7. Remove the socket wrench and perform a visual inspection.
8. Start the engine.

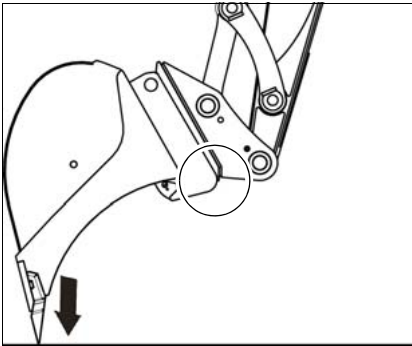


Fig. 145

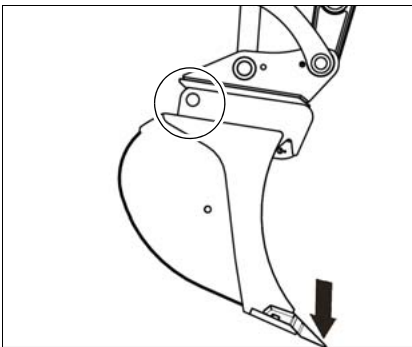


Fig. 146

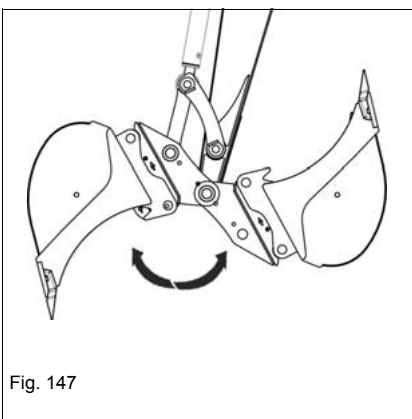


Fig. 147

9. Before starting any work and after every locking process, press the attachment to the ground and quickly move it back and forth over just over the ground a few times.
- ➔ The attachment may not detach from the quick coupler system in the process.

### Setting down an attachment

1. Screw in the attachment and position it at 5 – 10 cm (2 – 4 in) above the ground.
2. Shut off the engine and store the ignition switch key safely.

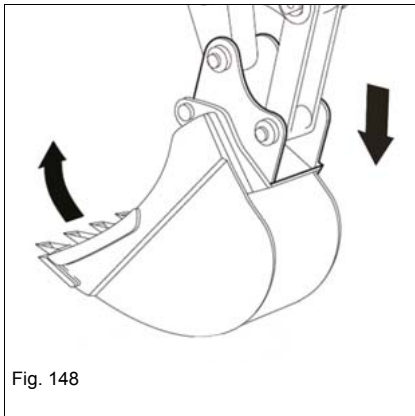


Fig. 148

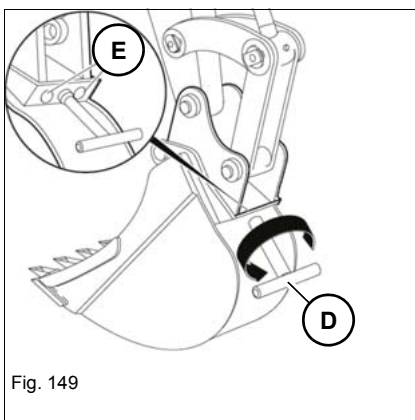


Fig. 149

3. Turn the socket wrench **D** counter-clockwise until the bolts **E** are completely retracted.
  - The quick coupler system is unlocked.
4. Remove the socket wrench.
5. Start the engine.
6. Lower the attachment to level and firm ground ensuring stability.

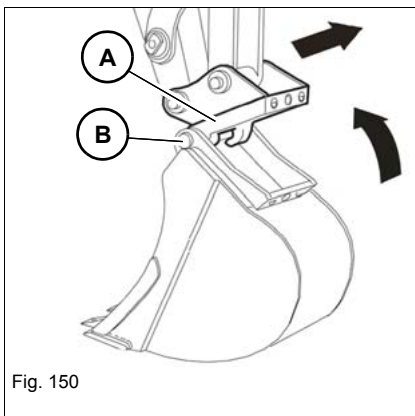


Fig. 150

7. Retract the bucket cylinder and quick coupler system **A** from the attachment bolt **B**.

## **Preparation for hydraulic quickhitch (option)**

The HSWS preparation is a hydraulic auxiliary control circuit attached to the vehicle boom that was designed, developed and released for the hydraulic quick coupler systems described in this operator's manual.

Wacker Neuson is not liable for injuries or damage if at least one of the following items is not complied with:

- Follow the operator's manual for the hydraulic quickhitch.
- Store the Operator's Manual of the hydraulic quickhitch together with the Operator's Manual of the machine.
- For non-released quickhitch systems, there may be differences in the operating functions or the operation of the vehicle - Observe the operator's manual of the quickhitch system or the attachment.

Nevertheless, should a non-released HSWS be used, the following points must also be observed:

- If required, modifications on the machine (for example additional adhesive labels) or the operator's manual of the machine (if operation is different) must be made.
- The intended purpose of the machine may be restricted.
- Assembling a hydraulic quick coupler system that does not fit with the vehicle or its interface (e.g. pressure settings) may void the declaration of conformity of the vehicle. Contact a Wacker Neuson service center.
- Assembling a hydraulic quick coupler system to a vehicle that does not fit with the vehicle or its interface (e.g. pressure settings) may void the declaration of conformity of the hydraulic quick coupler. Contact a Wacker Neuson service center.

### Hydraulic Easy Lock quickhitch (option)

- Attend specific training before putting into operation. Training must be given by authorized technical personnel and must be understood by the operator.
- For safety reasons, the quickhitch must be operated with two control elements. This avoids opening the quickhitch unintentionally during work operation.
- The quick coupler system and the attachment support must be undamaged and clean.
- For more information, see **Easy Lock/Powertilt with Easy Lock** Operator's Manual.
- Store the **Easy Lock/Powertilt with Easy Lock** operator's manual together with the vehicle's operator's manual.



#### **WARNING**

##### **Crushing hazard when picking up attachments!**

If an attachment is not locked correctly, it can come off and cause serious injury or death.

- ▶ Do not allow anyone to stay in the danger zone.
- ▶ Only use undamaged attachments and quick coupler systems.
- ▶ Check pin **F** must be fully retracted. Otherwise repeat the lock cycle until check pin **F** is retracted.
- ▶ Before starting any work and after every locking process, press the attachment to the ground and quickly move it back and forth over just over the ground a few times to check the secure locking.
- ▶ Operate the machine only with a safely locked attachment.



#### **WARNING**

##### **Danger of crushing when attachments are removed!**

If an attachment is not locked correctly, it can tip over and cause serious injury or death.

- ▶ Do not allow anyone to stay in the danger zone.
- ▶ Lower the attachment to level and firm ground ensuring stability.




**WARNING**

**Danger of crushing due to incorrect operation of the hydraulic quickhitch system!**

For system-specific reasons, the quickhitch can also be operated with other hydraulic functions. This can cause serious injury or death.

- ▶ Operate the hydraulic quickhitch only with the function **Raise stabilizer blade**.

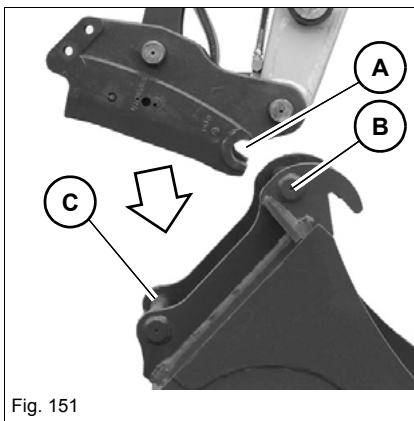
**Picking up an attachment**


Fig. 151

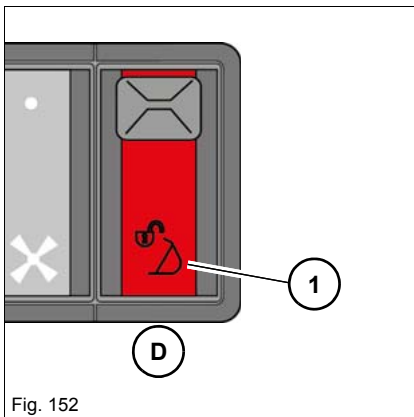


Fig. 152

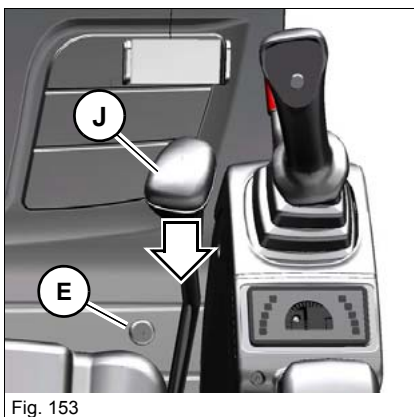


Fig. 153

1. Hook up the quick coupler system **A** in the bolts **B** of the attachment receptacle.
2. Extend the bucket cylinder so that pin **C** of the attachment touches the quickhitch.
3. Check whether the attachment touches the quick coupler system with the bolt **C**.
4. Move the attachment inward completely.
5. Unlock switch **D** and press it to position **1**.
  - ➔ The quickhitch is enabled and the buzzer sounds.
6. Press and hold the foot-operated touch button **E** and at the same time pull back the **J** dozer blade lever.
  - ➔ The quickhitch opens.

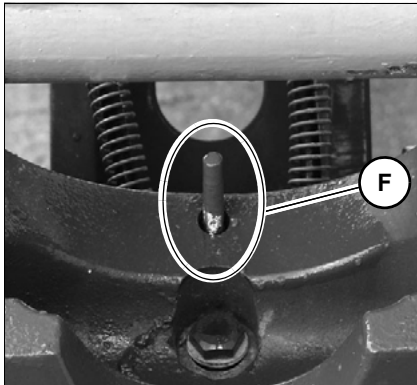


Fig. 154

- Check pin **F** must be fully extended.
- The attachment engages.

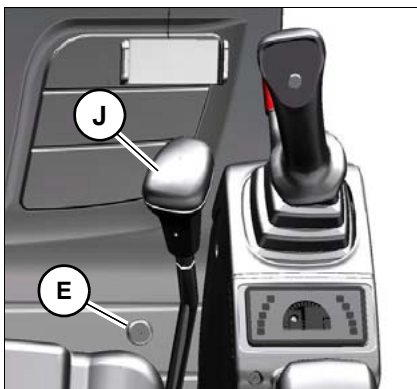


Fig. 155

7. Release the dozer blade lever **J** and foot-operated touch button **E** .
  - The quickhitch closes.

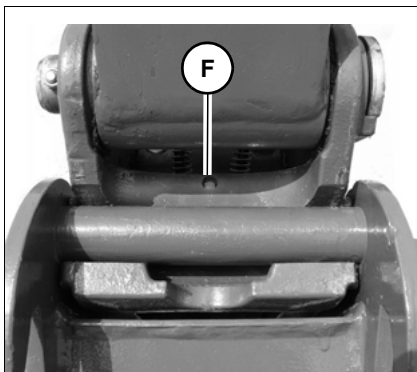


Fig. 156

- Check pin **F** must be fully retracted.

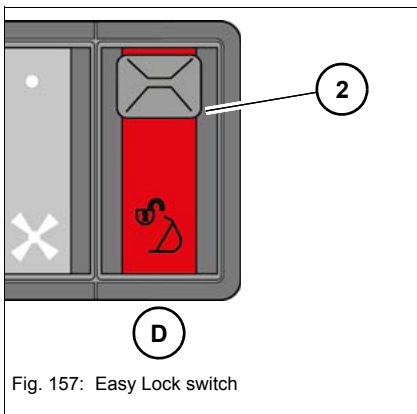


Fig. 157: Easy Lock switch

8. Press switch **D** to position **2**.
  - The quickhitch is disabled and the buzzer does not sound any longer.

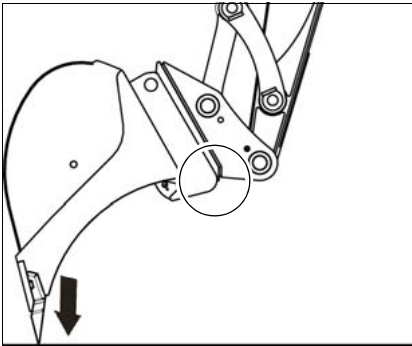


Fig. 158

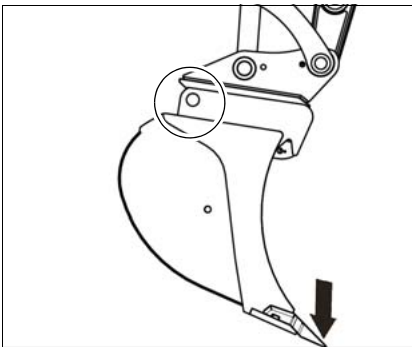


Fig. 159

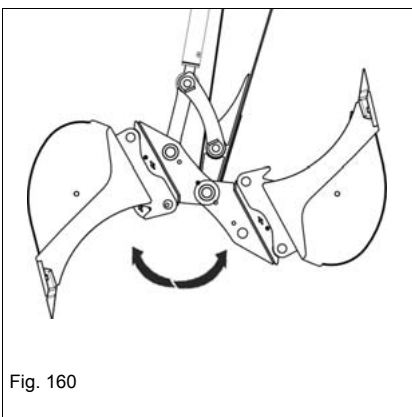


Fig. 160

9. Before starting any work and after every locking process, press the attachment to the ground and quickly move it back and forth over just over the ground a few times to check the secure locking.
- The attachment may not detach from the quick coupler system in the process.

### Manual HSWS bolt lock

Depending on national provisions, the HSWS must also be manually locked according to the hydraulic locking process.

The locking or unlocking is located to the left on the quick coupler system.

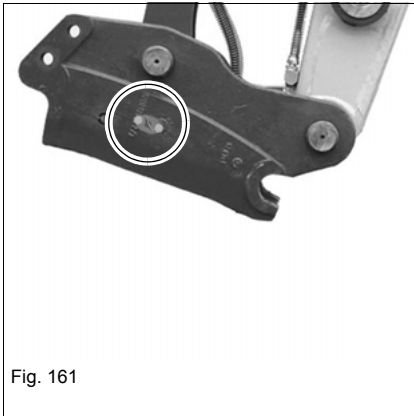


Fig. 161

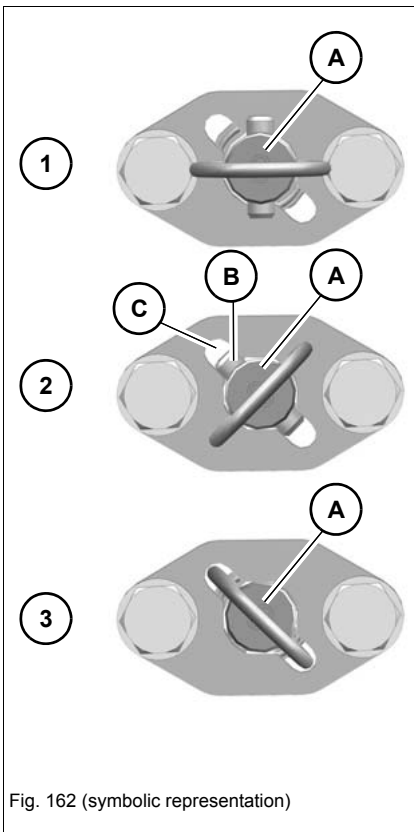


Fig. 162 (symbolic representation)

- Stop the engine and remove the starting key.
- Raise the control lever base.
- Rotate bolt **A** so that the pin **B** fits in the recess **C** (2).
- Press in the bolt **A** and turn until it is held in its position by the spring (3).
  - ➔ The HSWS is also manually locked.

---

#### **i** Information

Comply with national provisions.

---

#### **i** Information

The bolt positions may deviate in their final position from the figures.

---

**Setting down an attachment**

**Manual HSWS bolt unlocking**

Depending on national provisions, the HSWS must also be manually unlocked according to the hydraulic unlocking process.

The locking or unlocking is located to the left on the quick coupler system.

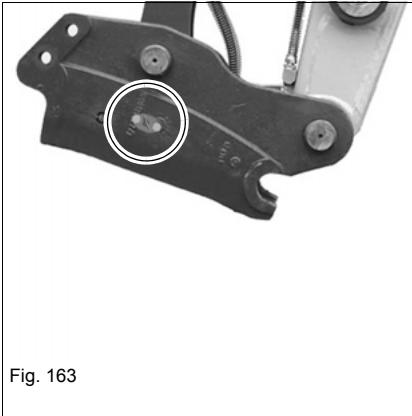


Fig. 163

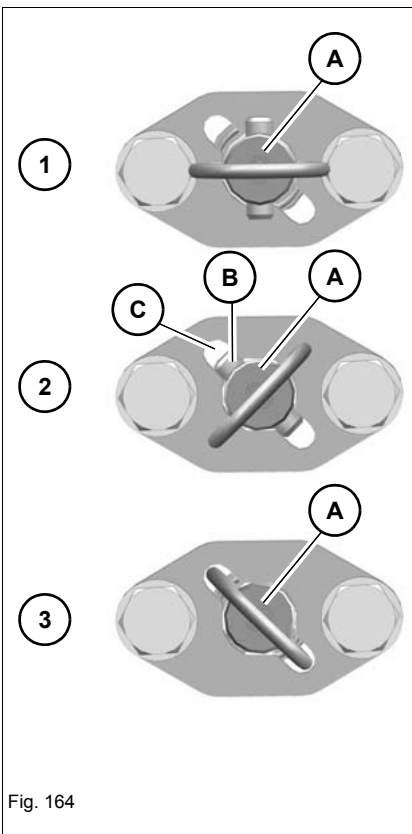


Fig. 164

- Stop the engine and remove the starting key.
- Raise the control lever base.
- Rotate bolt **A** so that the pin **B** fits in the recess **C** (2).
- Pull out the bolt **A** (1).
  - ➔ The HSWS is manually unlocked. The attachment is still hydraulically locked.

---

**i Information**  
Comply with national provisions.

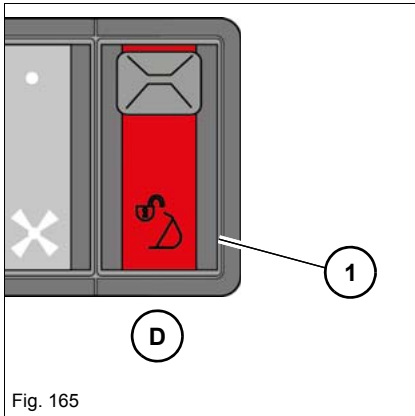
---



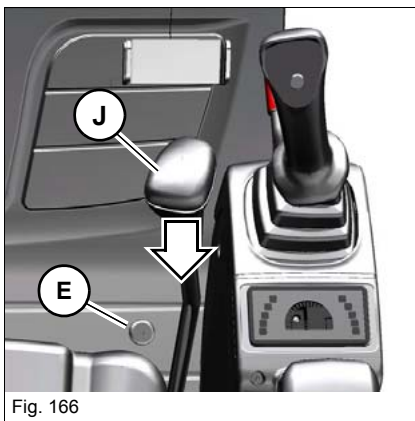
---

**i Information**  
The bolt positions may deviate in their final position from the figures.

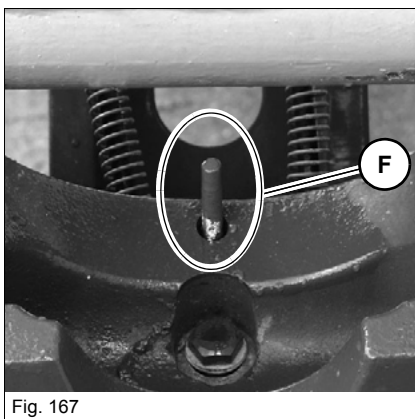
---



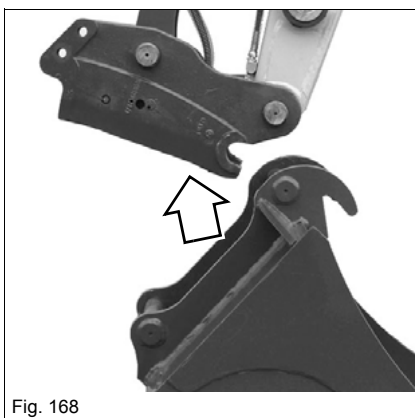
1. Move the attachment inward completely and position it at 5–10 cm (2–4 in) above the ground.
2. Unlock switch **D** and press it to position **1**.
  - The quickhitch is enabled and the buzzer sounds.



3. Press and hold the foot-operated touch button **E** and at the same time pull back the **J** dozer blade lever.
  - The quickhitch opens.



- Check pin **F** must be fully extended.



4. Retract the bucket cylinder.
  - The attachment is lowered to the ground.

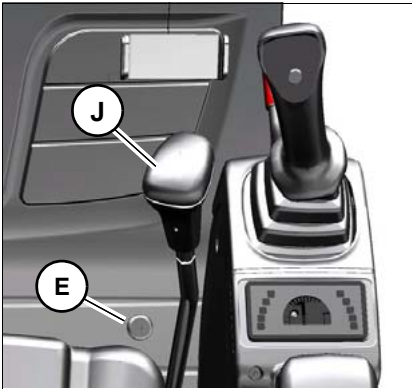


Fig. 169

5. Release the dozer blade lever **J** and foot-operated touch button **E**.
  - ➔ The quickhitch closes.

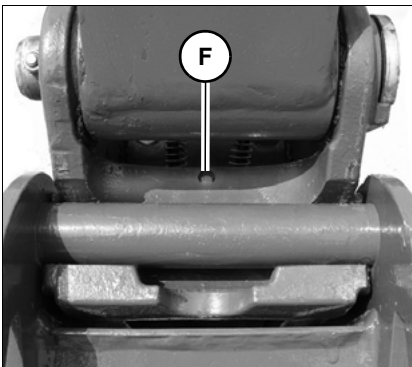


Fig. 170:

- ➔ Check pin **F** must be fully retracted.

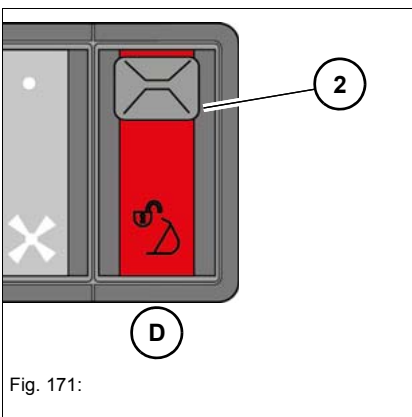


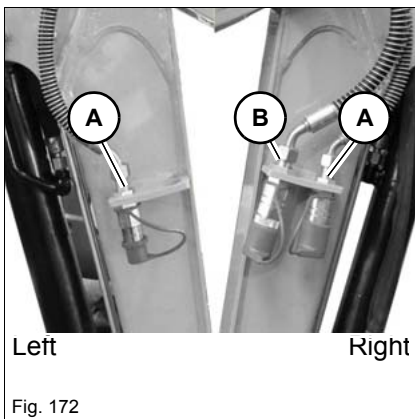
Fig. 171:

6. Press switch **D** to position **2**.
  - ➔ The quickhitch is disabled and the buzzer does not sound any longer.

### Connecting and disconnecting hydraulic couplings

1. Stop and park the machine. See "Preparing lubrication".
  2. Position the boom straight ahead at the center of the machine.
  3. Lower the stabilizer blade to the ground.
  4. Turn the starting key to position 1.
  5. Move the control lever or the slide switch of the hydraulic circuit in all directions repeatedly.
  6. Remove the starting key and carry it with you.
- ➔ The grab hose couplings can now be coupled and uncoupled.

### Hydraulic connections



Connection	Stick (left/right)
A	AUX I
B	Large return line

#### **i** Information

Follow the instructions in the Operator's Manual of the attachment manufacturer for connecting the hydraulics to the attachment.



**Load-retaining function**
 **WARNING**
**Injury hazard due to fluid escaping under pressure!**

Hydraulic oil escaping under pressure can penetrate the skin and cause serious injury or death.

- ▶ Do not allow anyone to stay in the danger zone.
- ▶ If a hose bursts, move the control elements to neutral position so that as little hydraulic oil as possible escapes.

 **WARNING**
**Burn hazard due to hot hydraulic oil!**

Hot hydraulic oil can cause burns to the skin.

- ▶ If a hose bursts, move the control elements to neutral position so that as little hydraulic oil as possible escapes.
- ▶ Wear protective equipment.

 **Information**

Hose burst valves are set at the factory and secured with seals. The correct functioning is no longer ensured and warranty is void if a seal is removed or if the hose burst valve is tampered with.

If a hose bursts, move the control lever or stabilizer blade lever to neutral.

<b>Load-retaining function</b>	<b>Position</b>
Stabilizer blade	Hose burst valve



---

### Proceed as follows after a damage:

1. Stop the machine immediately.
2. Stop the engine.
3. Move the control lever or stabilizer blade lever to neutral.
4. Perform emergency lowering if possible – *see chapter “5.12 Emergency lowering” on page 5-52.*
5. Raise the control lever base.
6. Remove the starting key and lock the cabin.
7. Secure the machine and the attachment.
8. Contact a Wacker Neuson service center and have the malfunction rectified.



### Environment

Use a suitable container to collect fluids and lubricants as they flow out and dispose of them in an environmentally friendly manner.

---

## 5.10 Attachments

### Picking up

---

 **WARNING****Injury hazard due to fluid escaping under pressure!**

Hydraulic oil escaping under pressure can penetrate the skin and cause serious injury or death.

- ▶ Do not allow anyone to stay in the danger zone.
  - ▶ Release the pressure in the hydraulic system before connecting or disconnecting the attachment – *see chapter “Releasing the pressure in the work hydraulics” on page 5-43.*
  - ▶ Wear protective clothes.
  - ▶ Always consult a doctor immediately, even if the wound seems insignificant. Hydraulic oil causes blood poisoning.
- 

 **WARNING****Accident hazard when picking up attachments!**

Picking up attachments incorrectly can cause serious injury or death.

- ▶ Wear protective equipment during installation of the connecting pins.
  - ▶ Do not allow anyone to stay in the danger zone.
  - ▶ Only use attachments that are in perfect condition.
  - ▶ Set and adjust the boom to the correct position with the control levers.
  - ▶ Align the fastening bores in the attachment with a mandrel to make it easier to insert the pin in the bores.
  - ▶ Ensure correct locking with a short and rapid succession of stick and bucket movements as close as possible to the ground.
  - ▶ Operate the machine only with a safely locked attachment
-

---

### Setting down

---

#### **WARNING**

##### **Crushing hazard when attachments are removed!**

If an attachment is not removed correctly, it can tip over and cause serious injury or death.

- ▶ Do not allow anyone to stay in the danger zone.
  - ▶ Lower the attachment to level and firm ground ensuring stability.
  - ▶ Only remove the pins from the attachment if it is in a stable position.
  - ▶ Lower the attachment to the ground without too much pressure, otherwise the resistance is too high when the pins are removed.
- 

Re-equipping the attachments is described below for a bucket.

Follow the special information when fitting or removing attachments with their own hydraulic functions (for example an offset bucket). Observe the Operator's Manual of the attachment.

---

#### **Information**

The hydraulic system of the machine is still pressurized even when the engine is not running. Due to the residual pressure, the hydraulic quick couplers can be removed but not installed back on again.

- ▶ Release the pressure.
-

## Releasing the pressure in the work hydraulics

1. Stop the machine on firm, level, and horizontal ground.
2. Lower the attachment completely to the ground.
3. Lower the stabilizer blade to the ground.
4. Stop the engine.
5. Turn the starting key to position 1.
6. Move the control lever or the slide switch of the proportional controls of the relevant hydraulic circuit in all directions repeatedly.
  - The pressure in the corresponding system sections is released. This can be seen by the brief movement the hoses make as the pressure is released.
  - Uncouple the attachment immediately after the pressure has been released, otherwise pressure can be created again.

## Re-equipping

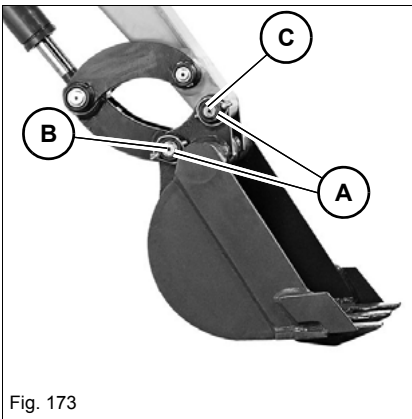


Fig. 173

### Removing

1. Lower the bucket to level ground with the flat side facing downward.
2. Stop and park the machine. Stop the engine. See "Preparing lubrication".
3. Remove lynch pins **A**.
4. First remove pin **B**, and then pin **C**. Carefully expel pins that are stuck with a hammer and a brass punch.

If pin **C** is stuck:

1. Start the engine.
2. Slightly raise and lower the boom to take the load off the pin.
3. Stop and park the machine. Stop the engine. See "Preparing lubrication".
4. Raise the control lever base.
5. Remove the starting key and carry it with you.



### Information

Place the bucket only with minimum pressure on the ground as you remove the pins. The higher the pressure on the ground, the higher the resistance and the more difficult it is to remove the pins.

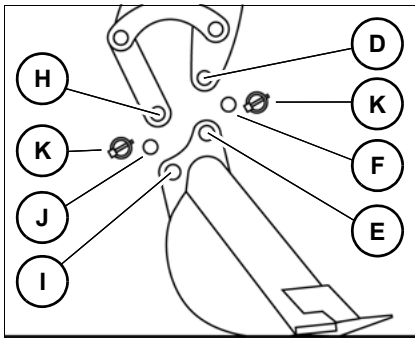


Fig. 174

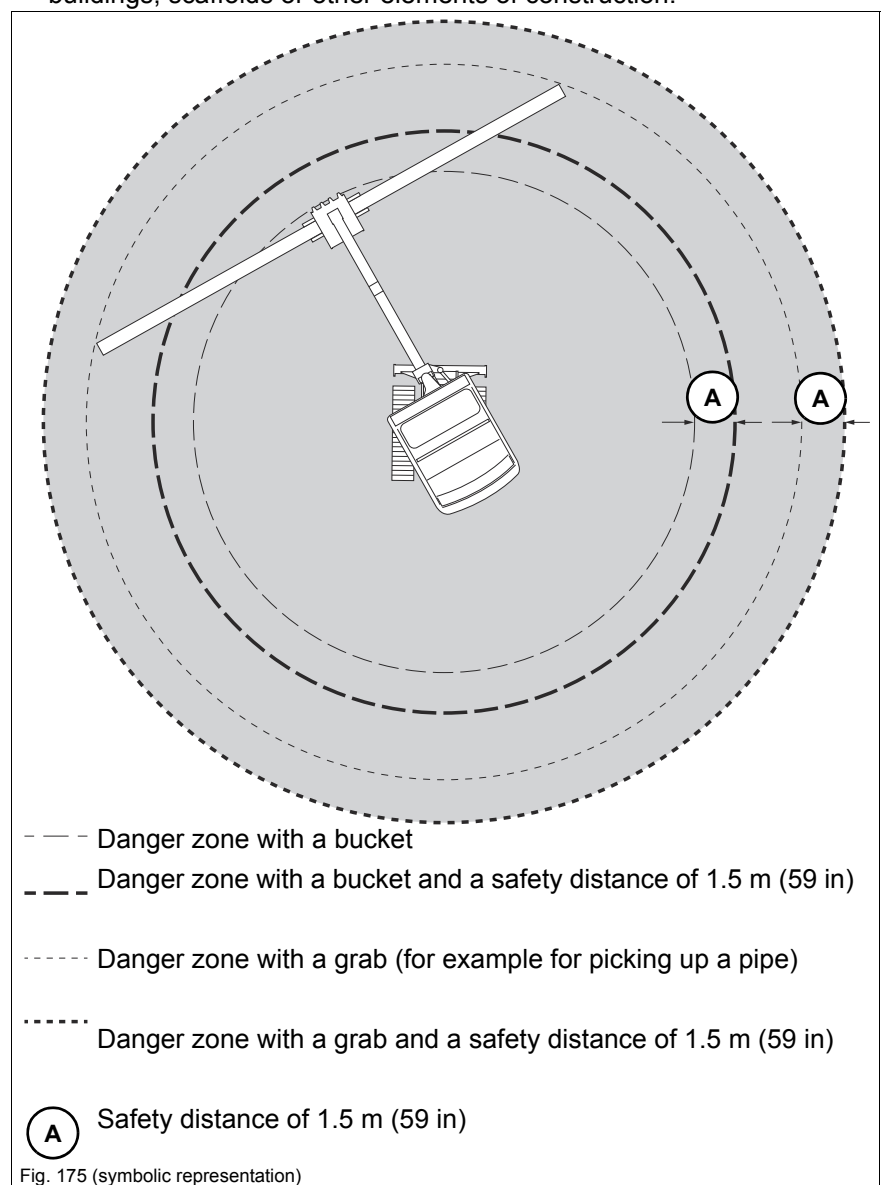
**Mount**

1. Install a bucket only if it is positioned on level ground with the flat side facing downward.
2. Stop and park the machine. Stop the engine. See "Preparing lubrication".
3. Apply grease to the pins and articulations before inserting them.
4. Start the engine.
5. Straighten the stick so that bores **D** and **E** are flush.
6. Stop the engine. Raise the control lever base.
7. Insert pin **F**.
8. Actuate the stick cylinder until bores **H** and **I** are flush.
9. Stop the engine. Raise the control lever base.
10. Insert pin **J**.
11. Install linch pins **K**.

## 5.11 Work operation

### Danger zone

- The danger zone is the area in which persons are in danger due to the movements of the machine, attachment or load.
- The danger zone also includes the area that can be affected by falling material, equipment or by parts that are thrown out.
- The danger zone on a slope is different from the one on a level surface (secure the load). See chapter “**Operation, driving on slopes**”.
- Stop machine operation immediately if persons do not stay clear of the danger zone.
- Seal off the danger zone should it not be possible to keep a sufficient safety distance.
- Extend the danger zone sufficiently in the immediate vicinity of buildings, scaffolds or other elements of construction.



## Inadmissible work procedures

Inadmissible operation can damage the machine or the attachment.

### Working with the swivel force

Do not use the swivel force of the upper carriage to tear down walls or to create level surfaces.

Never ram the attachment into the ground when swiveling the upper carriage.

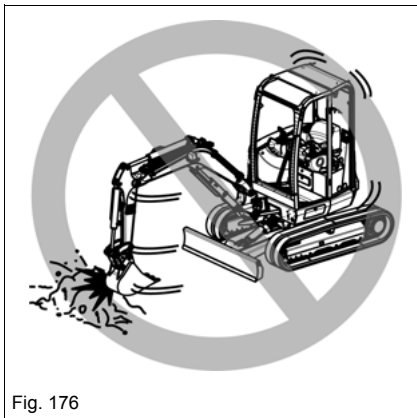


Fig. 176

### Working with the drive force

Do not ram the attachment into ground or lower the boom during machine travel.

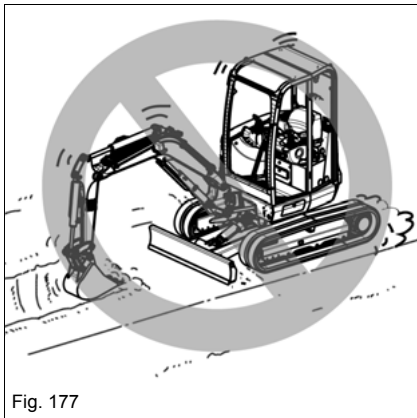


Fig. 177

### Retracting the attachment

When retracting the attachment, ensure that it does not touch the stabilizer blade.

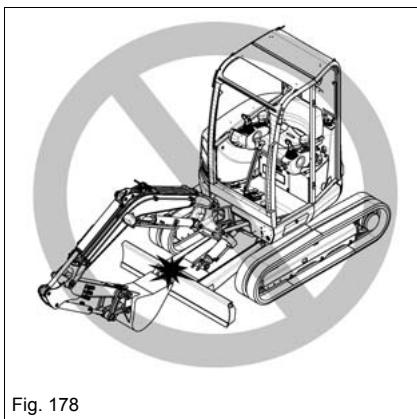


Fig. 178



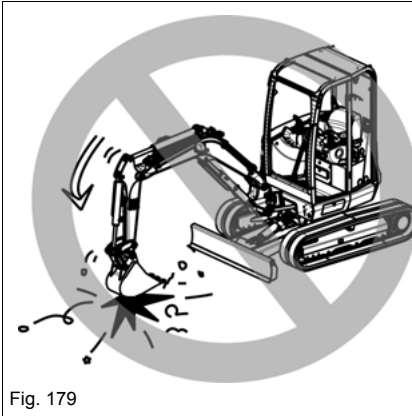


Fig. 179

**Working with the falling force by lowering the attachment**

Do not use the falling force of the attachment as a hoe, hammer or pile-driver.

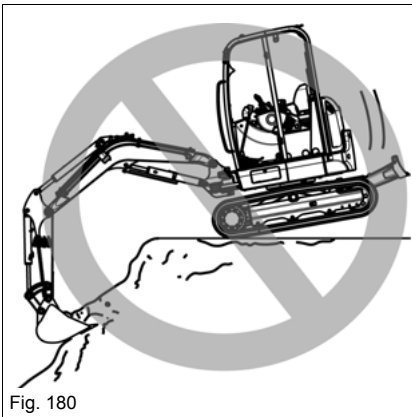


Fig. 180

**Working with the falling force by lowering the machine**

Do not use the dead weight of the machine for work.  
Use the force of the hydraulic cylinders exclusively.

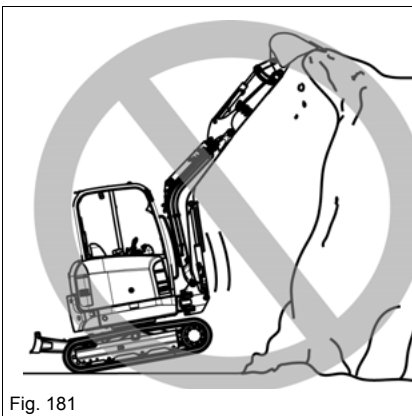


Fig. 181

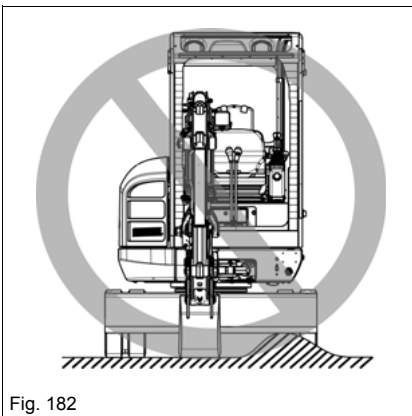


Fig. 182

**Fully lowering the stabilizer blade**

Apply the full weight of the machine over the entire width of the stabilizer blade when using it for stabilization.

**Protecting the stabilizer legs/blade against shocks**

The dozer blade or dozer blade cylinder can be damaged if the dozer blade hits against obstacles.

**General information regarding work operation**

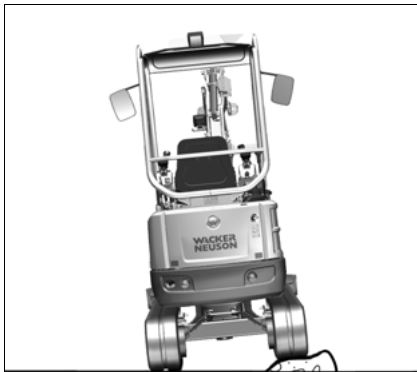


Fig. 183

**Machine travel**

Performing machine travel over obstacles can put a heavy load on the undercarriage and cause damage. Avoid performing machine travel over obstacles if possible.

If it cannot be avoided, lower the boom to ground level and travel over the obstacle at low speed.

**Traveling in speed range 2**

Avoid starting machine travel and stopping abruptly as well as changing direction suddenly on rough terrain.

The dozer blade must be at the front during travel speed 2.

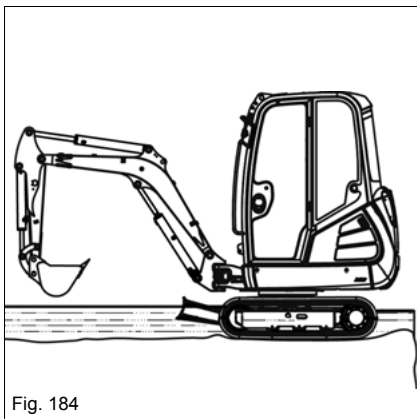


Fig. 184

**Operation in water**

Water must not reach any further than the upper edge of the tensioning wheel.

Lubricate lubrication points again that were immersed in water for a longer time in order to expel the old grease.

Do not immerse the live ring and upper carriage in the water.

Operation in salt water is prohibited.

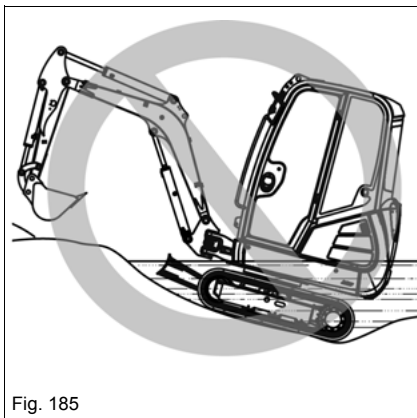


Fig. 185

Do not immerse the live ring and upper carriage in the water.

**Operation near the sea**

Clean the machine regularly when using it in a saline environment.

See chapter **Cleaning and maintenance**.

## Working with the bucket

The following section describes work operations with the machine equipped with a backhoe bucket. The backhoe bucket is mainly used for earth-moving applications (digging, loosening, picking up and loading loose or solid material).

Place the stabilizer blade on the side you want to dig.

### Bucket position when digging

Perform long, level excavation movements with the stick and the bucket. The maximum excavation force is achieved at an angle of 80 to 120° between the boom and the stick.

1. Penetrate into the ground with the bucket.
2. Lower the stick and at the same time, position the bucket so that the flat lower side of the bucket is parallel with the ground.
3. Move the stick toward the machine and tilt in the bucket at the same time.

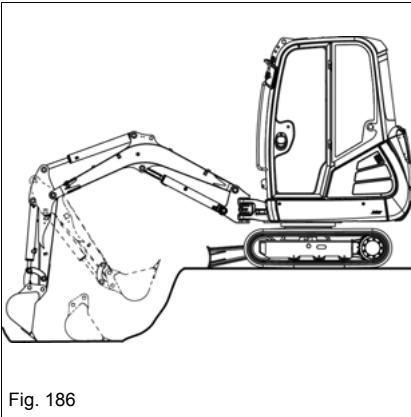


Fig. 186

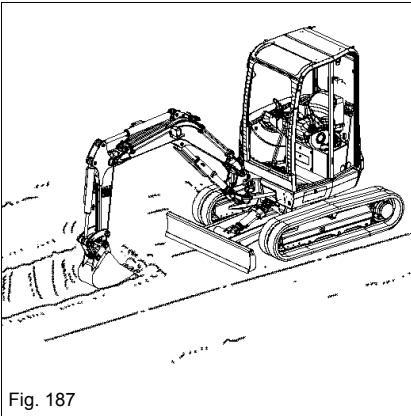


Fig. 187

### Working alongside trenches

For a more efficient working method, install a suitable bucket and set the tracks parallel to the trench.

When digging wide trenches, dig the side sections first and then the middle section.

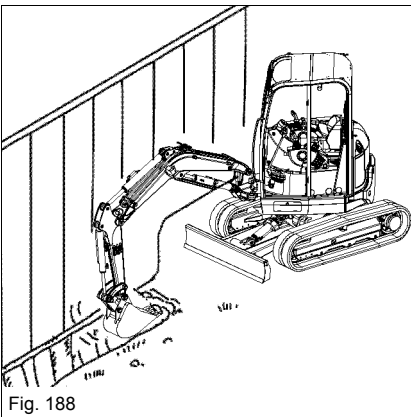


Fig. 188

For excavating laterally in tight spaces, turn the upper carriage and swivel the boom.

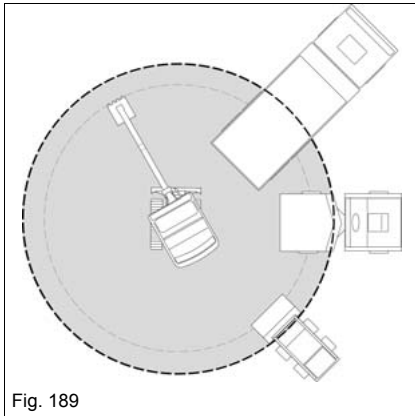


Fig. 189

### Loading material

Notes on loading site dumpers:

- Position the site dumper so that its cabin is outside the danger zone of the excavator.
- The loading platform of the truck is loaded by starting at the rear end.
- Keep the swivel angle as small as possible.
- Raise the full bucket to dump height only as you rotate toward the site dumper.
- Tilt out dusty material with the wind behind you to keep the dust away from your eyes, air filters and fans.
- If possible, the site dumper and the working direction of the bucket should form an angle of 45°.

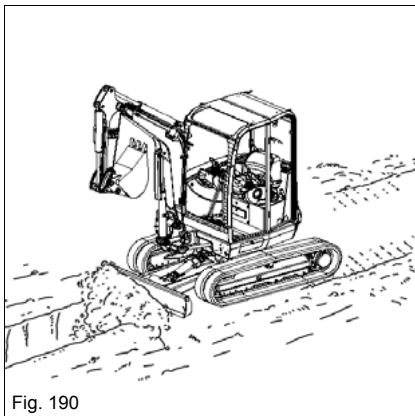


Fig. 190

### Grading

The stabilizer blade is used for filling up trenches or grading the ground.

Lower the stabilizer blade to the ground for grading work.

Set the depth of the layer you want to remove with the stabilizer-blade lever.

- The machine must not be raised by lowering the stabilizer blade.
- Do not dig in the machine or let it sink in.

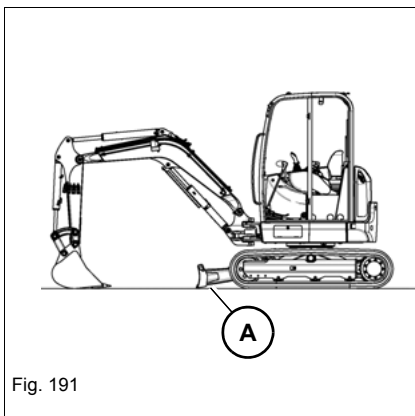


Fig. 191

### Digging position

Place stabilizer blade **A** on the side you want to dig.

---

**Working on slopes**

---

**⚠ WARNING****Tipping hazard of machine on slopes!**

A tipping machine can cause serious injury or death.

- ▶ Secure slopes before beginning work. Pay attention to ground conditions, machine weight, etc.
  - ▶ Stabilize the machine with the stabilizer blade during excavation work.
- 

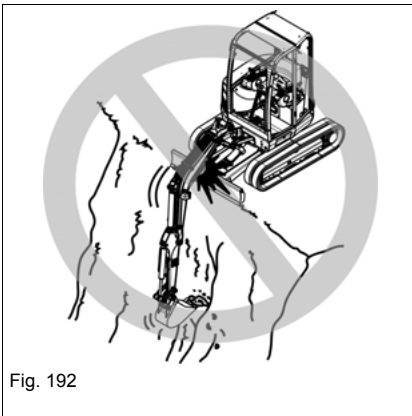


Fig. 192

---

**NOTICE**

Lifting arm cylinders can be damaged by improper operation.

- ▶ The piston rod must not touch the stabilizer blade.
- 

**Hints for digging**

When planning and performing digging work, Wacker Neuson recommends that you observe the following points:

- Exits from pits must be outside the digging line and as level as possible.
- Dig by removing adjacent strips if possible.
- Ensure that you can drive forward when driving out of the digging area with a fully loaded bucket.
- Perform transport trips downhill with loaded bucket in reverse operation.

**Freeing the machine**

If the machine gets stuck in the ground:

- Tilt out the bucket until the blade is vertical above the ground.
- Lower the boom all the way.
- Slowly tilt out the bucket.
  - ➔ The machine is pushed backward.
- Reverse slowly.
- Repeat this procedure until the tracks reach firm ground.

Reverse the machine away.

### 5.12 Emergency lowering

---

 **DANGER****Crushing hazard during boom lowering!**

Causes serious crushing or injury resulting in death.

- ▶ Do not allow anyone to stay in the danger zone.
  - ▶ Stop machine operation immediately as soon as someone enters the danger zone.
- 

Observe the following during emergency lowering:

1. Turn the starting key to position **1**.
  2. Lower the control lever base.
  3. Lower the boom completely.
  4. Return the control lever to neutral.
- 

 **Information**

Lower the boom immediately after stopping the engine.

---

## 5.13 Options

### Immobiliser

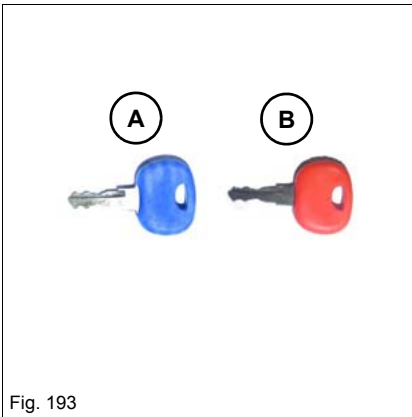


Fig. 193

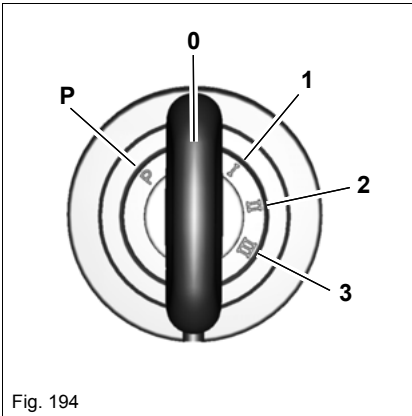


Fig. 194

**A** = starting key (blue)

For starting the machine. Scope of delivery includes 2 keys.

**B** = master key (red)

#### Coding new starting keys

1. Insert master key **B** in the starter and turn it to position **1** for a maximum five seconds.
2. Remove master key **B**.
3. Keep master key **B** at least 50 cm (20 in) away from the starter.
4. Within 15 seconds, turn starting keys requiring coding to position **1** for at least one second.
5. Repeat step 4 if more starting keys require coding.
  - ➔ With this the coding of the starting keys is completed.

Coding can be performed for a maximum of 10 starting keys.



#### Information

The procedure is automatically cancelled if no key requiring coding is detected by the system within 15 seconds.

#### Deleting coded keys

Deleting all coded keys is necessary whenever a coded key is lost.

The master key code is not deleted during deletion.

1. Insert master key **B** in the starter and turn it to position **1** for at least 20 seconds.
2. Code the starting keys.



#### Information

Store the master key in a safe place. It can only be used for coding new starting keys.

A new immobilizer must be installed if the master key is lost.

### Shovel bucket operation

Wacker Neuson backhoe buckets can also be used for shovel bucket operation.



---

#### **NOTICE**

The stick can be damaged if it is hit by the bucket base.

- ▶ Do not tilt out the bucket completely if it is used as a shovel bucket.
- 

### Trailer operation

The machine is not certified for trailer operation.



## 5.14 Putting out of operation/back into operation

The specified measures refer to putting the machine out of operation and back into operation after more than 30 days.

### Putting out of operation temporarily

Store the machine indoors if possible.

If the machine has to be stored outdoors, place it on firm ground if possible (for example on concrete), and cover it with a watertight tarp to protect it against humidity.

1. Park the machine – see *“Parking the machine” on page 5-8*.
2. Clean the engine with a high-pressure cleaner in a suitable place – see *chapter “7.5 Cleaning and maintenance” on page 7-21*.
3. Check the machine for leaks and loose nuts, screws and connections.
4. Carefully clean and dry the entire machine.
5. Spray an anticorrosion agent onto bare metal parts of the machine (piston rods of hydraulic cylinders, for example).
6. Apply grease to all lubrication points.
7. Fill the fuel tank completely.
8. Check the hydraulic oil and coolant levels, and add hydraulic oil and coolant if necessary.
9. Change engine oil.
10. Remove the battery and store it in a safe place. Charge the battery and perform battery maintenance at regular intervals.
11. Set the fuel cock to **OFF**.
12. Close the air-intake openings of the air filter system and exhaust pipe.

### Putting back into operation

---

**i** **Information**

If the machine was out of operation over a longer period of time without performing the specified steps, contact a Wacker Neuson service center before putting back into operation.

---

1. Remove anticorrosion agents from bare metal parts.
2. Install and connect the battery.
3. Open the air-intake openings of the air filter system and exhaust pipe.
4. Check the condition of the air filter elements and replace the elements if necessary.
5. Check the dust valve.
6. Set the fuel cock to **ON**.
7. Turn the starting key to position **1** for 2 minutes to supply the engine with fuel.
8. Check the machine for leaks.
9. Lubricate the machine according to the lubrication plan.
10. Check all engine/machine fluids in the units or reservoirs, and add fluids if necessary.
11. If the machine was out of operation for over 6 months, change the oil in the gearbox, engine, hydraulic oil reservoir and other units.
12. Replace the hydraulic oil filters (return and breather filters) if the machine was out of service for over 6 months.
13. Remove and keep the starting key and fuse **F1** in a safe place.
14. Insert the starting key and make the engine turn 15 seconds.
15. Wait 15 seconds.
16. Make the engine turn another 15 seconds.
17. Remove the starting key and put fuse **F1** back in.
18. Start the engine.
19. Let the engine run at idling speed for at least 15 minutes without load.
20. Check the oil levels in all units and add oil if necessary.
21. Check the machine for leaks.
22. Avoid operation at maximum engine speed or load for an hour.

Start the machine and ensure that all functions and warning systems work correctly before putting the machine back into operation.

## 5.15 Permanently putting out of operation

### Disposal

All fluids, lubricants, material, etc., used on the machine are subject to specific regulations. Dispose of different materials and consumables separately and in an environmentally friendly manner.

Disposal may only be performed by a Wacker Neuson service center. Observe the corresponding national guidelines regarding disposal.

---



### **Environment**

Do not allow environmentally damaging wastes to get into the ground or stretches of water and dispose of them in an environmentally friendly manner.

---

If the machine is no longer used according to its designated use, ensure that it is put out of operation and disposed of according to applicable rules and regulations.

- Machine disposal must be performed in accordance with state-of-the-art standards that apply at the time of disposal.



Notes:

## 6 Transportation

### 6.1 Towing the machine



#### **WARNING**

##### **Accident hazard due to incorrect towing!**

Incorrect towing can cause accidents and serious injury or death.

- ▶ Tow the machine away only from the immediate danger zone until it can be loaded.
- ▶ Only tow the machine using suitable towing equipment in connection with suitable towing facilities, such as towing hooks, eyes, etc.
- ▶ There must be nobody between the vehicles during towing. The lateral safety distance is equal to 1.5 times the length of the towing equipment.
- ▶ Do not tow the machine if it is stuck or on a slope. Load the machine.
- ▶ Wear protective equipment.
- ▶ Start machine travel and tow away slowly.

#### **NOTICE**

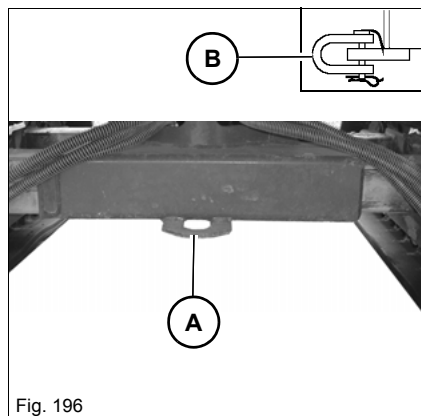
The machine can be damaged during towing.

- ▶ Tow the machine away only from the immediate danger zone until it can be loaded.
- ▶ Tow away the machine only if the engine is running and if the drive is functional.
- ▶ Do not tow the machine if it is stuck or on a slope. Load the machine.
- ▶ Only tow the machine using suitable towing equipment in connection with suitable towing facilities, such as towing hooks, eyes, etc.
- ▶ A tractor vehicle of the same weight category must be used as a minimum.  
In addition, the tractor vehicle must be equipped with a safe braking system and sufficient tractive power.



#### **Information**

The manufacturer's warranty shall not apply to accidents or damage caused by loading or transporting.



1. – see chapter “Towing” on page 2-11
2. Ensure that the machine can be towed safely.
3. Only use towing eye **A** .
4. Secure shackle **B** with the shackle pin and a lock pin.
5. Install towing equipment of appropriate size on the shackle.
6. Start machine travel and tow away slowly.
7. Tow away the machine only until it can travel on its own.

## 6.2 Loading the machine

### **WARNING**

#### **Accident hazard due to incorrect loading!**

Incorrect loading can cause accidents and serious injury or death.

- ▶ Do not allow anyone to stay in the danger zone.
- ▶ Bear in mind the transport weight on the machine's type label.
- ▶ Tie down the machine only at the indicated tie-down points.
- ▶ Observe the loading weight. Add the weight of subsequently installed accessories to the weight of the vehicle.

### Tie-down points

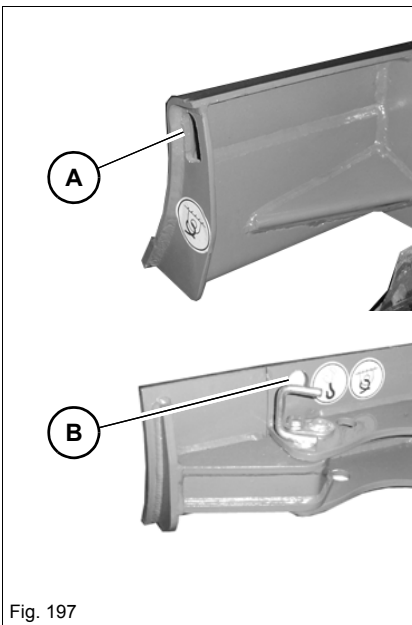


Fig. 197

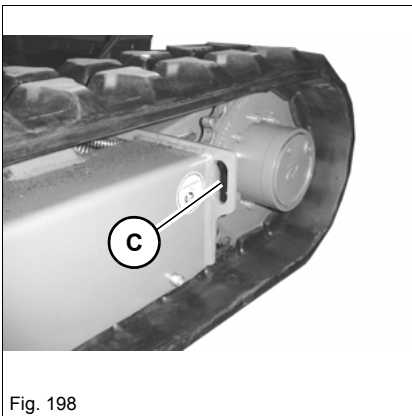
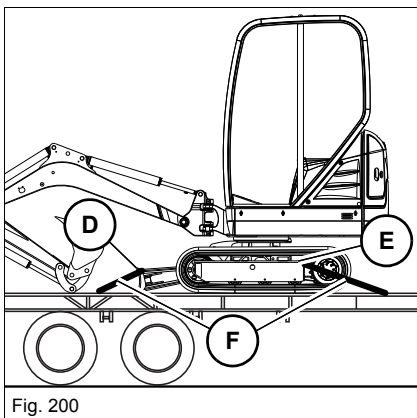
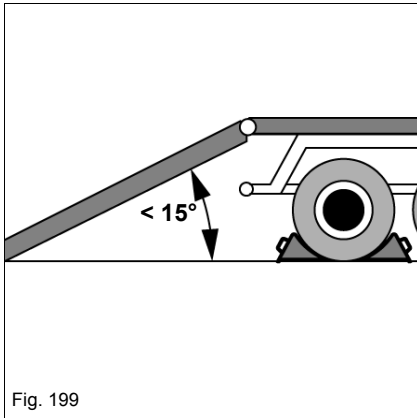


Fig. 198

Position		Quantity
<b>A</b>	Stabilizer blade	2
<b>B</b>	Dozer blade with <b>telescopic travel gear option</b>	2
<b>C</b>	Travel gear	2



1. See chapter [Transportation on page 2-13](#)
2. Secure the transport vehicle with chocks to prevent it from rolling.
3. Position the ramps at the smallest possible angle. Ensure that the grade does not exceed 15° (27 %).
4. Use access ramps and transport surfaces with an antiskid surface only.
5. Ensure that the loading area is clear and access to it is not obstructed (superstructures, for example).
6. Start the engine.
7. Raise the boom and the stabilizer blade to avoid touching the access ramps.
8. Carefully drive the machine onto the middle of the transport vehicle.
9. Move the machine to transport position.
  - Position the boom straight ahead at the center of the machine.
  - Lower the boom and the stabilizer blade.
10. Stop the engine.
11. Raise the control lever base.
12. Remove the starting key and carry it with you.
13. Leave the vehicle and close and lock all covers.
14. Fasten the machine on the loading area firmly with tie-downs **D** and **E** with slings **F** of appropriate size. Observe legal rules and regulations.



## Crane-lifting

There are two options for loading the crane:

- Lifting arm/dozer blade (marked with **J**)
  - Cabin lifting lugs (marked with **K**)
- 

### **WARNING**

#### **Accident hazard due to incorrect loading!**

Incorrect loading can cause accidents and serious injury or death.

- ▶ Do not allow anyone to stay in the danger zone.
  - ▶ Bear in mind the transport weight on the machine's type label.
  - ▶ Observe the loading weight. Add the weight of subsequently installed accessories to the weight of the vehicle.
  - ▶ The machine may only be raised with suitable lifting gear.
- 

### **NOTICE**

Possible damage to the machine due to incorrect loading.

- ▶ Bear in mind the transport weight on the machine's type label.
  - ▶ Observe the loading weight. Add the weight of subsequently installed accessories to the weight of the vehicle.
  - ▶ The machine may only be raised with suitable lifting gear.
-

**Lifting eyes**

The machine must only be raised using the lifting eyes indicated below.

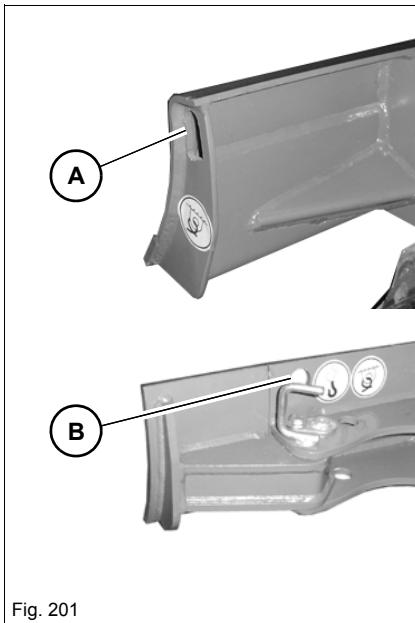


Fig. 201



Fig. 202

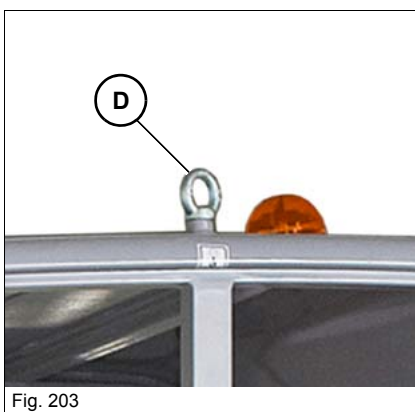


Fig. 203

Position	Lifting eye	Quantity
A	Stabilizer blade	2
B	Dozer blade (with telescopic travel gear option)	2
C	Boom	1
D	Cabin lifting lugs (option)	2

**i Information**

Extended cabin lifting lugs are available for loading the crane with attached FOPS screen category I.

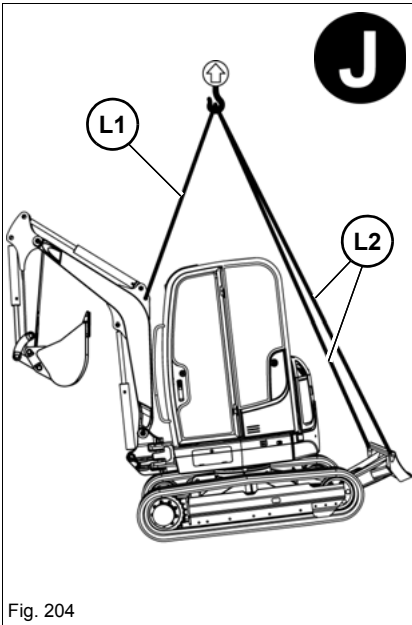


Fig. 204

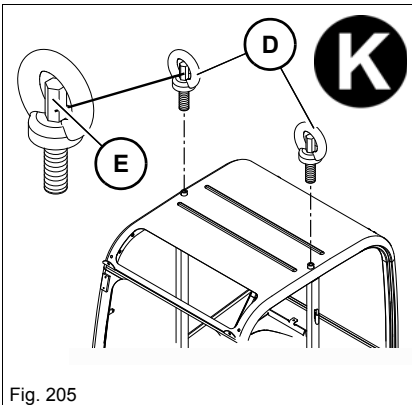


Fig. 205

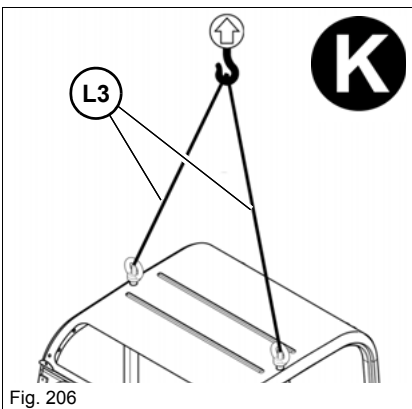


Fig. 206

1. See chapter [Crane-lifting on page 2-12](#)
2. Fit an empty bucket and lock it safely.
3. Remove all dirt from the machine.
4. Park the vehicle on firm, level, and horizontal ground.
5. Tilt in bucket.
6. Raise the loader unit completely.
7. Pull the stick toward the machine.
8. Raise the stabilizer blade completely.
9. Position the boom straight ahead at the center of the machine.
10. Rotate the upper carriage by 180° so that the stabilizer blade points to the rear.
11. Lock the revolving superstructure- see [Revolving superstructure lock](#).
12. Stop the engine.
13. Operate the control lever repeatedly to release the pressure in the hydraulic system.
14. Raise the control lever base.
15. Remove the starting key and carry it with you.
16. Safely store all loose objects.
17. Leave the vehicle and close and lock all covers.

**i Information**

When loading the crane using cabin lifting lugs, attach extensions **E** (M20) to the lifting lugs **D** and tighten with 135 Nm (100 ft./lbs.).

18. Attach slings on the lifting eyes.
  19. Slowly raise the machine until there is no more contact with the ground.
  20. Let the machine swing until it comes to rest.
  21. If the machine balance, and the condition and position of the slings is correct, slowly raise the machine to the required height and load it.
- Mandatory lengths **L** of the lifting gear:

Length	Dimension
<b>L1</b>	2200 mm (87 in)
<b>L2</b>	3,400 mm (10'-10")
<b>L3</b>	1200 mm (47 in)

### 6.3 Transporting the machine

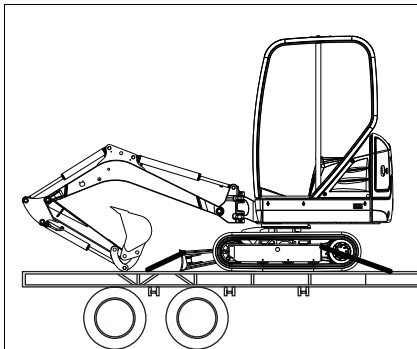


Fig. 207

1. The driver of the transport vehicle must observe the following before departure:
  - Permitted overall height, width and weight of the transport vehicle including the excavator.
  - The legal regulations of the countries where transport is to take place.
2. Close the exhaust pipe before transporting the machine through wet weather.

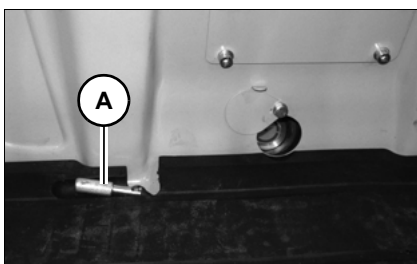
#### Revolving superstructure lock

The revolving superstructure lock locks the revolving superstructure during transport.

#### **NOTICE**

Possible serious machine damage.

- ▶ Do not rotate the locked revolving superstructure.



#### Locking the upper carriage

- Align the upper carriage and the travel gear correctly.
- Raise bolt **A** and bring into position **2**.

#### Unlocking the upper carriage

- Align the upper carriage with the travel gear.
- Raise bolt **A** and bring into position **1**.

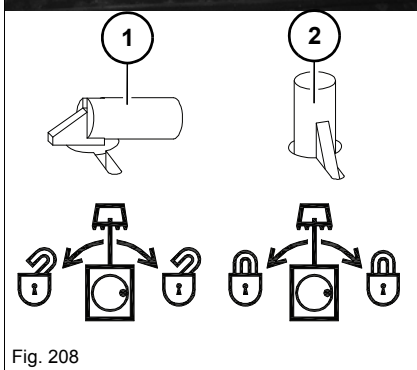


Fig. 208

## 7 Maintenance

### 7.1 Information on maintenance

#### Responsibilities and prerequisites

The working order and the service life of machines are heavily dependent on maintenance.

Daily and weekly servicing and maintenance must be performed by specifically trained personnel.

Have the maintenance, delivery inspection and the entries in the service booklet performed by a Wacker Neuson service center, otherwise warranty claims will not be acknowledged.

It is therefore in the interest of the machine owner to ensure optimal machine operation.

Repair or replace defective parts immediately, even if they are not yet due for replacement.

Repair or replacement of safety-relevant parts may be performed only by a Wacker Neuson service center.

Use only original spare parts for repairs.

Wacker Neuson shall not be liable for damage to the machine or personal injury caused by failure to observe the specific information and descriptions.

#### Important safety instructions on maintenance

- Follow all safety instructions given in this Operator's Manual.
- Follow the instructions given in chapter **Safety, safety instructions on maintenance** and **qualification of the operating and maintenance personnel** in this Operator's Manual.
- Follow the maintenance and safety instructions given in the Operator's Manuals of the attachments.
- Wear protective equipment (for example hard hat, safety glasses, protective gloves, safety boots).
- Observe the danger indications and safety instructions during maintenance.
- In order to avoid injury hazard, do not perform work on a hot or running engine.
- Use a suitable container to collect fluids and lubricants as they flow out and dispose of them in an environmentally friendly manner.
- Attach a warning label to the control elements (for example "**Machine being serviced, do not start**").
- Stop the machine (see **Preparing lubrication**).
- Do not re-use self-locking fasteners.

Maintenance label

Some maintenance work may only be performed by a Wacker Neuson service center (see maintenance schedule).

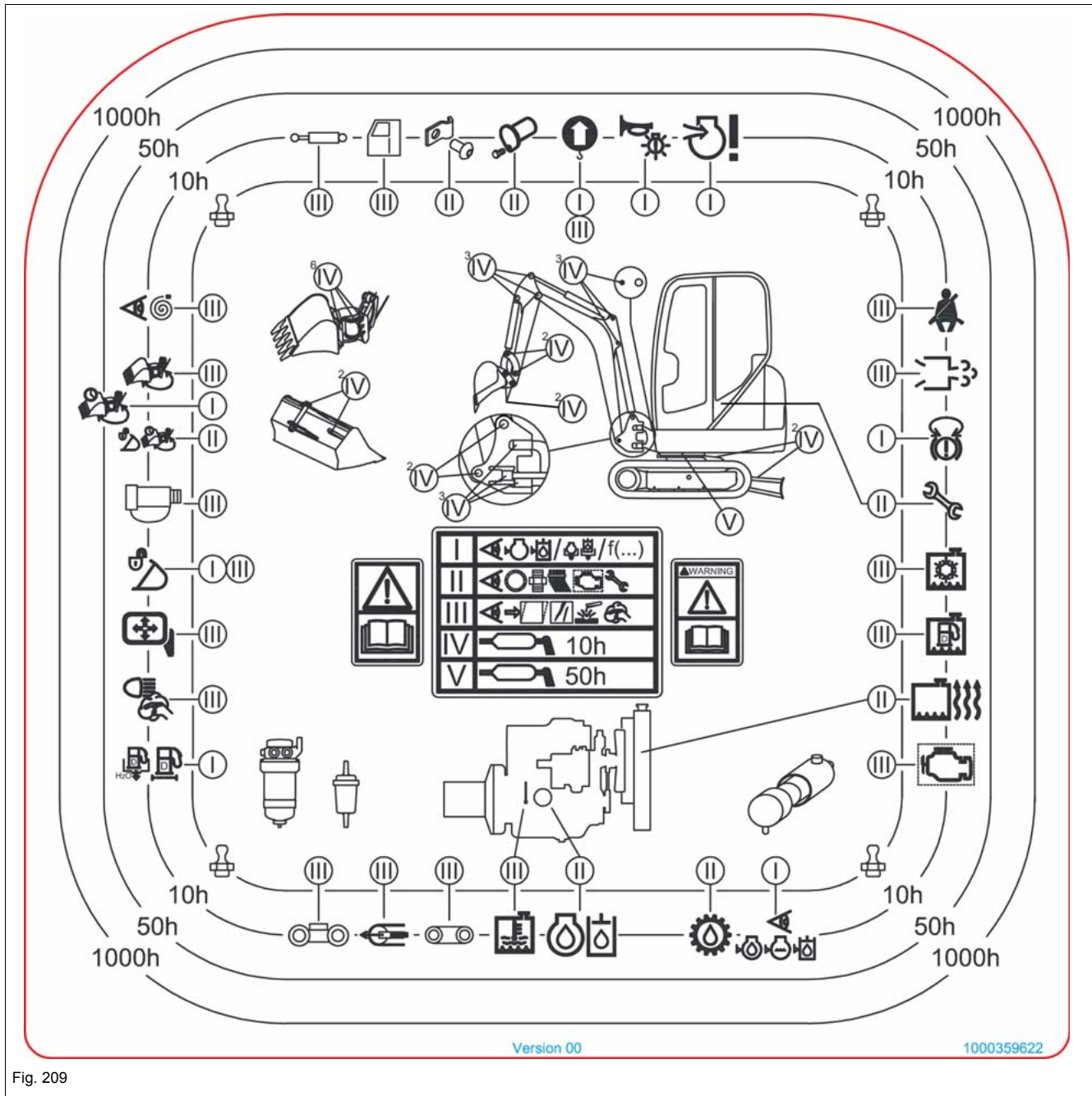







Fig. 209

**Explanation of symbols on the maintenance label**

Symbol	Assembly	Explanation
	General	Visual check
	General	Visual check of machine (walk-around)
	General	Lubrication points
	General	Clean the radiator fins and the water separator
	fuel system	Replace the fuel filter
	Radiator	Check the coolant
	Radiator	Draining coolant
	Engine	Check the engine oil level
	Engine	Changing engine oil
	Engine	Replacing the engine oil filter
	Engine	Replacing the V-belt
	Engine	Checking V-belt tension
	Engine	Replace the air filter element
	Engine	Checking valve clearance
	Travelling drive	Check the gearbox oil of the drive
	Travelling drive	Replace the gearbox oil of the drive
	Travel gear	Checking track tension
	Hydraulic system	Check the oil level of the hydraulic system
	Hydraulic system	Replace the hydraulic oil
	Hydraulic system	Replace the hydraulic oil filter insert
	Hydraulic system	Replace the breather filter of the hydraulic oil reservoir
	Cabin	Indicator lights are being checked
	Cabin	Resetting the maintenance meter



## 7.2 Maintenance overview

### Maintenance plan

<b>Daily maintenance (user)</b>	
<b>Inspection work</b> (Check the following fluids and lubricants, check the oil levels after a test run and add oil if necessary)	Page
Check the fluids and lubricants (engine oil, engine coolant, hydraulic oil)	7-30, 7-32, 7-38
Check the radiator and hydraulic oil cooler for dirt, clean them if necessary	7-33
Lubricate the machine according to the lubrication schedule	7-9
Check the dirt indicator on the air filter <sup>1</sup>	7-34
Check the water separator and fuel filter: drain water if necessary (see sight glass)	7-27
Check the track tension and retension the tracks if necessary	7-43, 7-44
Check the engine air intake	7-35
Check pin lock	--
Check line fixtures	--
Check indicator lights for correct function	4-28
Check the hydraulic couplings for dirt	--
Clean the lights/light system, signaling systems	--
Hydraulic quickhitch system: check acoustic warning system	5-30
Check the threaded fittings of the protective structures (canopy, for example) for tightness	--
<b>Option</b>	
Adjust the mirrors correctly, clean them and check them for damage, check the fastening screws and tighten them if necessary	4-12
<b>Leakage check</b>	
Check for tightness, leaks and chafing: pipes, flexible lines and threaded fittings of the following assemblies and components. Repair if necessary	Page
Engine and hydraulic system	--
Travelling drive	--
Cooling systems, heating, and hoses (visual check)	--
<b>Option</b>	
Hydraulic quickhitch (Easy Lock)	--
<b>Visual check</b>	
Correct function; deformations, damage, surface cracks, wear and corrosion	Page
Check the exhaust system for damage	--
Check the insulating mats in the engine compartment for damage	--
Check the canopy/cabin and protective structures for damage (for example, the FOPS structure)	--
Check the tracks for damage	--
Check the travel gear for damage (for example the track rollers, insert rolling bearings)	--



<b>Daily maintenance (user)</b>	
Check the piston rods of the cylinders for damage	--
Check the seat belt for damage	--
Check the hydraulic hoses for damage	--
<b>Option</b>	
Check the load hook, joint rod, lifting eyes	<a href="#">7-46</a>
Check the hydraulic quickhitch (Easy Lock) for damage	--
<b>Weekly maintenance (every 50 operating hours) (user)</b>	
	Page
Lubricate the machine according to the lubrication schedule	<a href="#">7-9</a>
Clean the lights/light system, signaling system, acoustic warning system	--
Check V-belt condition and tension	<a href="#">7-36</a>

1. Air filter replacement according to the dirt indicator, every 1000 o/h or once a year at the latest. (Replace after 50 o/h when in extensive use in environments with acidic air, such as acid production facilities, steel and aluminum mills, chemical plants and other nonferrous-metal plants, independently of the dirt indicator)



### **Information**

Check the antifreeze at temperatures below 4 °C (39 °F).

**Only once after the first 50 operating hours (Wacker Neuson service center)**

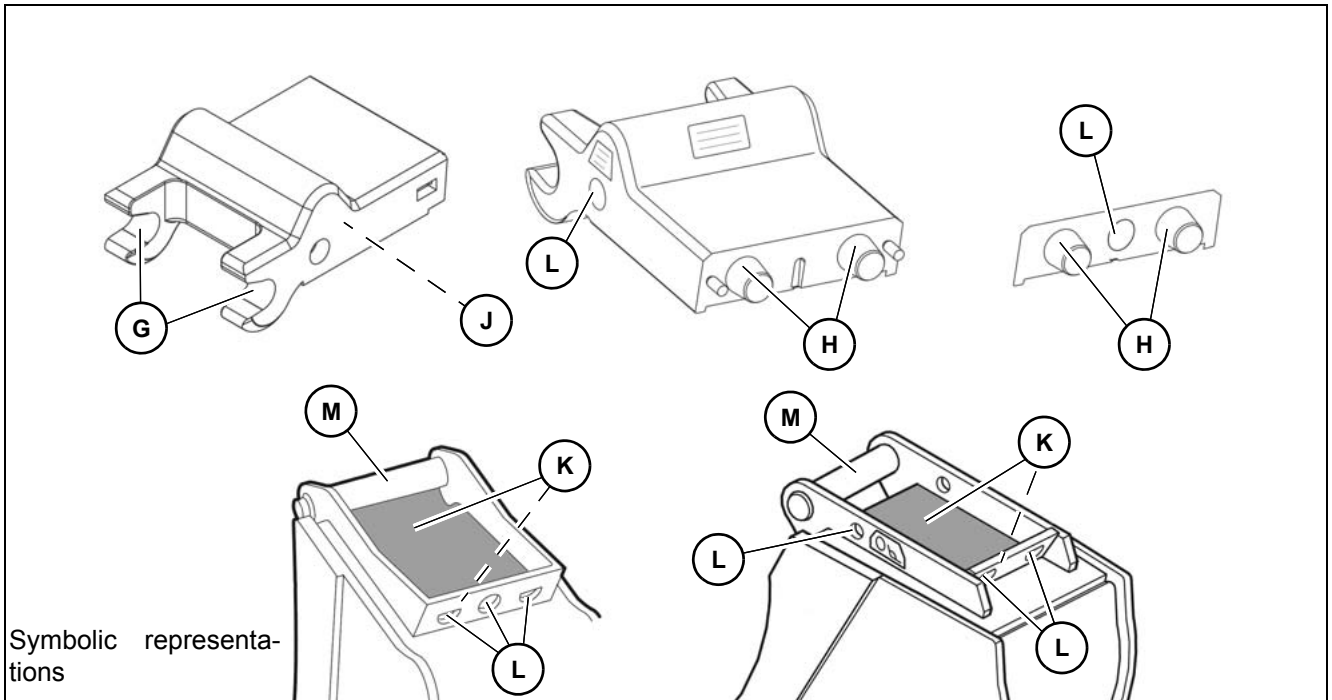
Changing engine oil	--
Replacing the engine oil filter	--
Replace the hydraulic oil filter	--
Replace the drive system gear oil	--
Check V-belt condition and tension	--
Check the threaded fittings for tightness	--
Check labels and Operator's Manual for completeness and condition	--
Check the pressure of the primary pressure limiting valves	--
All steps for maintenance once a day and once a week	7-4

**Other maintenance intervals (Wacker Neuson service center):**

For additional details contact a Wacker Neuson service center.


**Information**

Maintenance with the note **authorized service center** must only be performed by the trained and qualified personnel of an authorized service center.

**Maintenance schedule of Lehnhoff mechanical quickhitch system**


<b>Quick coupler system MS01 maintenance (operator)</b>		<b>Interval<sup>1</sup></b>
Perform visual inspection of the quickhitch system	--	10 hours of operation/ daily
Clean bolt guide	<b>G</b>	50 hours of operation/ weekly
Clean the bolt contact surface	<b>H</b>	50 hours of operation/ weekly
Clean bottom side of the quick coupler system	<b>J</b>	50 hours of operation/ weekly
Clean contact surfaces of the attachment	<b>K</b>	50 hours of operation/ weekly
Clean the opening for the socket wrench and bores of the attachment support	<b>L</b>	50 hours of operation/ weekly
Clean bolt attachment support	<b>M</b>	50 hours of operation/ weekly

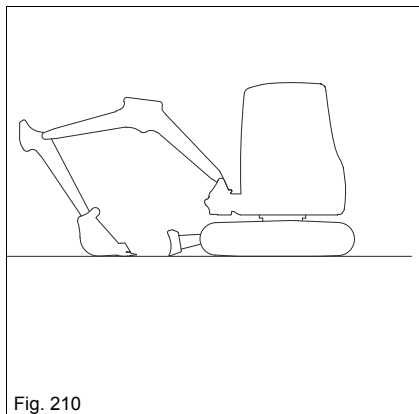
1. For time specifications: the first achieved time specification is decisive. If the situation requires it, perform maintenance if necessary, even if the maintenance interval has not yet been reached.

**Other maintenance intervals (Wacker Neuson service center):**

- Every 250 hours of operation or semi-annually
- Every 500 operating hours or annually

For additional details contact a Wacker Neuson service center.

### Preparing lubrication



1. Stop the machine on firm, level, and horizontal ground.
2. Position the boom straight ahead at the center of the machine.
3. Lower the boom and the stabilizer legs to the ground.
4. Stop the engine.
5. Operate the control lever repeatedly to release the pressure in the hydraulic system.
6. Raise the control lever base.
7. Remove the starting key and carry it with you.
8. Safely store all loose objects.
9. Close the windows and doors.
10. Close and lock all covers.
11. Attach a warning label to the control elements (for example **“Machine being serviced, do not start”**).

Wait at least 10 minutes after stopping the engine.



#### Information

Keep all lubrication points clean and remove any escaping grease.

**Lubrication plan**

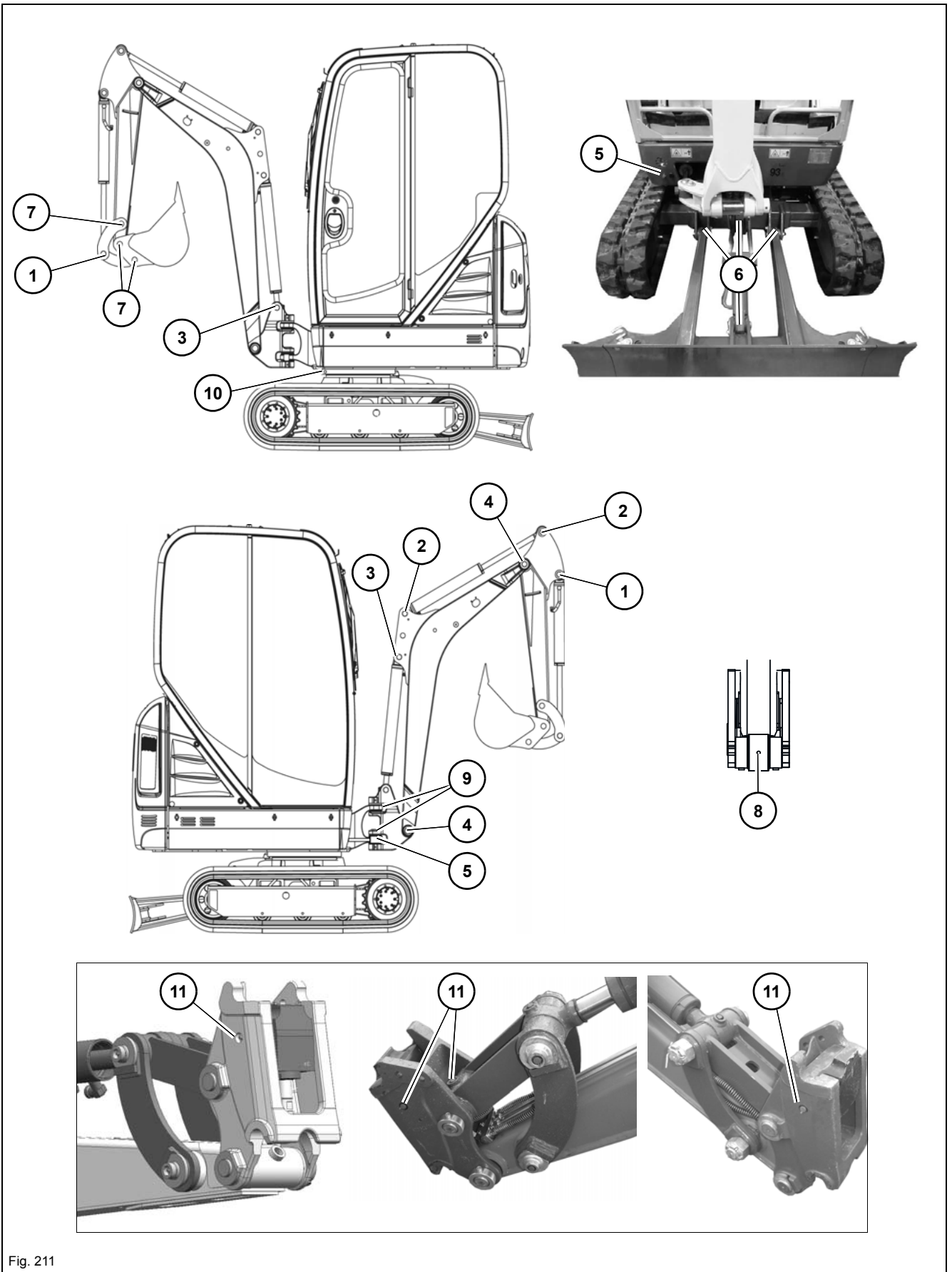


Fig. 211

Position	Lubrication point	Interval	Quantity
1.	Bucket cylinder	Daily	2
2.	Stick cylinder	Daily	2
3.	Boom cylinder	Daily	2
4.	Boom	Daily	2
5.	Swiveling cylinder	Daily	2
6.	Stabilizer blade	Daily	4
7.	Shovel arm	Daily	3
8.	Joint rod	Daily	1
9.	Swiveling console	Daily	2
10.	Ball bearing race	Every week	1
11.	Hydraulic quickhitch (option)	Daily	4

## Control lever base

### CAUTION

**Crushing hazard in the area of the moving parts of the control lever base.**

There is a risk of injury in the area of the moving parts.

► Stay clear (extremities, clothing) of the moving parts.

1. Stop and park the machine. Stop the engine. See "Preparing lubrication".
2. Raise the control lever base.
3. Spray the guide lever **A** and springs **B** with semi-fluid grease.
4. Raise and lower the control lever base several times.

### Information

Keep the lubrication points clean and remove any escaping grease.

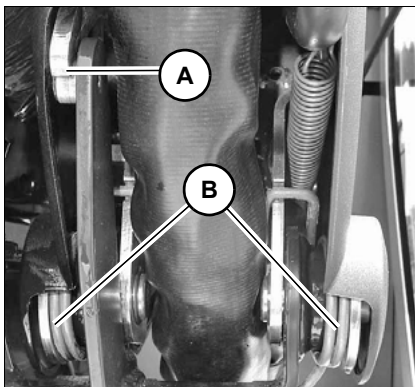


Fig. 212

## Live ring (ball bearing)

### **DANGER**

#### **Danger of crushing when lubricating the ball bearing race!**

Serious crushing danger causing death or serious injury!

- ▶ Park the machine as shown in [Fig. 210](#).
- ▶ Do not rotate the upper carriage.

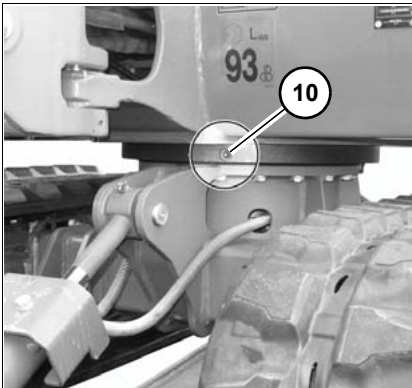


Fig. 213

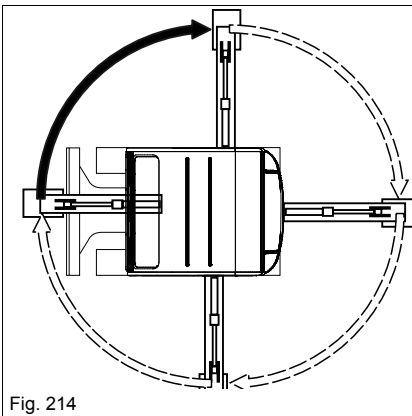


Fig. 214

1. Park the vehicle on firm, level, and horizontal ground.
2. Lower the boom and the stabilizer blade to the ground.
3. Stop the engine, remove the starting key and carry it with you.
4. Apply grease to lubrication point **10** with two strokes of the grease press.
5. Start the engine, raise the boom and the stabilizer blade.
6. Rotate the upper carriage by 90°.
7. Repeat steps 2-6 three times until the revolving superstructure is back in its initial position.
8. Rotate the upper carriage several times by 360°.

### **Information**

Keep the lubrication points clean and remove any escaping grease.

## Teeth of live ring

The live ring gear is maintenance-free.

### 7.3 Fuel, lubricants and coolants

Application	Fluid/lubricant	Specification	Season/temperature	Capacities <sup>1</sup>
Engine <sup>2</sup>	Diesel fuel <sup>3</sup>	ASTM D975-94: 1D, 2D (USA)	Year-round	24 liters (6.3 gal)
		EN 590 (EU)		
		ISO 8217 DMX (International)		
		BS 2869-A1, A2 (GB)		
		JIS K2204 (Japan)		
		KSM-2610 (Korea)		
	GB252 (China)			
Coolant	Distilled water and anti-freeze D40 Super/ASTM 6210		4 liters (1 gal)	
Engine	Engine oil	API: CG-4/CH-4/CI-4 ACEA: E3, E4, E5	-15 °C (-5 °F) +45 °C (+104 °F)	About 3.4 l (0.9 gal)
		ACEA E3, E4, E5 (SAE10 W 40) <sup>4</sup>		
Hydraulic oil reservoir	Hydraulic oil	Eurolub HVLP 46 <sup>5</sup>	Year-round <sup>6</sup>	20 liters (5.3 gal)
	Biodegradable hydraulic oil <sup>7</sup>	Panolin HLP Synth 46		
		BP BIOHYD SE-S 46		
Grease zerks	Grease	KPF 2 K-20 <sup>8</sup> ISO-L-X-BCEB 2 <sup>9</sup>	Year-round	As required
Battery terminals	Acid-proof grease <sup>10</sup>	FINA Marson L2	Year-round	As required
Control lever base	Adhesive fluid grease	Förch S401	Year-round	As required

- The capacities indicated are approximate values; the sight glass or the dipstick alone is relevant for the correct level. Capacities indicated are no system fills
- Sulfur content below 0.05 %, cetane number over 45
- In countries where level IIIA (or higher) or Tier IV interim (or higher) exhaust emission regulations apply, use diesel fuels with a maximum sulfur content of 0.0015 % (= 15 mg/kg)
- According to DIN 51511
- According to DIN 51524 section 3
- Depending on local conditions – see [“Engine oil types” on page 7-13](#).
- Biodegradable hydraulic oil based on saturated synthetic esters with an iodine value of < 10, according to DIN 51524, section 3, HVLP, HEES.
- KPF 2 K-20 according to DIN 51502 lithium-saponified grease.
- ISO-L-X-BCEB 2 according to DIN ISO 6743-9, lithium-saponified grease
- Standard acid-proof grease NGLI category 2.

### Hydraulic oil types

Viscosity class	Ambient temperature			
	min. °C	min. °F	max. °C	max. °F
ISO VG32	-20	-4	30	86
ISO VG46	-5	23	40	104
ISO VG68	5	41	50	122



### Replacement intervals

Replace the hydraulic oil and hydraulic oil filter depending on the percentage of hammer operation.

Percentage of hammer work	Hydraulic oil	Hydraulic oil filter
20%	800 o/h	300 o/h
40%	400 o/h	
60%	300 o/h	100 o/h
Over 80 %	200 o/h	

### Important information regarding operation with biodegradable hydraulic oil

- Use only the biodegradable oils that have been tested and released by Wacker Neuson.
- Add only biodegradable oil of the same type. In order to avoid misunderstandings, attach a clear label to the hydraulic oil filler neck providing clear information regarding the type of oil currently used. The joint use of two different biodegradable oils can affect the quality of one of the oil types. Therefore ensure that the remaining amount of biodegradable oil complies with the national and regional regulations as you replace it. Observe the manufacturer's indications.
- Do not add mineral oil – the content of mineral oil should not exceed 2 % of the system fill in order to avoid foaming problems and to ensure biological degradability.
- When running the machine with biodegradable oil, the same oil and filter replacement intervals are valid as for mineral oil.
- Always have the condensation water in the hydraulic oil reservoir drained by a Wacker Neuson service center before the cold season. The water content may not exceed 0.1 % by weight.
- The instructions in this Operator's Manual concerning environmental protection are also valid for the use of biodegradable oil.
- Subsequent change from mineral oil to biodegradable oil may only be performed by a Wacker Neuson service center.

### Engine oil types

Viscosity grade (SAE)	Ambient temperature			
	min. °C	min. °F	max. °C	max. °F
10W	-20	-4	10	50
20W	-10	14	10	50
10W30	-20	-4	30	86
10W40	-20	-4	40	104
15W40	-15	5	40	104
20	0	32	20	68
30	10	50	30	86
40	20	68	40	104

### 7.4 Maintenance accesses

---

---

 **WARNING**

**Injury hazard due to rotating parts!**

Rotating parts can cause serious injury or death.

- ▶ Open the engine cover only at engine standstill.
  - ▶ Remove the starting key and carry it with you.
- 

---

 **CAUTION**

**Burn hazard due to hot surfaces!**

Can cause serious burns.

- ▶ Stop the engine and let hot surfaces cool down.
  - ▶ Wear protective equipment.
- 

---

 **CAUTION**

**Injury hazard due to open maintenance access!**

Can cause injury.

Take care to avoid injuries when the maintenance access door is open.

---

### Opening the engine cover

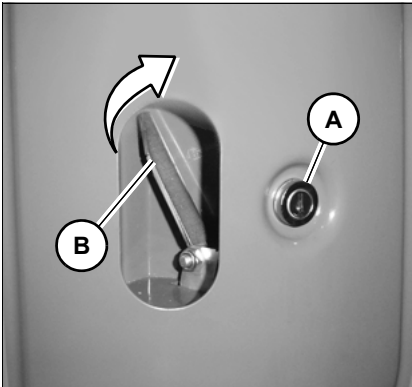


Fig. 215

1. Stop and park the machine. Stop the engine. See "Preparing lubrication".
2. Turn the starting key in lock **A** anticlockwise.
3. Pull the lever **B** to the rear and open the engine hood.

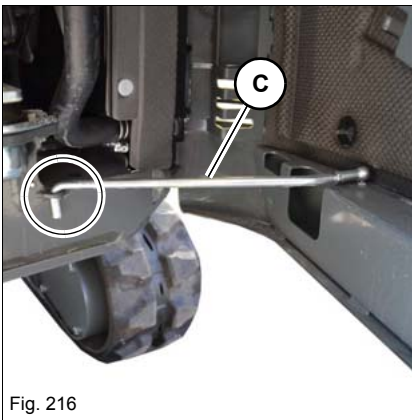


Fig. 216

4. Secure the engine hood with a lock **C**.

### Closing the engine cover

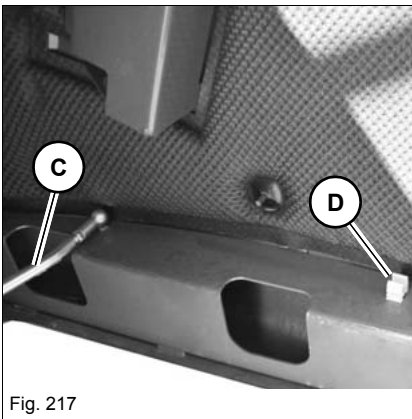


Fig. 217

1. Lift the latch **C** and lock to the bracket **D**.
2. Close the engine cover.
3. Turn the starting key in lock **A** clockwise.

### Cover on the right

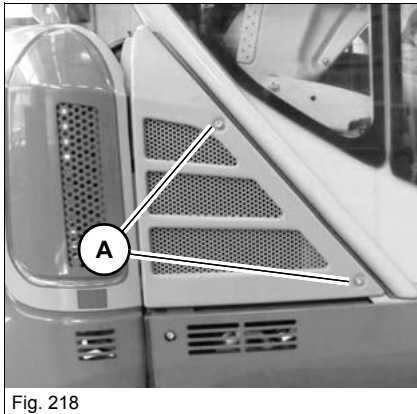


Fig. 218

#### Open

1. Stop and park the machine. Stop the engine. See “Preparing lubrication”.
2. Loosen screws **A** and remove cover.

#### Close

Lock in the reverse order.

### Cover on the left

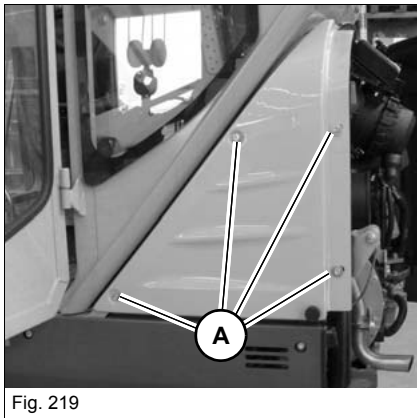


Fig. 219

#### Open

1. Stop and park the machine. Stop the engine. See “Preparing lubrication”.
2. Open the engine cover.
3. Loosen screws **A** and remove cover.

#### Close

Lock in the reverse order.

## Disassemble/assemble the canopy or cabin

It is possible to remove the canopy or cabin while going through a short passage.

---

### **DANGER**

#### **Danger of accident during machine travel without canopy/cabin!**

Serious crushing hazard causing death or serious injury.

- ▶ Do *not* fasten the seat belt in order to be able to leave the machine immediately in an emergency.
  - ▶ Do not perform any work without a canopy/cabin.
  - ▶ Obtain the approval of the appropriate national authority.
  - ▶ Machine travel is only allowed on absolutely level ground.
  - ▶ Avoid tipping movements of the machine under all circumstances.
  - ▶ Machine travel in areas involving a risk of falling objects is prohibited.
- 

---

### **WARNING**

#### **Accident hazard due to incorrect loading!**

Incorrect loading can cause accidents and serious injury or death.

- ▶ Do not allow anyone to stay in the danger zone.
  - ▶ Only disassemble or assemble the canopy or cabin with a crane.
  - ▶ The canopy or cabin require attached cabin lifting lugs for lifting – [see chapter “Crane-lifting” on page 6-5.](#)
- 

---

### **WARNING**

#### **Danger of crushing due to pre-tensioned canopy!**

The pre-tensioned canopy can cause serious injuries.

- ▶ Pay attention to the movements of the pre-tensioned canopy as you remove the screws.
-

### Removing

1. Stop and park the machine. Stop the engine. See "Preparing lubrication".
2. Connect plug **A** on the right next to the seat.

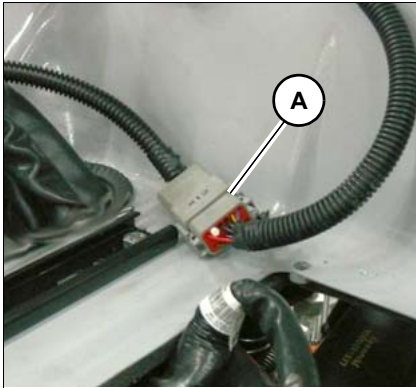


Fig. 220

3. Hook up the lifting gear to the cabin lifting lugs **B** – see *chapter "Crane-lifting" on page 6-5*.

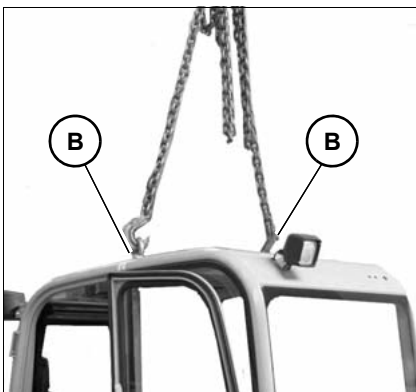


Fig. 221

4. Loosen the rear cabin screws **C**.

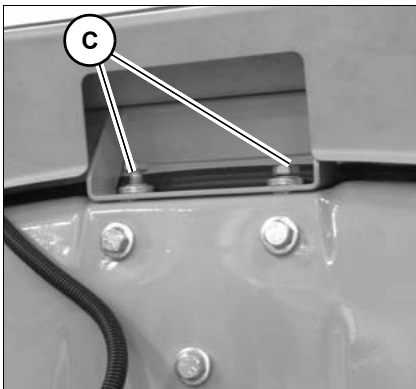


Fig. 222

5. Loosen screws **D** and remove the strip **E**.

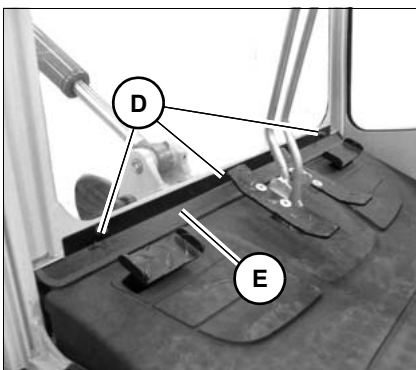


Fig. 223

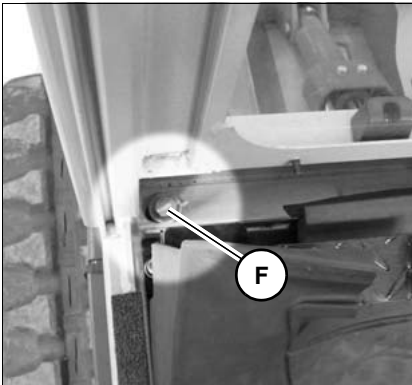


Fig. 224

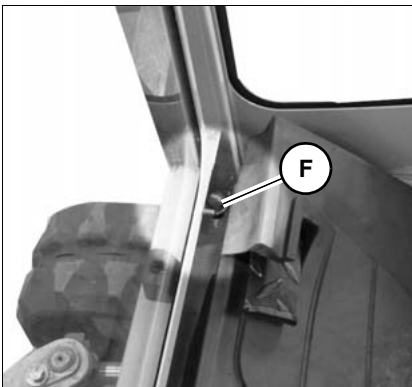


Fig. 225

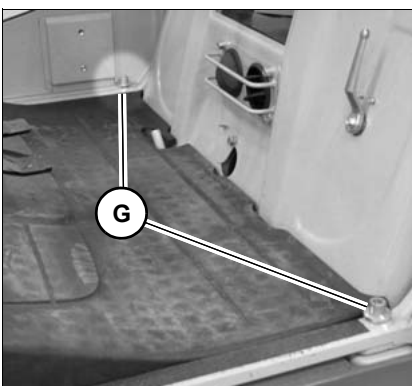


Fig. 226



Fig. 227

6. Remove the screws **F** left and right in the footwell.

7. Remove the screws **G** in the footwell.

8. Raise the cab.

9. Put the cabin down on level ground and secure it against tipping over.

**Assembly**

Perform the disassembly procedure in the reverse chronological order.

Tighten screws with the following torques:

Screws	Torque Nm (ft.lbs)
C (M12/10.9)	110 (81)
F (M12/10.9)	
G (M12/10.9)	



---

## 7.5 Cleaning and maintenance

---

 **WARNING****Injury hazard due to rotating parts!**

Rotating parts can cause serious injury or death.

- ▶ Open the engine cover only at engine standstill.

---

 **WARNING****Burn hazard due to hot surfaces!**

Hot surfaces can cause serious burns or death.

- ▶ Stop the engine and let it cool down.
- ▶ Wear protective equipment.

---

 **CAUTION****Health hazard due to cleaning agents!**

Cleaning agents can be harmful to health.

- ▶ Use only suitable cleaning agents.
- ▶ Ensure sufficient ventilation.

---

**NOTICE**

Damage to rubber and electrical parts when cleaning with solvents.

Do not use solvents, benzene, or other aggressive chemicals.

---

**NOTICE**

Damage to electronics due to water jet.

- ▶ Do not point the water jet directly at electric components, and protect the electric components against humidity.
- ▶ If water contacts electrical components, dry them with compressed air and apply contact spray to them.

**Environment**

In order to avoid damage to the environment, clean the machine only in wash bays and places authorized by the authorities.

---

Cleaning the machine is divided into three separate areas:

- Inside the cabin
- Exterior of the machine
- Engine compartment

### **Washing solvents**

- Ensure sufficient room ventilation.
- Wear suitable protective clothing.
- Do not use flammable liquids, such as gasoline or diesel.

### **Compressed air**

- Work carefully.
- Wear safety glasses and protective clothing.
- Do not aim the compressed air at the skin or at other people.
- Do not use compressed air for cleaning your clothing.

### **High-pressure cleaner**

- Cover electric parts.
- Do not point the water jet directly at electric parts and damping material.
- Cover the vent filter on the hydraulic oil reservoir and the filler caps for fuel, hydraulic oil, etc.
- Protect the following components from moisture:
  - Electrical components (for example alternator, control valves).
  - Control devices and seals.
  - Air intake filters, etc.

### **Volatile and easily flammable anticorrosion agents and sprays:**

- Ensure sufficient room ventilation.
- Fire, open flames and smoking is prohibited.

## **Inside the cabin**

Recommended aids:

- Vacuum cleaner
- Moist cloths
- Brush
- Water with mild soap solution

## **On the outside of the machine**

Recommended aids:

- High-pressure cleaner
- Steam jet

## **Engine compartment**

1. Park the machine in a wash bay or place suitable for washing.
2. Stop the engine. See "**Preparing lubrication**".
3. Clean the machine.

## **Seat belt**

Always keep the seat belt clean, as coarse dirt can impair the proper functioning of the seat belt buckle.

Clean the seat belt (while it remains fitted in the machine) with a mild soap solution only. Do not use chemical agents as they can destroy the fabric.

## **Cleaning in a saline environment**

1. Park the machine in a wash bay or place.
2. See "**Preparing lubrication**".
3. Check the machine for salt deposits or corrosion. Have corrosion removed by a Wacker Neuson service center.
4. Clean the machine with a high-pressure cleaner. Clean the machine ensuring that there are no salt deposits in places that are difficult to access.  
Bear in mind the information on cleaning and maintenance.
5. Lubricate the machine according to the lubrication plan.
6. Allow the machine to dry and check it again for salt deposits.

## **Loose threaded fittings and attachments**

Contact a Wacker Neuson service center.

### 7.6 Lubrication work

– see chapter “Preparing lubrication” on page 7-8

### 7.7 Fuel system

#### Important information regarding the fuel system

---

**i** **Information**

In order to prevent wet stack, fill up the fuel tank completely at the end of each workday.

---

**i** **Information**

Do not run the fuel tank completely dry. Otherwise, air is drawn into the fuel system. This requires bleeding the fuel system.

---

#### Diesel fuel specification

---

**NOTICE**

Engine damage due to incorrect or dirty diesel fuel.

- ▶ Only use clean diesel fuel according to the **fluids and lubricants** list.
  - ▶ Do not use any diesel fuel with additives.
-

## Refueling

---

 **WARNING****Explosion hazard due to flammable fuel/air mixtures!**

Fuels develop explosive and flammable mixtures with air that can cause serious burns or death.

- ▶ Fire, open flames and smoking is prohibited.
  - ▶ Open tank lock carefully to release the pressure in the fuel tank.
  - ▶ Keep the maintenance area clean.
  - ▶ Do not refuel in closed rooms.
  - ▶ Do not add gasoline to diesel fuel.
  - ▶ Let the engine cool down.
- 

 **CAUTION****Health hazard due to diesel fuel!**

Diesel fuel and fuel vapors are harmful to health!

- ▶ Avoid contact with the skin, eyes and mouth.
  - ▶ Seek medical attention immediately in case of accidents with diesel fuel.
  - ▶ Wear protective equipment.
- 

 **CAUTION****Fire hazard due to diesel fuel!**

Diesel fuel gives off flammable vapors. This can cause injury.

- ▶ Fire, open flames and smoking is prohibited.
  - ▶ Do not add gasoline to diesel fuel.
- 

**NOTICE**

Do not refuel with cans in order to avoid dirt in the fuel.

---

**Environment**

Use a suitable container to collect fluids and lubricants as they flow out and dispose of them in an environmentally friendly manner.

---

## Refueling

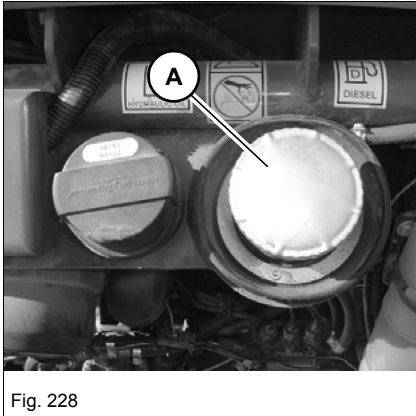


Fig. 228

The filler neck of the fuel tank is located in the engine compartment.

1. Stop and park the machine. Stop the engine. See “Preparing lubrication”.
2. Open the engine cover.
3. Open tank lock **A** carefully to release the pressure in the fuel tank.
4. Refuel the machine.
5. Close the filler cap.

### Stationary fuel pumps

Even the smallest particles of dirt can cause increased engine wear, malfunctions in the fuel system and reduced effectiveness of the fuel filters.

### Refueling from barrels

If refueling from barrels cannot be avoided, note the following points:

- Barrels must neither be rolled nor tilted before refueling.
- Protect the suction pipe opening of the barrel pump with a fine-mesh screen.
- Immerse the suction pipe opening down to a max. 15 cm (6 in) above the bottom of the barrel.
- Only fill the tank using refueling aids (funnels or filler pipes) with an integral microfilter.
- Keep all refueling containers clean.

## Checking the water separator

The water separator is located in the engine compartment.

### Water separator

Empty the water separator if the red indicator ring **A** rises to position **B**.

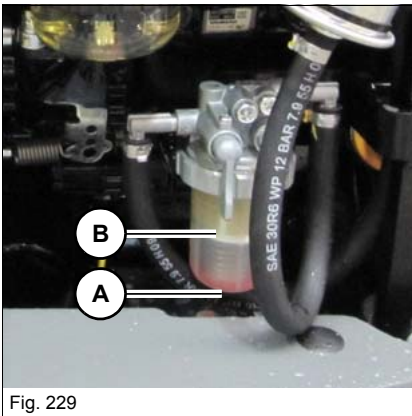


Fig. 229

## Emptying the water separator

### **i** Information

The fuel system can be bled automatically even if the engine is at operating temperature

– see chapter “*Bleeding the fuel system*” on page 7-28.

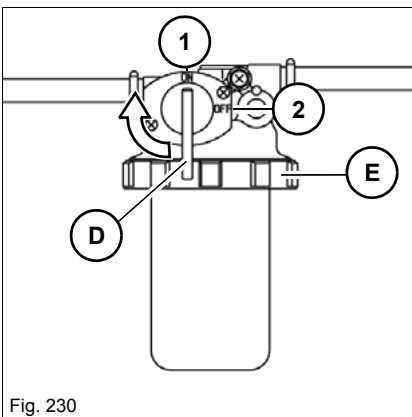


Fig. 230

1. Stop and park the machine. Stop the engine. See “Preparing lubrication”.
2. Prepare a suitable container for collecting the fuel/water mixture.
3. Open the engine cover.
4. Rotate the ball valve **D** in position **2**.
  - ➔ Fuel supply is interrupted.
5. Unscrew threaded ring **E**.
6. Collect the fuel/water mixture in a suitable container.
7. Screw on the thread ring **E**.
  - ➔ The indicator ring is at the base of the water separator.
8. Rotate the ball valve **D** in position **1**.
  - ➔ Fuel supply is open.
9. Close and lock the engine cover.

### Bleeding the fuel system

Bleed the fuel system in the following cases:

- After removing and fitting the fuel filter, prefilter or the fuel lines back on again.
- If the fuel tank is run empty.
- If the machine is put into operation after having been out of operation for more than 30 days.

#### **Bleed:**

1. Raise the control lever base.
2. Remove the starting key and carry it with you.
3. Fill up and close the fuel tank.
4. Turn the starting key to the first position.
5. Wait about 5 minutes while the fuel system bleeds itself automatically.
6. Start the engine.

If the engine runs smoothly for a while and then stops, or if it does not run smoothly:

1. Stop the engine.
2. Raise the control lever base.
3. Remove the starting key and carry it with you.
4. Bleed the fuel system again as described above.
5. Check for leaks after starting the engine.
6. Have a Wacker Neuson service center perform a check if necessary.



## 7.8 Engine lubrication system

### Important information regarding the engine lubrication system

---

**NOTICE**

Possible engine damage due to incorrect engine oil level.

- ▶ The oil level must be between the MIN and MAX marks.
- 

**NOTICE**

Damage due to wrong engine oil.

- ▶ Use engine oil according to **Fluids and lubricants** list.
  - ▶ Have the oil changed only by a Wacker Neuson service center.
- 

**NOTICE**

Damage due to adding engine oil too quickly.

- ▶ Add the engine oil slowly so it can go down without entering the intake system.
- 

**Information**

Check the oil level once a day. Wacker Neuson recommends checking before starting the engine. Check the oil level not less than five minutes after stopping the engine.

---

## Checking the engine oil level

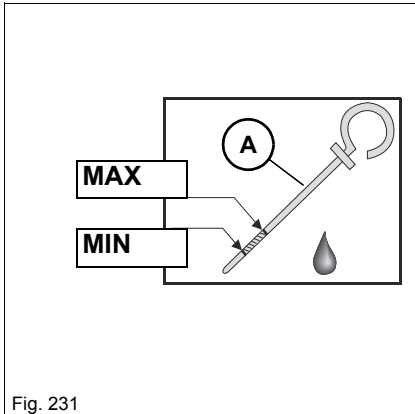


Fig. 231

1. Stop and park the machine. Stop the engine. See "Preparing lubrication".
2. Open the engine cover.
3. Wipe the area around oil-level dipstick with a lint-free cloth.
4. Pull out oil-level dipstick **A** and wipe it with a lint-free cloth.
5. Slide in oil dipstick **A** completely.
6. Withdraw it and read off the oil level.
  - The oil level must be between the MIN and MAX marks.
  - Add engine oil if necessary.
7. Slide in oil dipstick **A** completely.
8. Close and lock the engine cover.

## Filling up engine oil

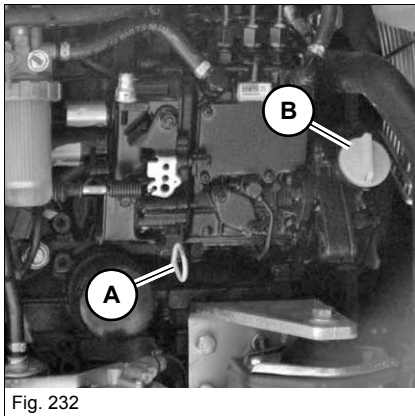


Fig. 232

1. Stop and park the machine. Stop the engine. See "Preparing lubrication".
2. Open the engine cover.
3. Open filler cap **B**.
4. Raise oil dipstick **A** slightly to allow any trapped air to escape.
5. Add engine oil.
6. Wait at least five minutes until all the oil has run into the oil sump.
7. Check the oil level.
8. Add oil if necessary and check the oil level again.
9. Close filler cap **B**.
10. Slide in oil dipstick **A** completely.



### Environment

Use a suitable container to collect fluids and lubricants as they flow out and dispose of them in an environmentally friendly manner.

## 7.9 Cooling system

### Important information regarding the cooling system

The radiator is located on the right in the engine compartment.

---

 **WARNING****Poisoning hazard due to hazardous substances!**

Contact with hazardous substances can cause serious injury or death.

- ▶ Wear protective equipment.
- ▶ Do not inhale or swallow coolant.
- ▶ Avoid contact of the coolant or antifreeze with the skin and eyes.

---

 **WARNING****Burn hazard due to coolant or antifreeze!**

The coolant and antifreeze are easily flammable fluids that can cause serious burns or death if they are brought into contact with fire or open flames.

- ▶ Wear protective equipment.
- ▶ Only perform maintenance on an engine that has cooled down.
- ▶ Fire, open flames and smoking is prohibited.

---

 **WARNING****Burn hazard due to hot coolant!**

At high temperatures, the cooling system is under pressure and can cause burning of the skin.

- ▶ Wear protective equipment.
- ▶ Let the engine cool down.
- ▶ Carefully open the radiator cap.

---

**NOTICE**

Possible engine damage due to wrong coolant.

- ▶ Observe the engine/vehicle fluid table or coolant compound table.

---

**NOTICE**

Possible engine damage due to low coolant level.

- ▶ Check the coolant level once a day.
-

## Checking the coolant level

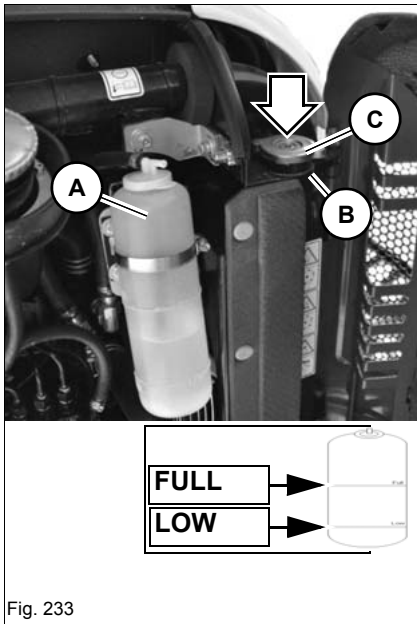


Fig. 233

## Adding coolant

1. Stop and park the machine. Stop the engine. See "Preparing lubrication".
2. Carefully unscrew filler cap **C** and release the pressure.
3. Perform a visual inspection of the water cooler **B**.
4. If the coolant level is below the marking **LOW** of the compensation container **A** or the coolant does not reach to the filler neck of the water cooler **B**:
  - Add coolant.



### Information

Check the coolant level once a day before starting the engine.  
Observe the coolant compound table

1. Stop and park the machine. Stop the engine. See "Preparing lubrication".
2. Carefully unscrew filler cap **C** and release the pressure.
3. Open filler cap **C**.
4. Top off coolant up to the lower edge of the filler neck.
5. Close filler cap **C**.
6. Start the engine and let it warm up for about 5 – 10 minutes.
7. Stop the engine.
8. Remove the starting key and carry it with you.
9. Let the engine cool down.
10. Check the coolant level again.
  - The coolant level must be between the **LOW** and **FULL** marks.
11. If necessary, add coolant and repeat the procedure until the coolant level remains constant.
12. Close and lock the engine cover.

## Cleaning the radiator

---

 **CAUTION****Burn hazard due to hot surfaces!**

Hot radiators can cause burns.

- ▶ Stop the engine and let it cool down.
  - ▶ Wear protective equipment.
- 

**NOTICE**

Damage to diesel engine and hydraulic system due to dirt on the radiator.

- ▶ Check and if necessary clean the radiator once a day.
  - ▶ In dusty or dirty work conditions, clean more frequently than indicated in the maintenance plan.
- 

**NOTICE**

Damage to radiator fins during cleaning.

- ▶ Keep a safe distance from the radiator during cleaning.
  - ▶ Use oil-free compressed air (2 bar/29 psi max.) to clean.
- 

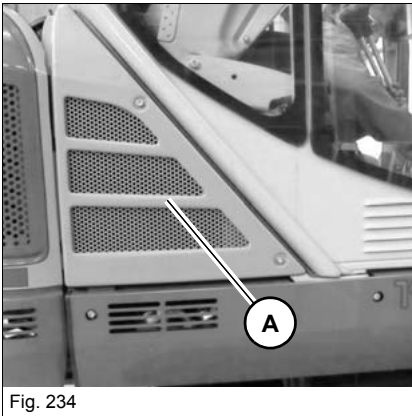


Fig. 234

The radiators are located under the right side cover **A**.

1. Stop and park the machine. Stop the engine. See "Preparing lubrication".
2. Remove the right side cover **A**.
3. Remove dust and other foreign bodies from the fins with compressed air.
4. Attach the right side cover **A**.

## 7.10 Air filter

### Important information regarding the air filter

- The air filter is composed of an interior and exterior filter.
- Store the air filter in its original packaging and dry.
- Check air filter, air filter attachments and air intake hoses for damage, and immediately repair or replace if necessary.
- Check the screws at the induction manifold and the clamps for tightness.

### Dirt indicator

#### **NOTICE**

Damage to diesel engine due to dirty air filter.

- ▶ Do not clean the air filter, but rather have them replaced.
- ▶ Do not use any damaged air filter elements.

The air cleaner must be changed if the yellow mark **B** on the soiling display **A** reaches the red service display **C**.

- After changing the air cleaner elements, press the knob **D** in order to reset the yellow mark **B**.

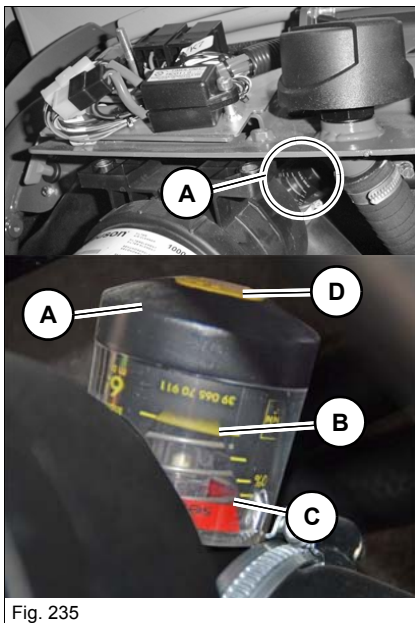
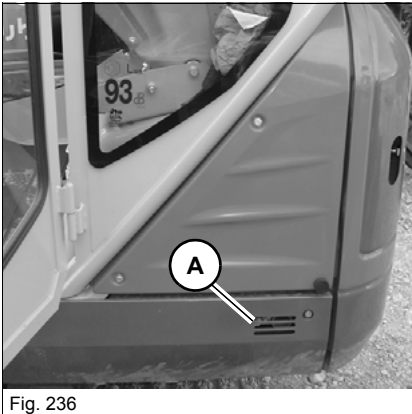


Fig. 235

### Replacing the air filter

Have maintenance performed only by a Wacker Neuson service center.

## Checking the air intake



---

### **NOTICE**

Possible engine damage due to intake of dirty air.

- ▶ Check once a day for cleanliness before putting the machine into operation.

- 
1. Stop and park the machine. Stop the engine. See "Preparing lubrication".
  2. Remove the starting key and carry it with you.
  3. Check and if necessary clean ventilation grill **A**.

## 7.11 V-belt

### **WARNING**

#### **Injury hazard due to rotating parts!**

Rotating parts can cause serious injury or death.

- ▶ Open the engine cover only at engine standstill.
- ▶ Remove the starting key and carry it with you.

### **CAUTION**

#### **Burn hazard due to hot surfaces!**

Can cause serious burns.

- ▶ Stop the engine and let hot surfaces cool down.
- ▶ Wear protective equipment.

### **CAUTION**

#### **Injury hazard due to open maintenance access!**

Can cause injury.

Take care to avoid injuries when the maintenance access door is open.

## Checking V-belt tension

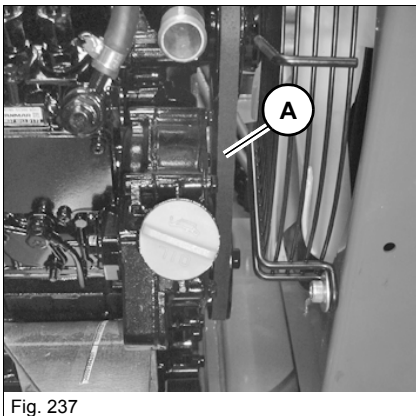


Fig. 237

1. Stop and park the machine. Stop the engine. See "Preparing lubrication".
2. Raise the control lever base.
3. Remove the starting key and carry it with you.
4. Let the engine cool down.
5. Open the engine cover.
6. Carefully check the V-belt **A** for damage.
7. Press with your thumb about 100 N (22.5 lbs.) to check the deflection of the V-belt between the crankshaft disk and the fan wheel. The deflection should be between 7 and 9 mm (0.27 and 0.35 in).
8. Contact an authorized service center in the following cases:
  - Damaged V-belt
  - V-belt is touching the keyway base
  - Damaged pulleys
  - V-belt tension too low

## Retension the V-belt

The V-belt may only be re-tensioned by an authorized service center.



## 7.12 Hydraulic system

### Important information on the hydraulic system

---

 **WARNING****Burn hazard due to hot hydraulic oil!**

Hot hydraulic oil can cause burning to the skin, serious injury or death.

- ▶ Release the pressure in the hydraulic system.
  - ▶ Let the engine cool down.
  - ▶ Wear protective equipment.
- 

 **WARNING****Injury hazard due to fluid escaping under pressure!**

Hydraulic oil escaping under pressure can penetrate the skin and cause serious injury or death.

- ▶ Do not operate the machine with leaking or damaged hydraulic system components.
  - ▶ Open the breather filter carefully to slowly release the pressure inside the reservoir.
  - ▶ Wear protective equipment. If oil contacts the eye flush immediately with clean water and seek medical treatment.
  - ▶ Malfunctioning or leaking threaded fittings, hose connections and pressure lines must be immediately repaired by a Wacker Neuson service center. Search for hydraulic leaks with a piece of cardboard.
  - ▶ Always consult a doctor immediately, even if the wound seems insignificant. Hydraulic oil causes blood poisoning.
- 

**NOTICE**

Damage due to wrong hydraulic oil.

- ▶ Only use hydraulic oil according to the **fluids and lubricants** list.
  - ▶ Have the hydraulic oil only changed by an authorised service centre.
- 

**NOTICE**

Damage to hydraulic system due to incorrect hydraulic oil level.

- ▶ With a warm engine, the hydraulic oil must be about at the middle of the sight glass.
  - ▶ Check the hydraulic oil level once a day.
-

**NOTICE**

Damage to hydraulic system due to dirty hydraulic oil.

- ▶ Always add hydraulic oil using the filling screen.
- ▶ If the hydraulic oil in the sight glass is cloudy, this indicates that water or air has penetrated the hydraulic system. Contact a Wacker Neuson service center.
- ▶ Contact a Wacker Neuson service center if the filter of the hydraulic system is dirty.

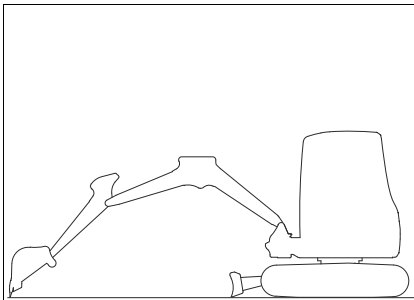
**Checking the hydraulic oil level**

Fig. 238

1. Park the vehicle on firm, level, and horizontal ground.
2. Position the boom straight ahead at the center of the machine (see figure).
3. Lower the boom and the stabilizer blade to the ground.
4. Stop the engine.
5. Operate the control lever repeatedly to release the pressure in the hydraulic system.
6. Remove the starting key and carry it with you.

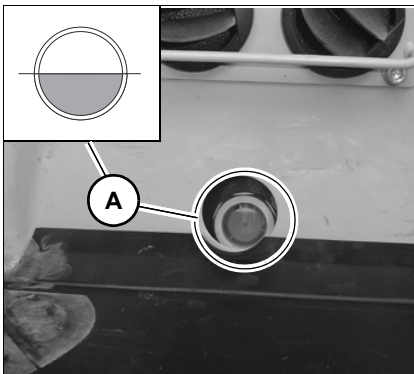


Fig. 239

7. The inspection glass **A** is located on the seat console.
8. Check the oil level on sight glass **A**.
  - ▶ If the engine is warm, the oil level must be approximately at the middle of sight glass **A**.
9. Add hydraulic oil if the oil level is below this mark.

## Adding hydraulic oil

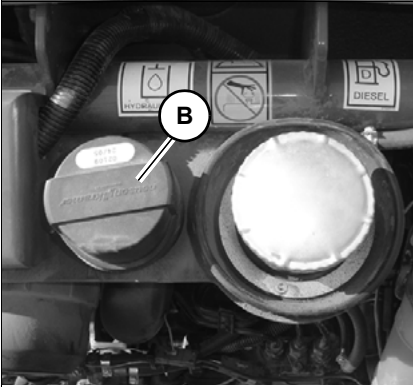


Fig. 240

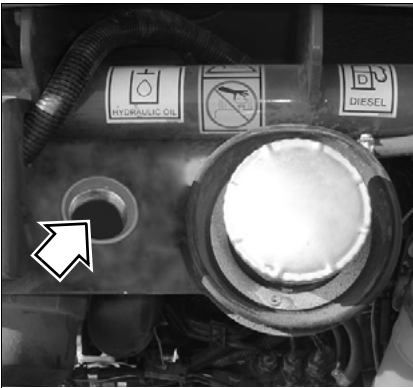


Fig. 241

1. Open the engine cover.
2. Open air cleaner **C** slowly to release the pressure inside the hydraulic oil tank.
3. Remove the air cleaner **B**.
4. Add hydraulic oil up to the corresponding mark.
5. Check the hydraulic oil level on sight glass **A**.
6. Add if necessary and check again.
7. Screw in the air cleaner **B** tightly.
8. Close and lock the engine cover.



### **Environment**

Use a suitable container to collect fluids and lubricants as they flow out and dispose of them in an environmentally friendly manner.

### Checking the hydraulic system for leaks and general condition

Check the hydraulic system and hoses daily for leaks and general condition.

---

#### **Information**

Leaks and damaged pressure lines must be immediately repaired or replaced by an authorised service centre. This not only increases the operating safety of the machine but also helps to protect the environment.

- ▶ Have damaged or leaky pressure lines immediately repaired or replaced by a Wacker Neuson service center.
- ▶ Have hydraulic hoses replaced every 6 years from the date of manufacture, even if they do not seem to be damaged.

---

In this respect, Wacker Neuson recommends that you observe all the relevant safety regulations for hydraulic lines, as well as the safety regulations regarding accident prevention and occupational medicine in your country. Also observe DIN 20 066, TI. 5.

The article number is on the clamping section of each hose connection.

The date of manufacture is indicated on each flexible line.

Have the respective line replaced immediately if one of the following problems is detected:

- Damaged or leaky hydraulic seals.
- Worn or torn shells or uncovered reinforcement branches.
- Expanded shells in several positions.
- Entangled or crushed movable parts.
- Foreign bodies jammed or stuck in protective layers.

## 7.13 Electrical system

### Important information regarding the electrical system

Maintenance and repair work on the electrical system may be performed only by a Wacker Neuson service center!

- Malfunctioning components of the electrical system must be replaced by a Wacker Neuson service center.
- Light bulbs and fuses may be replaced by the operator.

#### Alternator

- Contact a Wacker Neuson service center if the alternator charge indicator light is malfunctioning.
- 



#### **WARNING**

##### **Injury hazard due to malfunctioning batteries!**

Batteries give off explosive gases that can cause deflagrations if ignited.

- ▶ Wear protective equipment.
  - ▶ Fire, open flames and smoking is prohibited.
  - ▶ Do not jump start the engine if the battery is malfunctioning or frozen, or if the acid level is too low.
  - ▶ Do not place conductive articles on the battery – risk of short circuit.
- 

#### **NOTICE**

Possible damage to electrical components or engine electronics.

- ▶ Do not place tools or other conductive articles on the battery – risk of short circuit.
  - ▶ Do not interrupt voltage-carrying circuits at the battery terminals because of the sparking hazard.
  - ▶ Do not disconnect the battery while the engine is running.
- 



#### **Environment**

Dispose of old batteries in an environmentally friendly manner.

---

### Fuses and relays

- Blown fuses indicate overloading or short circuits. Have the electrical system checked by a Wacker Neuson service center.
- Only use fuses with the specified amperage.
  - see chapter “Main fuse box” on page 9-5
  - see chapter “Cabin fuse box” on page 9-6

### Battery

The battery may be checked, disconnected, charged and replaced only by a Wacker Neuson service center.

### 7.14 Heating, ventilation and air conditioning system

Not available.

### 7.15 Washer system

Only use glass cleaner (with antifreeze if necessary) for refilling.

### 7.16 Axles/travelling drive

Have maintenance performed only by a Wacker Neuson service center.

### 7.17 Braking system

Have maintenance performed only by a Wacker Neuson service center.

## 7.18 Tracks

### Checking track tension

#### **WARNING**

##### **Crushing hazard during work under the machine!**

Working under the tracks can cause serious injury or death.

- ▶ Do not allow anyone to stay in the danger zone.

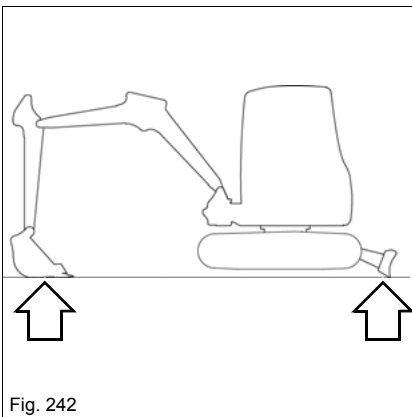


Fig. 242

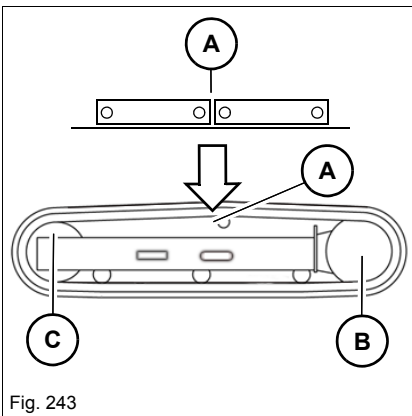


Fig. 243

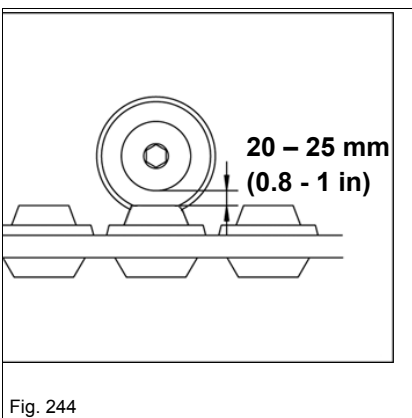


Fig. 244

1. Park the vehicle on firm, level, and horizontal ground.
2. Raise the machine evenly and horizontally by means of the boom and stabilizer blade.
3. Place the tracks so that mark **A** is in the middle between drive pinion **B** and track tension roller **C**.
4. Stop the engine.
5. Operate the control lever repeatedly to release the pressure in the hydraulic system.
6. Raise the control lever base.
7. Remove the starting key and carry it with you.
8. Adjust the correct track tension if the play between the track roller and the track is not 20 – 25 mm (0.8 – 1 in).



### Correcting track tension

---

 **WARNING**

**Injury hazard due to grease escaping under pressure!**

Grease escaping under pressure can penetrate the skin and cause serious injury or death.

- ▶ Open the lubricating valve only very carefully and do not unscrew it more than one revolution.
  - ▶ Wear protective equipment.
  - ▶ Contact a Wacker Neuson service center if you are unable to reduce the track tension.
- 

**NOTICE**

Possible damage to cylinders and tracks due to overtightening.

- ▶ Tighten the tracks only up to the mandatory measuring distance.
-



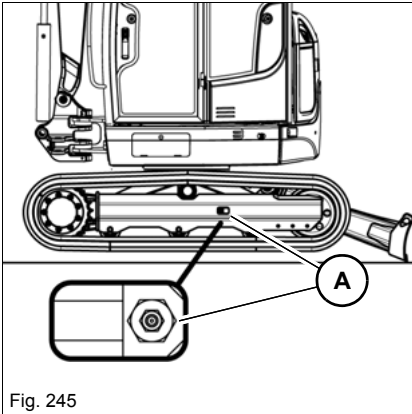


Fig. 245

### Tightening the tracks

1. Park the vehicle on firm, level, and horizontal ground.
2. Raise the machine evenly and horizontally by means of the boom and stabilizer blade.
3. Stop the engine.
4. Operate the control lever repeatedly to release the pressure in the hydraulic system.
5. Pump grease with a grease gun through lubricating valve **A**.
6. Start the engine.
7. Lower the machine to the ground.
8. In order to check that the tension is correct:
  - Let it run at idling speed without any load
  - Slowly move the machine forward and reverse and switch it off again.
9. Check the track tension again.
  - ➔ If it is not correct:
10. Repeat steps 2 – 9. Contact a Wacker Neuson service center if track tension still is too low after pumping in more grease.

### Reducing tension

1. Place a suitable container underneath to collect the grease.
2. Slowly turn the lubricating valve **A** a maximum of one revolution counterclockwise to release the grease.
  - ➔ The grease flows out of the groove of the lubricating valve.
3. Retighten lubricating valve **A**.
4. In order to check that the tension is correct:
  - Lower the machine to the ground,
  - Start the engine,
  - Let it run at idling speed without any load, then slowly move the machine forward and reverse, then turn it off again. Raise the machine again by means of the boom and stabilizer blade.
5. Check the track tension again.
  - ➔ If it is not correct:
6. Adjust again.

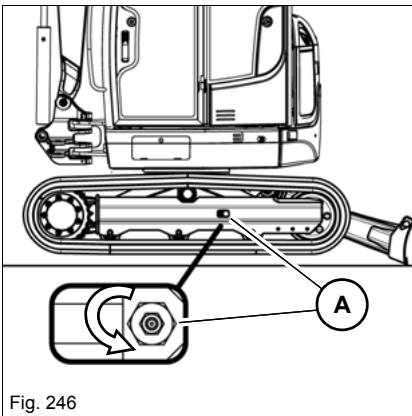


Fig. 246



### Environment

Use a suitable container to collect fluids and lubricants as they flow out and dispose of them in an environmentally friendly manner.

### 7.19 Maintenance of attachments

#### Important information regarding maintenance of attachments

Correct maintenance and service is absolutely necessary for smooth and continuous operation, and for an increased service life of the attachments. Please observe the lubrication and maintenance instructions in the Operator's Manuals of the attachments.

### 7.20 Maintenance of options

Have a Wacker Neuson service center check all eyes regularly:

- Machine lifting eyes
- Attachment lifting eyes
- Attachment load hooks
- Tie-down points
- Towing eyes

Have eyes or load hooks with inadmissible wear, a defective spring mechanism, etc. immediately replaced by a Wacker Neuson service center.

### 7.21 Exhaust gas treatment

Not available

### 7.22 Machine preservation

Machines are partly preserved at the factory (for example in the engine compartment). Operation in an aggressive environment (for example salt deposits) is prohibited.

## 8 Malfuctions

### Information

Contact a Wacker Neuson service center in case of malfuctions or signs that are not listed in the following tables or that cannot be rectified with specified measures.

### 8.1 Diesel engine malfuctions

Malfuction/sign	Possible cause	Remedy	Page
Engine does not start or is not easy to start	Empty fuel tank	Refueling	<a href="#">7-26</a>
	Malfuctioning or empty battery	Have the battery replaced by an authorized service center	--
	Malfuctioning fuse	Check the fuse	<a href="#">9-5</a>
	Control lever base not raised	Raise the control lever base	<a href="#">4-35</a>
Engine starts, but does not run smoothly or faultless	Air in fuel system	Let the engine run	<a href="#">7-28</a>
	Water in fuel system	Empty the water separator	<a href="#">7-27</a>
Engine overheats	Engine oil level too low	Adding engine oil	<a href="#">7-30</a>
	Dirty air filter	Contact a Wacker Neuson service center	<a href="#">7-34</a>
	Dirty radiator fins	Cleaning the radiator	<a href="#">7-33</a>
	Coolant level too low	Adding coolant	<a href="#">7-32</a>
	Malfuctioning or insufficiently tightened V-belt	Contact a Wacker Neuson service center	--
Engine does not have enough output	Dirty air filter	Contact a Wacker Neuson service center	<a href="#">7-34</a>
Insufficient or no engine oil pressure	Engine oil level too low	Adding engine oil	<a href="#">7-30</a>
Black engine smoke	Dirty air filter	Contact a Wacker Neuson service center	<a href="#">7-34</a>
Blue engine smoke	Oil level too high	Contact a Wacker Neuson service center	--
The indicator light for the coolant temperature illuminates (red) and the buzzer sounds	The coolant temperature is too high	Let the engine run at idling speed without any load Wait until the temperature drops and the indicator light goes out Stop the engine Checking the coolant level	<a href="#">4-29</a> , See also page <a href="#">8-3</a>







## 8.2 Malfunctions of the travelling drive

Malfunction/sign	Possible cause	Remedy	See
Machine does not stay on track, machine pulls to the right or left	Wrong track tension	Tighten tracks correctly	<a href="#">7-44</a>
	Foreign bodies (stones, for example) stuck in tracks	Remove foreign bodies	--
	Uneven wear of tracks	Contact a service center	--

## 8.3 Malfunctions of the hydraulic system

Malfunction/sign	Possible cause	Remedy	See
Hydraulic system overheats	Dirty hydraulic oil radiator	Clean the hydraulic oil radiator	<a href="#">7-33</a>
	Hydraulic oil level too low	Adding hydraulic oil	<a href="#">7-39</a>
	Malfunctioning or insufficiently tightened V-belt	Contact a service center	--
The display element emits a continuous buzzing sound	Malfunctioning pressure switch of safe load indicator	Stop machine operation immediately, have the error repaired by a Wacker Neuson service center	--
Controls have no function	Control lever base raised	Lower the control lever base	<a href="#">4-35</a>
	Malfunctioning fuse	Check the fuse	<a href="#">9-5</a>
Upper carriage cannot be swivelled	Upper carriage locked	Remove the pin	<a href="#">6-8</a>

## 8.4 Malfuctions of the electrical system

Malfuction/sign	Indicator light	Possible cause	Remedy	See
The switch-over of the speeds is not working.		Malfunctioning fuse	Check the fuse	9-5
Working light or horn does not work.	--	Malfunctioning fuse	Check the fuse	9-5
Charge indicator light (red) does not go out when the engine runs		Malfunctioning battery Malfunctioning alternator	Stop machine operation immediately Have the error repaired by a Wacker Neuson service center	--
Preheating indicator light (yellow) remains illuminated when the engine runs		Malfunctioning starter Malfunctioning display element		--
Indicator light for engine oil pressure (red) illuminates and the buzzer sounds when the engine runs		Pressure drop in engine oil circuit		
The indicator light for the coolant temperature (red) illuminates and the buzzer sounds		Coolant temperature is too high	Let the engine run at idling speed without any load Wait until the temperature drops and the indicator light goes out Stop the engine. Checking the coolant level	4-29
The indicator light for the engine oil pressure (red) and/or the charge indicator light (red) do not illuminate when the engine stops and the starter is switched on (position 1).		Malfunctioning indicator light	Stop machine operation immediately Have the control lamp replaced by an authorized service center	

## 8.5 Malfuctions in the air conditioning system

No malfuctions specified.

## 8.6 Disorders of attachments

No malfuctions specified.



Notes:

## 9 Technical data

### 9.1 Models and trade names

– see chapter “ Overview of models and trade name” on page 3-2

### 9.2 Engine

Engine	ET16
Product	Yanmar
Type	3TNV76-SNS2
Design	Water-cooled 3-cylinder diesel engine
Intake system	Naturally aspirated engine
fuel injection system	Indirect
Engine management	Mechanical
Displacement	1116 cm <sup>3</sup> (68 cu. in.)
Nominal bore and stroke	76 x 82 mm (2.9 x 3.2 in)
Power	13.2 kW at 2,200 rpm (17.7 hp at 2,200 rpm)
Max. torque	65.8 Nm at 1600 rpm (48.5 ft./lbs. at 2,200 rpm)
Max. engine speed without load	2,375 +/-25 rpm (2,375 +/-25 rpm)
Idling speed	1,300 +/-50 rpm (1,300 +/-50 rpm)
Starting aid	Glow plug (preheating time 4 seconds)
Exhaust values according to	EPA – Tier IV final (up to 2012)



Engine	ET16
Product	Yanmar
Type	3TNV80F-SSNS2
Design	Water-cooled 3-cylinder diesel engine
Intake system	Naturally aspirated engine
fuel injection system	Indirect
Engine management	Mechanical
Displacement	1,266 cm <sup>3</sup> (77 in <sup>3</sup> )
Nominal bore and stroke	80 x 84 mm (3.1 x 3.3 in)
Power	13.2 kW at 2200 rpm (17.7 hp at 2,200 rpm)
Max. torque	65.8 Nm at 1600 rpm (48.5 ft/lbs at 2,200 rpm)
Max. engine speed without load	2375 +/- 25 rpm (2,375 +/- 25 rpm)
Idling speed	1300 +/- 50 rpm (1,300 +/- 50 rpm)
Starting aid	Glow plug (preheating time 4 seconds)
Exhaust values according to	EPA – Tier IV final (from 2012)



### Information

The machine has about 17 % less output at altitudes over 800 m (2625 ft) above sea level. However, this does not affect excavator operation (Yanmar 3TNV80F-SSNS2).



### 9.3 Traveling drive/axles

	<b>ET16</b>
Travelling drive	Axial piston motor

### 9.4 Brake

See drive lever

### 9.5 Tracks

Type	Width mm (in)	Ground pres- sure kg/cm <sup>2</sup> (lbs/in <sup>2</sup> )	Ground clear- ance mm (in)
Rubber	230 (9)	0.26 (3.7)	180 (7)

### 9.6 Steering system

See drive lever

### 9.7 Operating hydraulics

Work hydraulics	<b>ET16</b>
Type of control	Load-pressure independent flow distribution (LIFD)
Number/type of pumps	1
Flow rate	33.3 l/min (8.8 gal/min)
Operating pressure for operating and travel hydraulics	200 bar (2,901 psi)
Swivel unit operating pressure	130 bar (1,886 psi)
Hydraulic reservoir capacity	20 l (5.3 gal)
Hydraulic oil quantity (system fill)	35 liters (9.2 gal)
Swivel range of upper carriage	360°
Rotation speed of upper carriage	9 rpm

### Maximum speed

	<b>ET16</b>
Speed range 1	2.4 kph (1.5 mph)
Speed range 2	4.1 km/h (2.6 mph)

## 9.8 Electrical system

### **WARNING**

**Fire hazard in case of incorrect handling of electric components!**

Can cause serious injury or death.

- ▶ Use only specified fuses.
- ▶ Do not repair or bypass fuses.
- ▶ If a replaced fuse is blown again directly, do not put the machine into operation and contact a Wacker Neuson service center.

### **NOTICE**

Explosion hazard in case of incorrect handling of fuses.

- ▶ Use only specified fuses.
- ▶ Do not repair or bypass fuses.
- ▶ If a replaced fuse is blown again directly, do not put the machine into operation and contact a Wacker Neuson service center.

## Electrical components

	<b>ET16</b>
Alternator	12 V 40 A
Starter	12 V 1.1 kW (1.5 hp)
Battery	12 V 44 Ah

**Main fuse box**

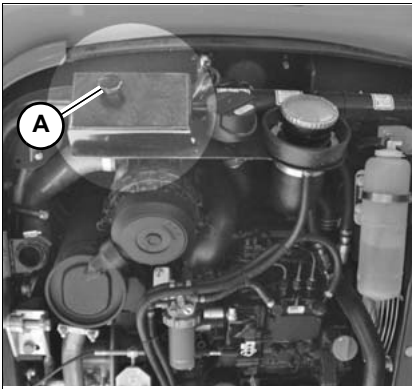


Fig. 247

The main fuses and the relay are located in the engine compartment.

Remove the screw **A** and remove the battery cover.

Fuses/relays	ET16
F1	Main fuse 40 A; air-pressure sensor/output adaptation (Yanmar 3TNV80F-SSNS2)
K6	Preheating time lag relay
K7	Start switching relay
K8	Time lag relay 1s cut-off solenoid
K9	Cut-off solenoid switching relay

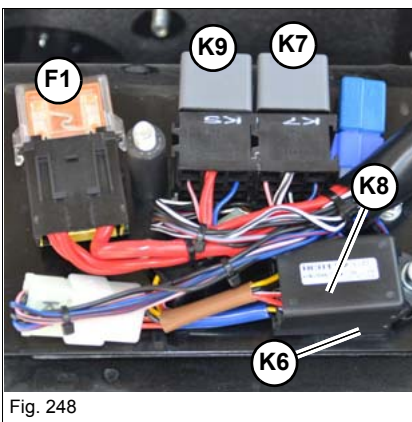


Fig. 248

### Cabin fuse box



Fig. 249

The cabin fuse box is located on the seat console.

F2	10A	
F3	10A	
F4	15A	
F5	10A	
F6	15A	
F7	10A	
F8	10A	
F9	15A	

Fig. 250

Fuse	Ampere	ET16
F2	10A	Relay, display, cutoff solenoid
F3	10A	Boom light
F4	15A	Roof light
F5	10A	Valves, horn, driving signal, speed 2
F6	15A	Heating
F7	10A	Wiper, interior light
F8	10A	Rotating beacon, radio, immobilizer
F9	15A	Sockets

### Bulbs

	ET16
Working lights	Halogen lamp 12 V 55 W H3
Interior light	Double-ended tubular lamp 12 V-5 W

## 9.9 Tightening torques

### General tightening torques

Property class	8.8	10.9	12.9	8.8	10.9
Screw dimensions	Screws according to DIN 912, DIN 931, DIN 933, etc.			Screws according to DIN 7984	
	Nm (ft.lbs.)	Nm (ft.lbs.)	Nm (ft.lbs.)	Nm (ft.lbs.)	Nm (ft.lbs.)
M5	5.5 (4)	8 (6)	10 (7)	5 (4)	7 (5)
M6	10 (7)	14 (10)	17 (13)	8.5 (6)	12 (9)
M8	25 (18)	35 (26)	42 (31)	20 (15)	30 (22)
M10	45 (33)	65 (48)	80 (59)	40 (30)	59 (44)
M12	87 (64)	110 (81)	147 (108)	69 (51)	100 (74)
M14	135 (100)	180 (133)	230 (170)	110 (81)	160 (118)
M16	210 (155)	275 (203)	350 (258)	170 (125)	250 (184)
M18	280 (207)	410 (302)	480 (354)	245 (181)	345 (254)
M20	410 (302)	570 (420)	690 (509)	340 (251)	490 (361)
M22	550 (406)	780 (575)	930 (686)	460 (339)	660 (487)
M24	710 (524)	1000 (738)	1190 (878)	590 (435)	840 (620)
M27	1040 (767)	1480 (1,092)	1770 (1,305)	870 (642)	1250 (922)
M30	1420 (1,047)	2010 (1,482)	2400 (1,770)	1200 (885)	1700 (1,254)

Tightening torques/fine-pitch thread					
Property class	8.8	10.9	12.9	8.8	10.9
Screw dimensions	Screws according to DIN 912, DIN 931, DIN 933, etc.			Screws according to DIN 7984	
	Nm (ft.lbs.)	Nm (ft.lbs.)	Nm (ft.lbs.)	Nm (ft.lbs.)	Nm (ft.lbs.)
M8X1.0	25 (18)	37 (28)	43 (32)	22 (16)	32 (24)
M10X1.0	50 (37)	75 (55)	88 (65)	43 (32)	65 (48)
M10X1.25	49 (36)	71 (52)	83 (61)	42 (31)	62 (46)
M12X1.25	87 (64)	130 (96)	150 (111)	75 (55)	110 (81)
M12X1.5	83 (61)	125 (92)	145 (107)	72 (53)	105 (77)
M14X1.5	135 (100)	200 (148)	235 (173)	120 (89)	175 (129)
M16X1.5	210 (155)	310 (229)	360 (266)	180 (133)	265 (195)
M18X1.5	315 (232)	450 (332)	530 (391)	270 (199)	385 (284)
M20X1.5	440 (325)	630 (465)	730 (538)	375 (277)	530 (391)
M22X1.5	590 (435)	840 (620)	980 (723)	500 (369)	710 (524)
M24X2.0	740 (546)	1070 (789)	1250 (922)	630 (465)	900 (664)
M27X2.0	1100 (811)	1550 (1,143)	1800 (1,328)	920 (679)	1300 (959)
M30X2.0	1500 (1,106)	2150 (1,586)	2500 (1,844)	1300 (959)	1850 (1,364)

## 9.10 Coolant Compound table

Outside temperature <sup>1</sup>	Distilled water	Coolant <sup>2</sup>
Up to °C (°F)	% by volume	% by volume
-37 (-34.6)	50	50

1. Use the 1:1 concentration for warm outside temperatures, too, to ensure protection against corrosion, cavitation, and deposits.
2. Do not mix the coolant with other coolants.

## 9.11 Noise emissions

	ET16 (Yanmar 3TNV76-SNS2)
Measured sound power level L <sub>WA</sub> <sup>1</sup>	93.0 dB(A)
Guaranteed sound power level L <sub>WA</sub> <sup>1</sup>	93.0 dB(A)
Uncertainty factor K <sub>A2</sub> <sup>2</sup>	--
Operator-perceived sound pressure level L <sub>pA</sub> (without cabin) <sup>3</sup>	-- dB(A)

1. According to ISO 6395 (EC Directives 2000/14/EC and 2005/88/EC)
2. According to EN ISO 4871 (EC Directives 2000/14/EC and 2005/88/EC)
3. According to ISO 6394 (EC Directives 84/532/EEC, 89/514/EEC, 95/27/EEC)



### Information

Measurements performed on asphalted surface.

## 9.12 Vibration

Vibration	
Effective acceleration value for the upper extremities of the body (hand-arm vibration)	< Trigger value < 2.5 m/s <sup>2</sup>
Effective acceleration value for the body (whole-body vibration)	< 0.5 m/s <sup>2</sup>

Vibration values indicated in m/s<sup>2</sup>.

Directive 2002/44/EC of European Parliament and Council on minimum health and safety requirements regarding exposure of workers to risks arising from physical agents (vibration).

### Indications on hand-arm vibration

Hand-arm vibration is less than 2.5 m/s<sup>2</sup> during correct machine operation.

### Indications on whole-body vibration

Whole-body vibration is less than 0.5 m/s<sup>2</sup> during correct machine operation.

Uncertainty of measurement K has been taken into account for the specified values.

The degree of vibration is influenced by various parameters.

Some of them are listed below:

- Operator: training, behavior, working method, and strain.
- Job site: organization, preparation, surroundings, weather conditions, and material.
- Machine: version, seat quality, quality of suspension system, attachments, and condition of attachments.

Precise indications on the vibration degrees cannot be made for the machine.

Determination of vibration level for the three vibration axes.

- Under typical operating conditions, use the average vibration values measured.
- In order to obtain the estimated vibration value for an experienced operator on level ground, subtract the factors from the average vibration value.
- In case of an aggressive working method or difficult terrain, add the environmental factors to the average vibration level in order to obtain the estimated vibration level.

**Note:**

For further vibration indications, refer to the indications in ISO/TR 25398 Mechanical Vibrations – Directive on Estimation of whole-body vibration during operation of earth moving machines. This publication uses measuring values of international institutes, organizations and manufacturers. It contains information on whole-body vibration for operators in earth moving machines. For more information on the vibration values of the machine, refer to Directive 2002/44/EC of European Parliament and Council on minimum health and safety requirements regarding exposure of workers to risks arising from physical agents (vibration).

It explains the values for vertical vibration under heavy operating conditions.



**Directives on reduction of vibration values in earth moving machines:**

- Perform correct adjustments and maintenance on the machine.
- Avoid jerky movements during machine operation.
- Keep slopes in a perfect condition.

Whole-body vibration can be reduced with the following guidelines:

- Use a machine and equipment of correct type and size.
- Follow the manufacturer's recommendations for maintenance.
  - Tire pressure.
  - Brake and steering systems.
  - Control elements, hydraulic system and linkage.
- Keep the job site in good condition:
  - Remove large rocks or obstacles.
  - Fill up ditches and holes.
  - Provide a machine and enough time to keep the job site in good condition.
- Use an operator seat according to the ISO 7096 requirements. Keep the operator seat in good condition and adjust it correctly:
  - Adjust the operator seat and suspension to the operator's weight and size.
  - Check and maintain the seat adjustment and suspension.
- Perform the following activities smoothly without any jerks.
  - Steering
  - Brakes
  - Acceleration
  - Shifting gears
- Move attachments without any jerks.
- Adapt your speed and the itinerary to minimize vibration:
  - Travel around obstacles and uneven ground.
  - Reduce your speed during machine travel across rough terrain.
- Reduce vibration to a minimum during long work cycles or during machine operation over long distances:
  - Use a machine with a suspension system (for example on the operator seat).
  - Enable the hydraulic oscillation damping if the machine is equipped with tracks.
  - If the machine is not equipped with hydraulic oscillation damping, reduce your speed to avoid bumps and jolts.
  - Load the machine on a truck or trailer to move between job sites.
- Other risk factors can affect drive comfort negatively. The following measures can improve drive comfort:
  - Adjust the operator seat and the control elements to a relaxed body posture.
  - Adjust the rearview mirrors to ensure optimal visibility so you can adopt an upright seating position.
  - Provide breaks to avoid sitting for long periods.
  - Do not jump off the cabin.
  - Picking up and raising loads repeatedly must be limited to a minimum.

**Reference:**

The vibration values and calculations are based on the indications made in ISO/TR 25398 Mechanical Vibrations – Guidelines for assessment of exposure to whole-body vibration during operation of earth moving machines.

The harmonized data comply with measurements made by international institutes, organizations and manufacturers. This publication offers information on the calculation of whole-body vibrations for operators of earth moving machines. This method is based on vibration measurements under real operating conditions for all machines. Read the original guidelines. This chapter summarizes part of the legal regulations. However, its aim is not to replace the original references. Other parts of this document are based on information of the United Kingdom Health and Safety Executive.

For more information on vibration, refer to Directive 2002/44/EC of European Parliament and Council on minimum health and safety requirements regarding exposure of workers to risks arising from physical agents (vibration).

Your Wacker Neuson dealer provides information on other machine functions reducing vibration and on safe operation.

## 9.13 Weight

### Machine weight

ET16 (canopy, standard travel gear, short shovel arm)	Weight kg (lbs)
Transport weight <sup>1</sup>	1402 (3,091)
Operating weight <sup>2</sup>	1529 (3,371)

1. Transport weight: basic machine + 10 % fuel capacity.

2. Operating weight: basic machine + full fuel tank + bucket (300 mm/12 in) + user (75 kg/165 lbs).



#### Information

Weight indications can vary by +/- 2 %.

### Determining the loading weight

The basis for calculating the loading weight is the shipping weight indicated on the machine nameplate. Add subsequently installed options and attachments (e.g. bucket, Easy Lock, breaker console) to the shipping weight. Add fuel depending on the tank capacity.

Option	Weight <sup>1</sup> kg (lbs)
Cabin	90 (198)
Telescopic travel gear	88 (194)
FOPS screen category II	53 (117)
FOPS screen category I	14 (31)
Quickhitch-ready	8 (18)
Long stick	8 (18)
Shatter protection	5 (11)
Attachments – see chapter “ <a href="#">Technical data of attachments</a> ” on <a href="#">page 9-15</a>	
Full fuel tank	20 (44)

1. The weight indications for options exclusively refer to Wacker Neuson original accessories.

### Application areas and application of attachments

---

#### **WARNING**

##### **Accident hazard due to unauthorized attachments!**

If unauthorized attachments are used, the machine can tip over, which can lead to serious injury or death.

- ▶ Only use attachments released by Wacker Neuson.
- 

#### **NOTICE**

Machine can be damaged due to unreleased attachments.

- ▶ Only use the attachments specified in the table.
- 

Compare the weight of the attachment and its maximum payload with the indications in the relevant lift capacity table or load diagram. Never exceed the maximum payload stated in the lift capacity table or load diagram.

---

#### **Information**

Please refer to the Operator's Manual and maintenance manual of the attachment manufacturer for operating and maintenance instructions for attachments such as hammers, grabs, hydraulic quickhitches, etc.

---

**Technical data of attachments**

<b>ET16 (without quickhitch system)</b>			
<b>Bucket type</b>	<b>Width mm (in)</b>	<b>Capacity m<sup>3</sup> (ft<sup>3</sup>)</b>	<b>Weight kg (lbs)</b>
Bucket	250 (10)	0.023 (0.8)	30 (66)
Bucket	300 (12)	0.028 (1.0)	32 (71)
Bucket	400 (16)	0.035 (1.2)	37 (82)
Bucket	500 (20)	0.044 (1.6)	43 (95)
Bucket	600 (24)	0.053 (1.9)	63 (139)
Ditch cleaning bucket	850 (33)	0,069 (2.4)	55 (121)
Ditch cleaning bucket	1000 (39)	0.082 (2.9)	66 (146)

<b>ET16 (Easy Lock system)</b>			
<b>Bucket type</b>	<b>Width mm (in)</b>	<b>Capacity m<sup>3</sup> (ft<sup>3</sup>)</b>	<b>Weight kg (lbs)</b>
Bucket	250 (10)	0.023 (0.8)	31 (68)
Bucket	300 (12)	0.028 (1.0)	34 (75)
Bucket	400 (16)	0.037 (1.3)	39 (86)
Bucket	500 (20)	0.046 (1.6)	47 (104)
Bucket	600 (24)	0.055 (1.9)	53 (117)
Ditch cleaning bucket	850 (33)	0.065 (2.3)	63 (139)
Ditch cleaning bucket	1000 (39)	0.078 (2.8)	72 (159)
Ditch cleaning bucket	1200 (47)	0.094 (3.3)	84 (185)

<b>ET16 accessories</b>	
	<b>Weight kg (lbs)</b>
Breaker console HS 02 (NE8/NE12)	14 (31)
Breaker NE8	88 (149)
Breaker NE12	110 (243)
Mechanical quick coupler system Lehnhoff MS01	18 (40)
Hydraulic Easy Lock quickhitch system (HS02)	19 (42)



### Excavator forces

According to ISO 6015

	<b>ET16</b>
Max. tearout force (short stick)	7.9 kN (1,776 lbf)
Max. breakout force at bucket tooth	15.3 kN (3,440 lbf)

## 9.14 Lift capacity/load

### Safety instructions lift capacity tables

Observe the values of the lift capacity tables in normal operation (for example excavating).

Observe the values of the load diagrams in lifting gear applications.

---

 **DANGER**

#### **Crushing hazard due to tipping over of machine!**

The machine causes serious injury or death when it tips over.

- ▶ The weight of the attachment and load must be subtracted from the weight specified in the corresponding column in the table.
- ▶ Pay attention to the density of the load.
- ▶ Do not exceed the weights indicated in the lift capacity tables.

---

#### **NOTICE**

If the weight is exceeded, there is a risk of damage to property if the machine tips over.

- ▶ Do not exceed the weights indicated in the load diagrams.

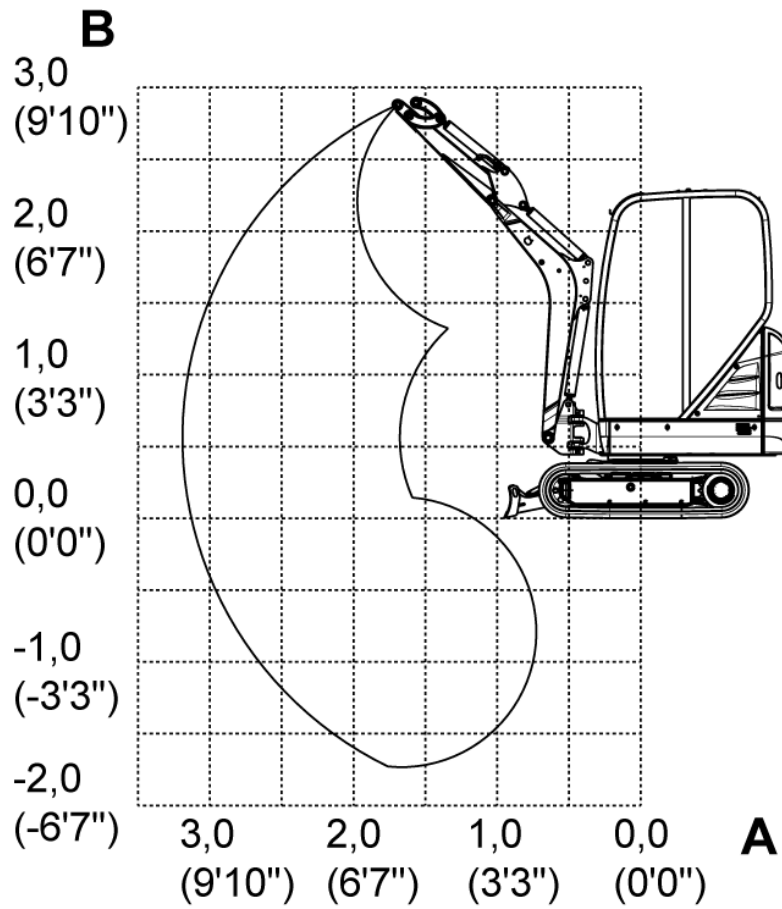
---

 **Information**

The indications are only approximate values. Uneven ground or poor ground conditions affect machine stability. The operator must take these influences into account.

---

Legend



Designation	Explanation
A	Reach from live ring center
B	Load hook height
max	Authorized lift capacity with horizontal boom



All table values are specified in kg (lbs), in horizontal position on firm and level ground without bucket or attachment (for example a breaker).

The machine's lift capacity is restricted by the settings of the pressure limiting valves, the hydraulic output and the hydraulic system's stabilizing features.

Neither 75 % of the static tilt load nor 87 % of the hydraulic lift capacity is exceeded.

Calculation basis: according to ISO 10567.

Setting pressure on boom cylinder: 20000 kPa (3,263 psi)

The lift capacity applies to machines under the following conditions:

- Fuel, lubricants and coolants at the prescribed levels
- Full fuel tank
- Machine at operating temperature
- Operator weight 75 kg (165 lbs)

### Lift capacity tables

#### Canopy/standard travel gear

A	max.			3.0 m (9' -10")			2.0 m (6' -7")		
B	Across stabilizer blade		Across side 360°	Across stabilizer blade		Across side 360°	Across stabilizer blade		Across side 360°
	Lowered	Raised		Lowered	Raised		Lowered	Raised	
1.5 m (4'-11")	395* (871*)	180 (397)	170 (375)	400* (882*)	180 (397)	175 (386)	430* (948*)	330 (728)	315 (694)
1.0 m (3'-3")	380* (838*)	165 (364)	155 (342)	405* (893*)	180 (397)	170 (375)	615* (1356)	315 (695)	300 (661)
0.5 m (1'-8")	365* (805*)	160 (353)	155 (342)	410* (904*)	175 (386)	165 (364)	725* (1598*)	295 (650)	280 (617)
0.0 m (0'-0")	350* (772*)	165 (364)	155 (342)	385* (849*)	170 (375)	165 (364)	715* (1576*)	285 (628)	270 (595)

#### Canopy/standard travel gear/long shovel arm

A	max.			3.0 m (9' -10")			2.0 m (6' -7")		
B	Across stabilizer blade		Across side 360°	Across stabilizer blade		Across side 360°	Across stabilizer blade		Across side 360°
	Lowered	Raised		Lowered	Raised		Lowered	Raised	
1.5 m (4'-11")	390* (860*)	170 (375)	160 (353)	415* (915*)	185 (408)	175 (386)	375* (827*)	355 (783)	335 (737)
1.0 m (3'-3")	375* (827*)	155 (342)	150 (330)	425* (937*)	175 (386)	170 (375)	575* (1268)	325 (717)	305 (672)
0.5 m (1'-8")	360* (794*)	150 (331)	145 (320)	410* (904*)	170 (375)	165 (364)	695* (1532*)	290 (639)	275 (606)
0.0 m (0'-0")	345* (761*)	155 (342)	145 (320)	400* (882*)	190 (419)	180 (397)	695* (1532*)	270 (595)	255 (562)

**Cabin/telescopic travel gear**

A	max.			3.0 m (9'-10")			2.0 m (6'-7")		
	Across stabilizer blade		Across side 360°	Across stabilizer blade		Across side 360°	Across stabilizer blade		Across side 360°
B	Lowered	Raised	Tele-scopic travel gear extended	Lowered	Raised	Tele-scopic travel gear extended	Lowered	Raised	Tele-scopic travel gear extended
	1.5 m (4' 11")	395* (871*)	215 (474)	295 (650)	400* (882*)	220 (485)	300 (661)	430* (948*)	390 (860)
1.0 m (3'-3")	380* (838*)	200 (441)	275 (606)	405* (893*)	215 (474)	295 (650)	615* (1356)	370 (816)	525 (1157)
0.5 m (1' 8")	365* (805*)	195 (430)	270 (595)	410* (904*)	210 (463)	290 (639)	725* (1598*)	355 (783)	505 (1113)
0.0 m (0'-0")	350* (772*)	195 (430)	275 (606)	385* (849*)	205 (451)	300 (661)	715* (1576*)	345 (761)	495 (1091)

**Cabin/telescopic travel gear/long shovel arm**

A	max.			3.0 m (9'-10")			2.0 m (6'-7")		
	Across stabilizer blade		Across side 360°	Across stabilizer blade		Across side 360°	Across stabilizer blade		Across side 360°
B	Lowered	Raised	Tele-scopic travel gear extended	Lowered	Raised	Tele-scopic travel gear extended	Lowered	Raised	Tele-scopic travel gear extended
	1.5 m (4' 11")	390* (860*)	205 (452)	280 (617)	415* (915*)	220 (485)	305 (672)	375* (827*)	375* (827*)
1.0 m (3'-3")	375* (827*)	190 (419)	265 (584)	425* (937*)	215 (474)	300 (661)	575* (1268)	385 (849)	540 (1191)
0.5 m (1' 8")	360* (794*)	185 (408)	255 (562)	410* (904*)	210 (463)	290 (639)	695* (1532*)	345 (761)	495 (1091)
0.0 m (0'-0")	345* (761*)	185 (408)	260 (573)	400* (882*)	225 (496)	315 (695)	695* (1532*)	325 (717)	470 (1036)

## Dimensions

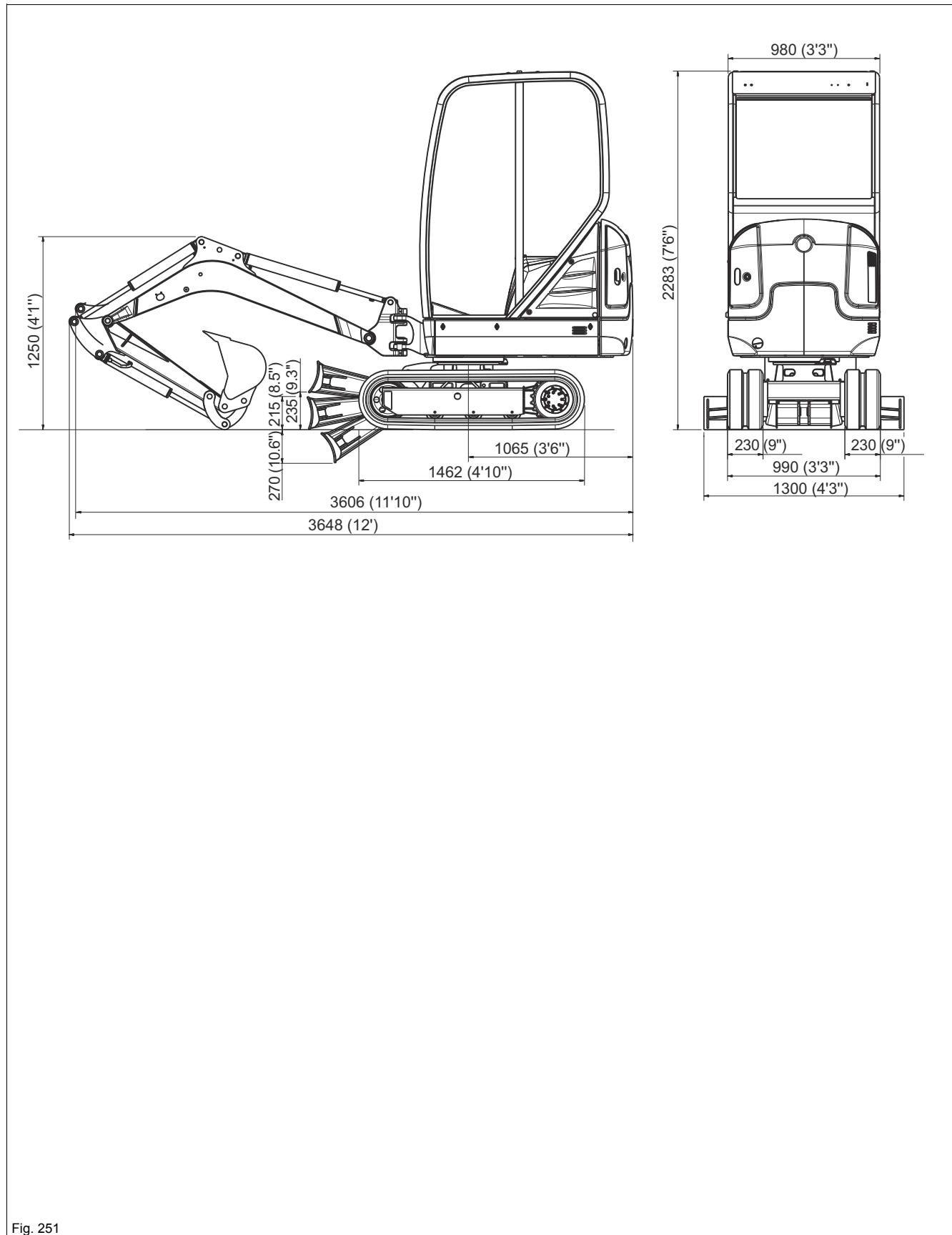


Fig. 251



<b>ET16</b>	
Height (standard travel gear)	2283 mm (89 in)
Height (telescopic travel gear)	2317 mm (91 in)
Upper carriage width	980 mm (39 in)
Width	990 mm (39 in)
Width with retracted telescopic travel gear	990 mm (39 in)
Width with extended telescopic travel gear	1300 mm (51 in)
Width with folded-in dozer blade	990 mm (39 in)
Width with folded-out dozer blade	1300 mm (51 in)
Transport length (short stick)	3645 mm (12')
Transport length (long stick)	3605 mm (11' -10")
Max. digging depth	2240 mm (88 in)
Length with short shovel arm	940 mm (37 in)
Length with long shovel arm	1100 mm (43 in)
Max. vertical digging depth	1640 mm (65 in)
Max. digging height	3390 mm (11' -2")
Max. tilt-out height	2370 mm (93 in)
Max. digging radius	3700 mm (12' -2")
Max. reach at ground level	3650 mm (12')
Min. tail end slewing radius	1075 mm (42 in)
Max. tail end lateral projection (90° rotation of upper carriage)	580 mm (23 in)
Max. boom displacement to bucket center (right side)	432 mm (17 in)
Max. boom displacement to bucket center (left side)	287 mm (11 in)



Notes:

## Index

### Numerisch

12 V socket ..... 5-10

### A

Abbreviations ..... 1-3  
 Adding coolant ..... 7-32  
 Adding engine oil ..... 7-30  
 Adding hydraulic oil ..... 7-39  
 Adjusting the mirrors (option) ..... 4-12  
 Air filter ..... 7-34  
 Air intake ..... 7-35  
 Arm rest ..... 4-14  
 Attachments ..... 5-41, 9-15  
     Picking up ..... 5-41  
     Setting down ..... 5-42  
 Axles ..... 7-42

### B

Ball bearing race ..... 7-11  
 Bleeding the fuel system ..... 7-28  
 Brake ..... 5-3, 9-3  
 Braking system ..... 7-42  
 Brief description of machine ..... 3-2  
 Bucket position when digging ..... 5-49  
 Bulbs ..... 9-6

### C

Cabin ..... 4-1  
 Changing the width of the stabilizer blade ..... 5-18  
 Charge indicator light ..... 4-28  
 Check lists ..... 4-31  
 Check the coolant level ..... 7-32  
 Check the hydraulic oil level ..... 7-38  
 Checking the engine-oil level ..... 7-30  
 Checking the hydraulic system for leaks ..... 7-40  
 Checking the water separator ..... 7-27  
 Checking track tension ..... 7-43  
 Cleaning and maintenance ..... 7-21  
 Cleaning the radiator ..... 7-33  
 Control lever base ..... 4-35  
 Conversion table ..... 1-7  
 Coolant compound table ..... 9-8  
 Coolant temperature ..... 4-29  
 Cooling system ..... 7-31  
 Correcting track tension ..... 7-44  
 Crane-lifting ..... 6-5

### D

Danger zone ..... 5-45  
 Designated use ..... 3-4  
 Determining the loading weight ..... 9-13  
 Diesel engine malfunctions ..... 8-1  
 Diesel fuel specification ..... 7-24  
 Differential lock ..... 5-8  
 Dimensions ..... 9-22  
 Dirt indicator ..... 7-34  
 Disassemble / assemble the canopy or cabin ..... 7-17  
 Display element ..... 4-26, 4-28  
 Disposal ..... 5-57

### E

Easy Lock ..... 5-30  
 EC Declaration of Conformity ..... EG-1  
 Electrical components ..... 9-4  
 Electrical system ..... 7-41  
 Emergency lowering ..... 5-52  
 Empty the water separator ..... 7-27  
 Engine lubrication system ..... 7-29  
 Engine oil pressure ..... 4-28  
 Engine oil types ..... 7-13  
 Engine start  
     Starting aid ..... 4-37  
 Entry and exit ..... 4-1  
 Excavator forces ..... 9-16  
 Exhaust gas treatment ..... 7-46  
 Explanation of symbols ..... 1-2  
 Extension and retraction ..... 5-19

### F

Fields of application of attachments ..... 9-14  
 Fire extinguisher ..... 4-14  
 Fluids and lubricants ..... 7-12  
 Foreword ..... 1-1  
 Fuel system ..... 7-24  
 Fuses and relays ..... 7-42

### G

Glossary ..... 1-4  
 Grading ..... 5-50  
 Ground clearance ..... 9-3  
 Ground pressure ..... 9-3

### H

Hammer operation ..... 5-22  
 Horn ..... 5-10  
 Hour meter/maintenance meter ..... 4-29  
 Hydraulic brake ..... 5-3  
 Hydraulic connections ..... 5-38  
 Hydraulic oil changing intervals for hammer operation

7-13		itch system .....	7-7
Hydraulic oil types .....	7-12	Malfunctions .....	8-1
Hydraulic quickhitch .....	5-30	Malfunctions of the hydraulic system .....	8-2
Picking up an attachment .....	5-31	Manual throttle .....	5-1
Setting down an attachment .....	5-35	Maximum speed .....	9-3
Hydraulic swivel unit brake .....	5-15	Mechanical brake .....	5-3
Hydraulic system .....	7-37	Mechanical quickhitch	
<b>I</b>		Picking up an attachment .....	5-26
Immobiliser .....	5-53	Setting down an attachment .....	5-28
Inadmissible work procedures .....	5-46	Models and trade names .....	3-2, 9-1
Increasing the width of the stabilizer blade .....	5-18	<b>N</b>	
Indicator lights and warning lights (overview) .....	4-28	Noise emissions .....	9-8
Information and regulations on use .....	3-4	<b>O</b>	
Information before putting into operation .....	4-30	Opening the engine cover .....	7-15
Information labels .....	3-13	Operation .....	5-1
Information on this Operator's Manual .....	1-1	Operation checklist .....	4-32
Information regarding operation with bio-hydraulic oil ..		Operation in water .....	5-48
7-13		Operation near the sea .....	5-48
Installing/removing the shatter protection .....	4-21	Operator seat .....	4-7
Introduction .....	3-1	Backrest adjustment .....	4-8
ISO/SAE control .....	5-15	Horizontal adjustment .....	4-8
<b>J</b>		Weight adjustment .....	4-7
Job site shatter protection .....	4-20, 5-23	Options .....	5-53
<b>L</b>		Overview of cabin operator's controls .....	4-24
Labels .....	3-5	Overview of control elements .....	4-23
Lehnhoff mechanical quickhitch system (optional) .....	5-25	<b>P</b>	
Letting the engine warm up .....	4-36	Parking checklist .....	4-32
Lift capacity table .....	9-17, 9-20	Parking the machine .....	5-8
Lifting gear applications .....	5-55	Parking the machine on slopes .....	5-8
Lights .....	5-9	Permanently putting out of operation .....	5-57
Loading .....	6-3	Power outlet .....	4-22
Loading material .....	5-50	Preheating .....	4-28
Loading the machine .....	6-3	Preparations for starting the engine .....	4-34
Loading vehicles .....	5-50	Preparatory work for putting into operation .....	4-30
Load-retaining function .....	5-39	Preparing lubrication .....	7-8
Locking the upper carriage .....	6-8	Proportional controls .....	5-52
Low-load operation .....	4-40	Protective FOPS structure .....	4-16
Lubrication .....	7-24	Protective structures .....	4-15
Lubrication plan .....	7-9	Putting back into operation .....	5-56
<b>M</b>		Putting into operation .....	4-1
Machine overview .....	3-1	Putting into operation for the first time and running-in	
Machine preservation .....	7-46	period .....	4-33
Machine travel .....	5-4	Putting out of operation temporarily .....	5-55
Machine travel and stopping .....	5-4	<b>R</b>	
Machine travel on slopes .....	5-5	Reducing the width of the stabilizer blade .....	5-18
Machine travel position .....	5-4	Reducing track tension .....	7-45
Machine weight .....	9-13	Re-equipping .....	5-43
Main fuse box .....	9-5	Refueling .....	7-25, 7-26
Maintenance (responsibilities and prerequisites) ...	7-1	Releasing pressure .....	5-43
Maintenance accesses .....	7-14	Releasing the pressure in the operating hydraulics .....	
Maintenance of attachments .....	7-46		
Maintenance of the electrical system .....	7-41		
Maintenance plan .....	7-4		
Maintenance schedule of Lehnhoff mechanical quickh-			



5-43	
Requirements for the operating personnel .....	4-30
Retracting seat belt .....	4-9
Revolving superstructure lock .....	6-8
Right/left/front/rear .....	1-5
Rotating beacon .....	5-10
Rotating the upper carriage .....	5-14
<b>S</b>	
Safe load indicator light .....	4-28
Serial number .....	3-6
Shatter protection .....	4-20
Shovel bucket operation .....	5-54
Speed control .....	5-4
Speed range selection .....	5-2
Starter .....	4-34
Starting and stopping the engine .....	4-34
Starts the engine .....	4-35
Start-up checklist .....	4-31
Steering system .....	5-1, 9-3
Stop the engine .....	4-40
Switches .....	4-26
Swiveling the boom .....	5-24
<b>T</b>	
Technical data .....	9-1
Engine .....	9-1
Tie-down points .....	6-3
Tightening the tracks .....	7-45
Tightening torques .....	9-7
Towing .....	6-1
Tracks .....	7-43, 9-3
Transportation .....	6-1
Transporting the machine .....	6-8
Travel signal .....	5-11
Traveling drive/axles .....	9-3
Travelling drive .....	7-42
Type label	
Canopy .....	3-8
Type labels .....	3-5, 3-6
FOPS screen .....	3-8
<b>U</b>	
Using attachments .....	9-14
<b>V</b>	
V-belt .....	7-36
Vibration .....	9-9
<b>W</b>	
Warning labels .....	3-9
Warranty and liability .....	1-8
Weight	
Attachments .....	9-15
Wiper/washer system .....	5-12
Work hydraulics .....	5-13, 9-3
Work operation .....	5-45
Work position of machine .....	5-49
Working alongside trenches .....	5-49, 5-50
Working lights .....	5-9
Working on slopes .....	5-51
Working with a hydraulic hammer .....	5-23
Working with a stabilizer blade .....	5-50



Wacker Neuson Linz GmbH keep abreast of the latest technical developments and constantly improve their products. For this reason, we may from time to time need to make changes to figures and descriptions in this documentation that do not reflect products that have already been delivered and that will not be implemented on these machines.

Technical data, dimensions and weights are only given as an indication. Responsibility for errors or omissions not accepted.

No reproduction or translation of this publication, in whole or part, without the written consent of Wacker Neuson Linz GmbH.

All rights under the provision of the Copyright Act are reserved.

Wacker Neuson Linz GmbH

Flughafenstr. 7

A-4063 Hörsching

Austria



**WACKER  
NEUSON**

**Wacker Neuson Linz GmbH**

Flughafenstr. 7  
A-4063 Hörsching

Phone: +43 (0) 7221 63000  
Fax: +43 (0) 7221 63000-2200  
E-mail: [office.linz@wackerneuson.com](mailto:office.linz@wackerneuson.com)  
[www.wackerneuson.com](http://www.wackerneuson.com)

Order no. 1000365220  
Language en